

07.1–111 Checking injection timing (begin of delivery) (position indicator RIV method)

Job no. of flat rates or standard texts and flat rates data 07–8240.

Testing and adjusting value

RI-test value (indirect injection timing) $-15^{\circ} \pm 1.5^{\circ}$ (after TDC)

RI-adjusting value (indirect injection timing) -15° (after TDC)

Tightening torque

Nm

Closing plug on regulator (measuring point)

30–35

Special tools

Position indicator

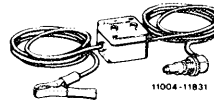

617 589 08 21 00

Drive square 1/2", 80 mm long
for rotating engine



617 589 00 16 00

Checking

- 1 Remove closing plug (2).

Attention!

When removing closing plug approx. 0.2 l engine oil will flow out. Collect oil.

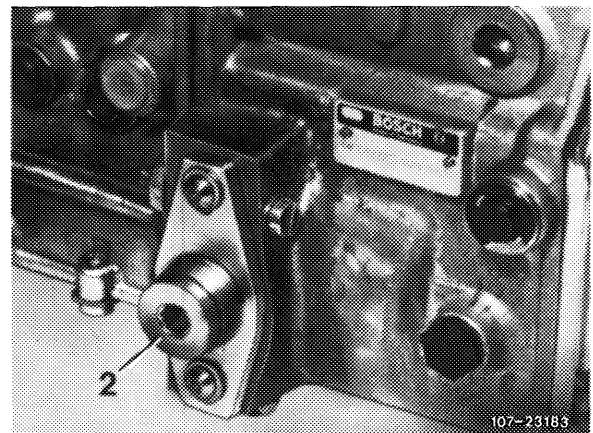

- 2 Slip position transmitter into regulator housing. Make sure that the guide pin of position indicator (arrow) is pointing upward. Tighten coupling nut manually.

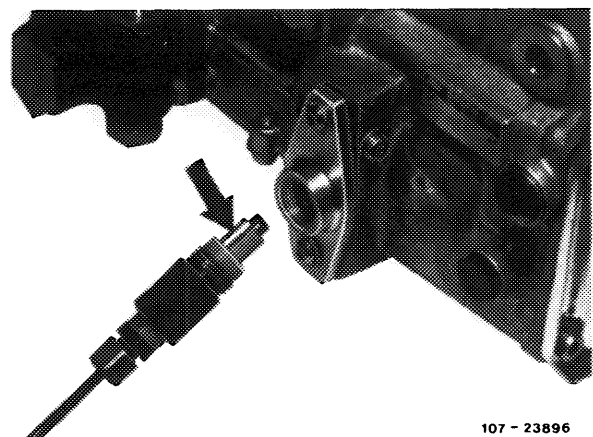

3 Connect indicating unit according to wiring diagram.

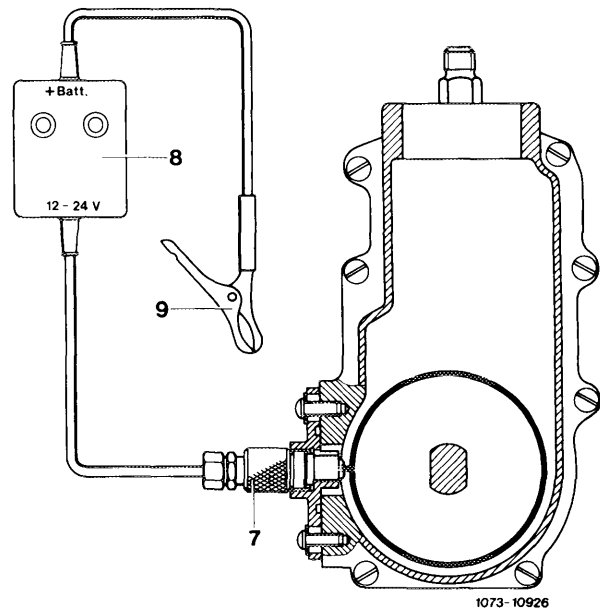

4 Rotate engine manually (in direction of rotation only) until lamp "A" lights up. Carefully continue rotating engine until **both lamps** are lighting up ("A and B"). In this position, read begin of delivery on graduated scale.

RI-value: -15° after TDC

If only lamp "B" lights up, repeat checkup.

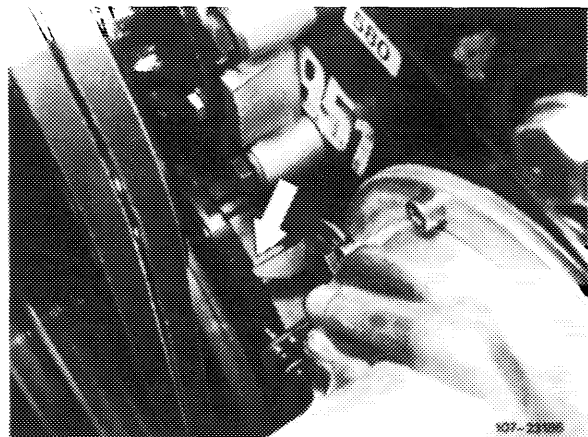

5 Remove position indicator, screw in closing plug.

6 Perform leak test with engine running. Check engine oil level or correct, if required.