

49–100 Removal and installation of exhaust system

Tightening torques	Nm	(kpm)
Self-locking nut on expansion pipe (model 107 only)	20–25	(2–2.5)
Self-locking nut on exhaust manifold to exhaust flange	20–25	(2–2.5)

Removal and installation of exhaust system is not fully explained, only a few particularly important items are described which must be observed during removal and installation or during partial renewal e.g. of resonance damper with plug connection.

Removal

- 1 If the plug connection cannot be separated, heat exhaust pipe. For safety reasons and prior to heating the pipes, place a protective panel on vehicle between frame floor and exhaust pipes.
- 2 Check fastening members for re-use and replace, if required.

Installation

Replacement of resonance damper.

- 3 Place new resonance damper with plug connection accurately on removed installation (standard system) and mark pipe length of new resonance damper on removed unit.

Cut pipe 80 mm minus 10 mm from mark in direction of resonance damper to guarantee a plug-in depth of 70–80 mm.

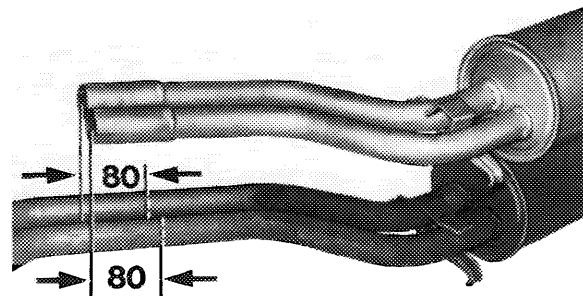

4 Always replace self-locking hex nuts and sealing rings.

5 Exhaust pipe manifold connection.

Tighten flange connection to exhaust manifold not before the complete system is mounted in rubber rings. Tightening torque of hex bolts 20–25 Nm (2–2.5 kpm).

- | | |
|--|------------------------|
| 1 Exhaust manifold | 4 Sealing ring |
| 2 Exhaust pipe with trapezoidal connection | 6 Self-locking hex nut |
| 3 Flange | 7 Hex bolt |

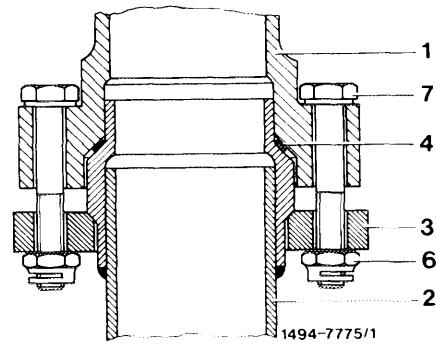

6 Pay attention to distance between center resonance damper and frame floor (distance approx. 20 mm, model 116 only, arrows).

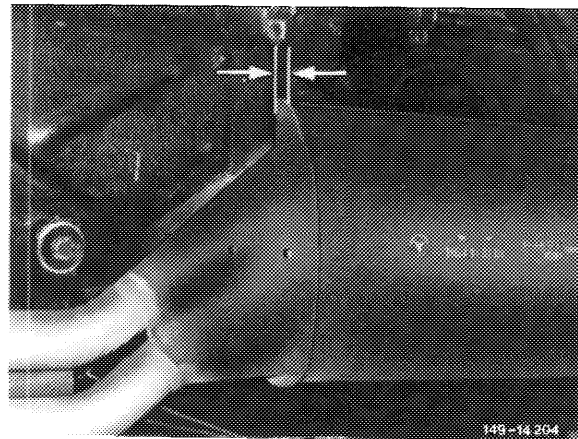

Note: The rubber rings are available in two different degrees of shore hardness. Hardness is identified by compression test.

7 On model 116 use only the softer rubber rings at front exhaust suspension.

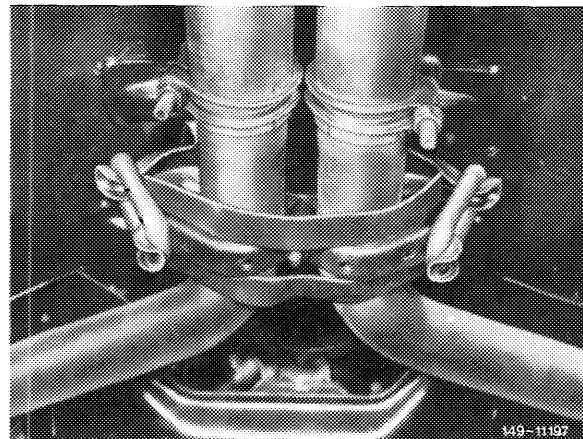

8 Tighten flange connection (2) on expansion pipe only after the complete exhaust system has been mounted. Then tighten pipe clip (3). Tightening torque of self-locking nuts 20–25 Nm (2–2.5 kpm) (model 107 only).

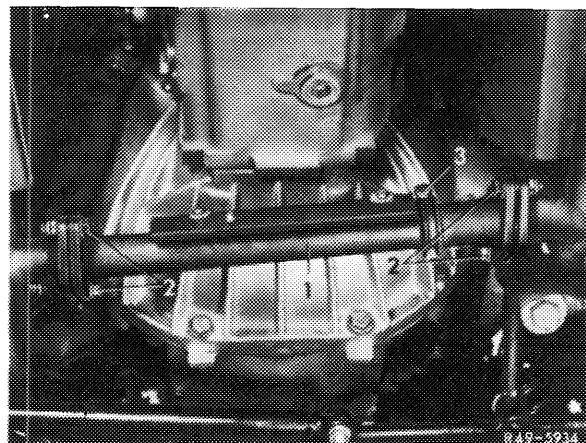

9 Mount resonance damper in such a manner that the holders of the resonance damper are **approx. 10 mm** in front of holders on frame floor (arrows), so that the correct installation position is assured when exhaust system is subject to elongation.

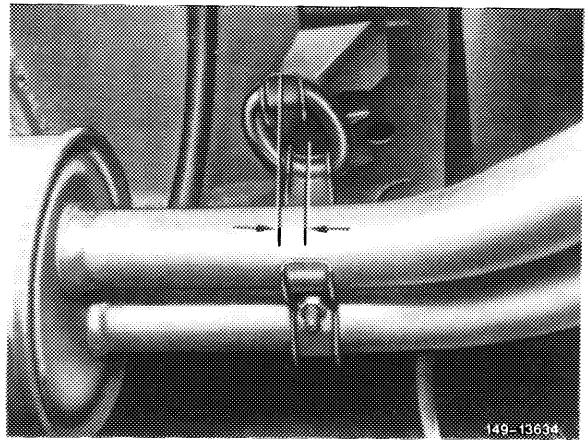

10 Run engine and check exhaust system for leaks.

Exhaust manifold with complete exhaust system
Models 107.023/024/043/044

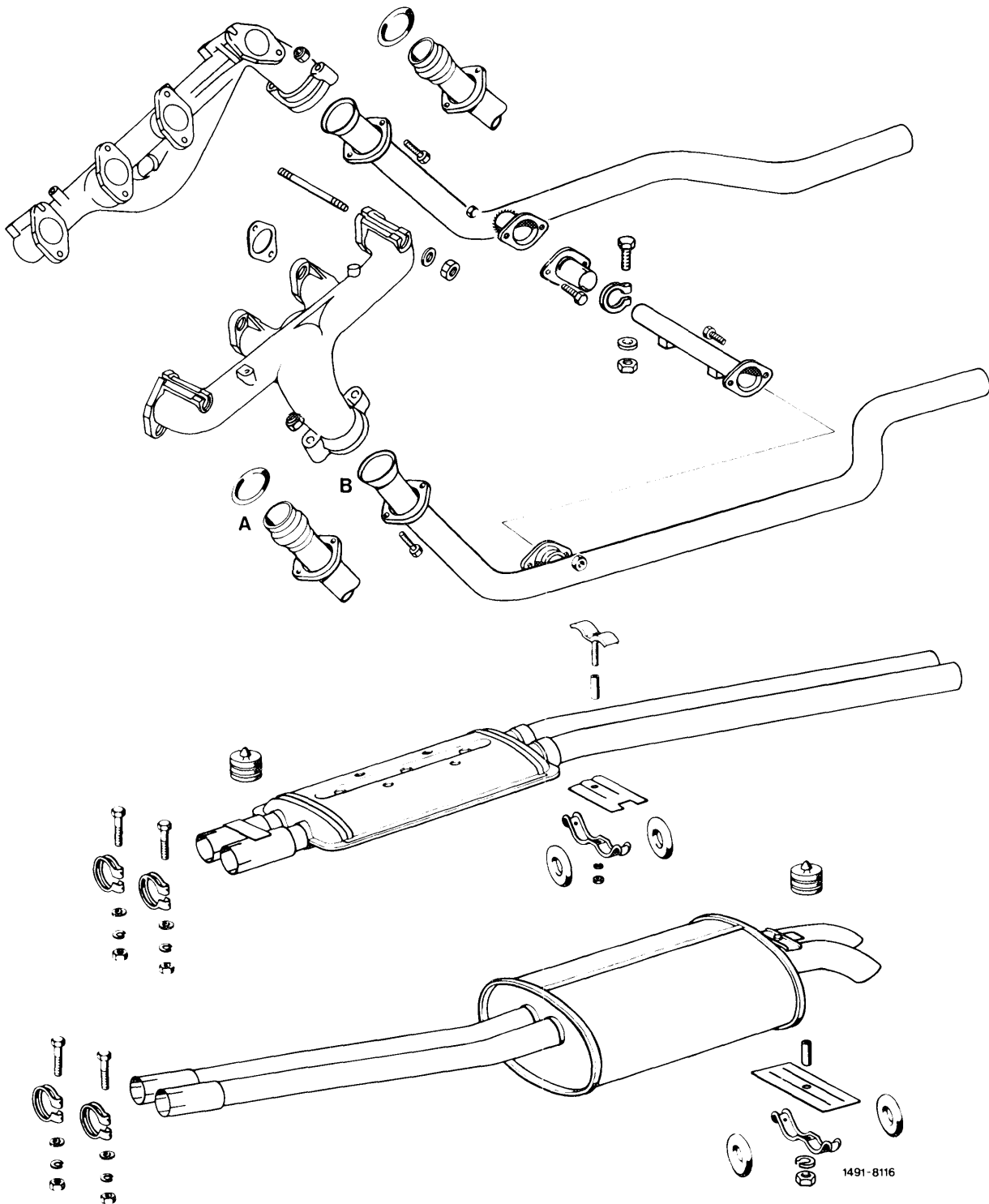

- A Front exhaust pipe with trapezoidal connection (on vehicles with electronic gasoline injection and CIS 1st version)
- B Front exhaust pipe with flare for ball connection (on vehicles with CIS 2nd version).

Exhaust manifold with complete exhaust system
Models 116.028/029/032 /033

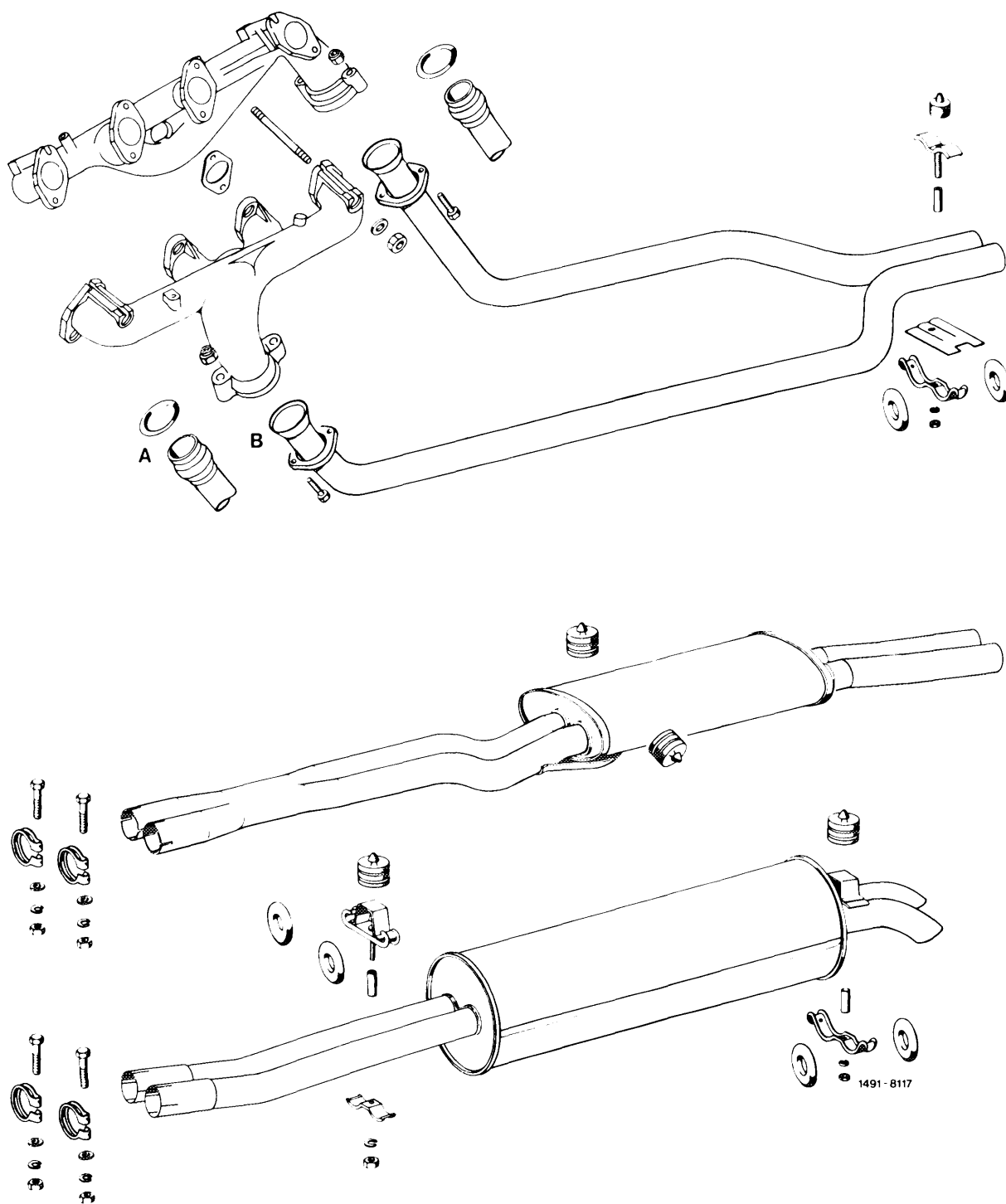

- A Front exhaust pipe with trapezoidal connection (on vehicles with electronic gasoline injection and CIS 1st version).
- B Front exhaust pipe with flare for ball connection (on vehicles with CIS 2nd version).