

Fuel pump assembly with steel line between fuel pump and filter

- 1 Unscrew protective box.

- 2 Pinch fuel hoses (from fuel tank and line to engine) with one clamp each.

- 3 Unscrew fuel pump assembly on both front vibration dampers.

- 6 Holder for fuel pump and filter
- 12 Leak line
- 14 Pressure reservoir
- 15 Holder for pressure reservoir
- 19 Fuel hose
- 21 Filter
- 22 Fuel pump
- 24 Suction damper
- 26 Fuel pressure line
- 27 Pressure compensating valve
- 28 Clamp for pressure compensating valve
- 29 Closing cone
- 30 Coupling nut
- 31 Closing nut
- 32 Check valve
- 33 Sealing ring

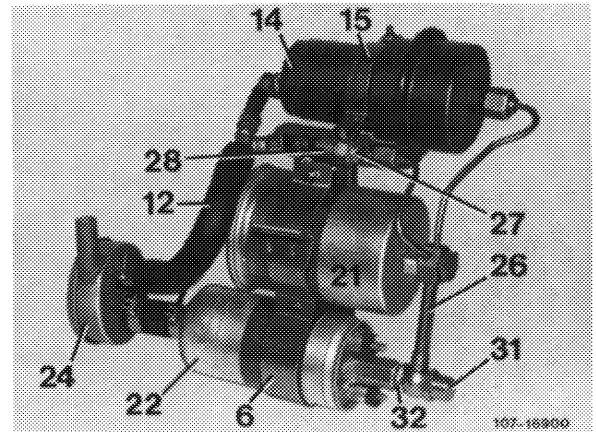
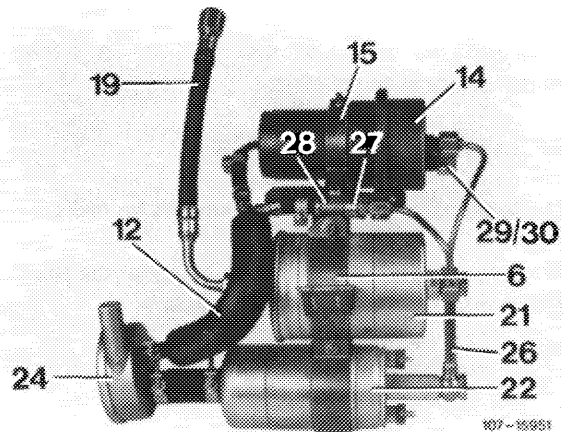

- 4 Unscrew steel line (26) on fuel pump, filter, reservoir and pressure compensating valve.

- 5 Screw check valve (32) with new copper sealing ring (33) to fuel pump.

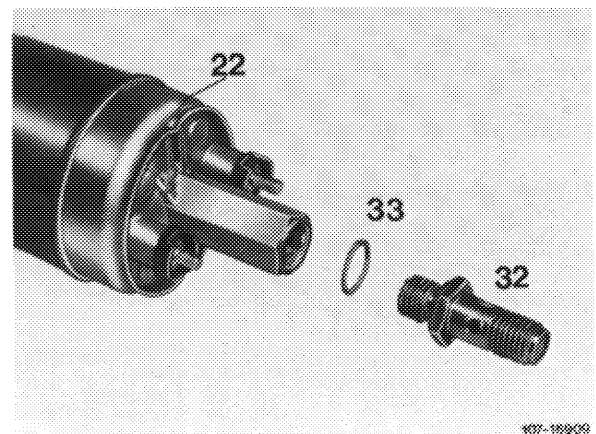

6 Mount steel lines. For this purpose, slip fuel pump up to bead into holder. Connect steel line with new copper sealing rings and closing nut (screw on closing rings and closing nut lightly only). Hollow screw is no longer installed.

Note: Plastic film or plastic sleeve of pump and filter should project on holder on both sides and must be renewed, if damaged. For this purpose, remove pump and filter.

7 Mount fuel filter in holder in such a manner that the steel line is in alignment with fuel pump.

8 Mount steel line on reservoir and pressure compensating valve and tighten connections (apply counterhold to check valve).

9 Tighten fuel pump and filter in holder and screw holder to vibration dampers.

10 Remove clamps on fuel hoses.

11 Run engine and check connections for leaks.

12 Mount protective box. Make sure that the steel line is not chafing against protective box.

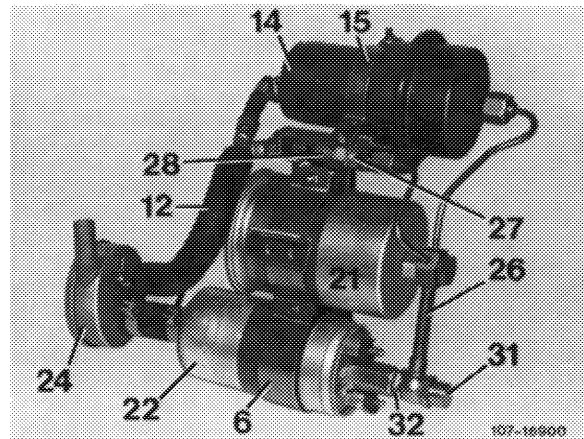
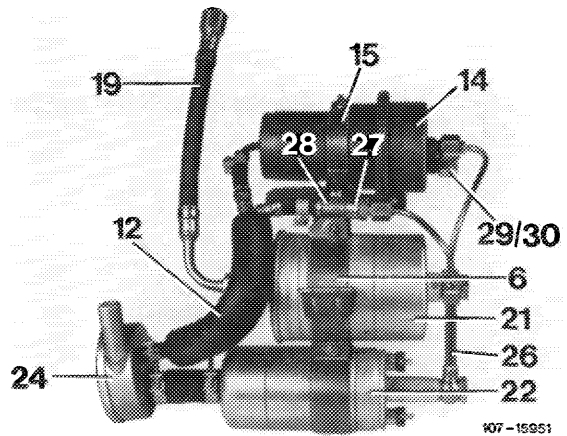

Fuel pump assembly with hose between pump and filter

- 1 Unscrew protective box.
- 2 Pinch fuel hoses with clamps.

- 14 Pressure reservoir
- 21 Filter
- 22 Fuel pump
- 24 Suction damper

