

**05–213 Inspection and correction of basic position of hydraulic valve clearance compensating elements**

**Thickness of thrust piece "S" in mm**

**Part No.**

6.15  
5.8  
5.45  
5.1  
4.75  
4.4  
4.05  
3.7

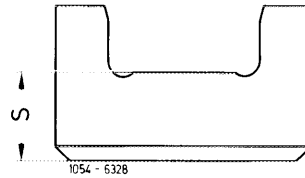

117 053 07 53  
117 053 06 53  
117 053 05 53  
117 053 04 53  
117 053 03 53  
117 053 02 53  
117 053 01 53  
117 053 00 53

**Tightening torque**

**Nm**

Nuts for cylinder head cover

3

**Special tools**

Test gauge for hydraulic compensating elements



117 589 06 23 00

Valve spring depressor

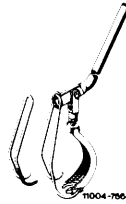

123 589 03 61 00

**Note**

The test gauge serves to determine the basic position or a plus deviation (+) or minus deviation (–) of hydraulic element.

In the event of a plus deviation (+) or a minus deviation (–), the installation of a thinner or thicker thrust piece (4) will regain the basic position.

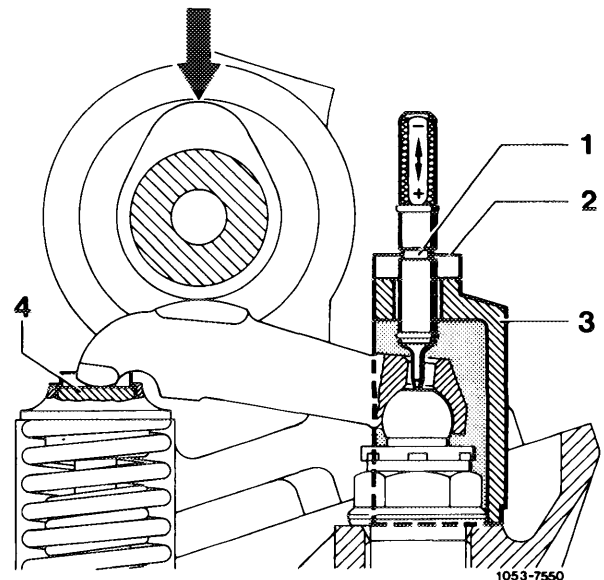

## Checkup

---

1 When a new compensating element is installed, rotate engine with starting motor for approx. 30 seconds prior to checkup.

2 Rotate engine:

### Model 107

On 4-pole cable connector disconnect cable terminal 16 (cable color red/purple), so that the ignition coil and the fuel pump are not activated. Connect terminal 30 (cable color red) and terminal 50 (cable color purple).

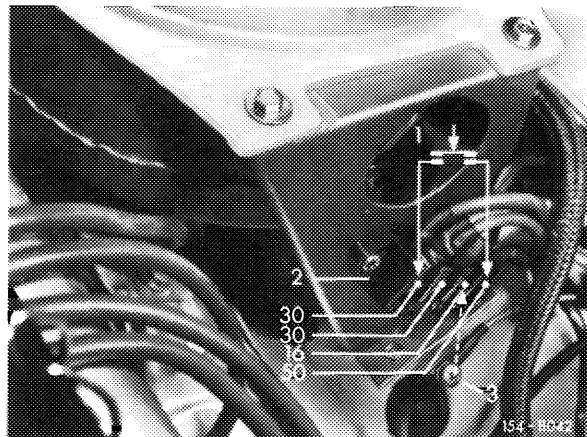

### Model 116

Switch off ignition. Pull out fuel pump relay code No. 21 in fuse box. Connect contact handle to battery + and with the assistance of a pin to contact bushing 1 of coupling (arrow).

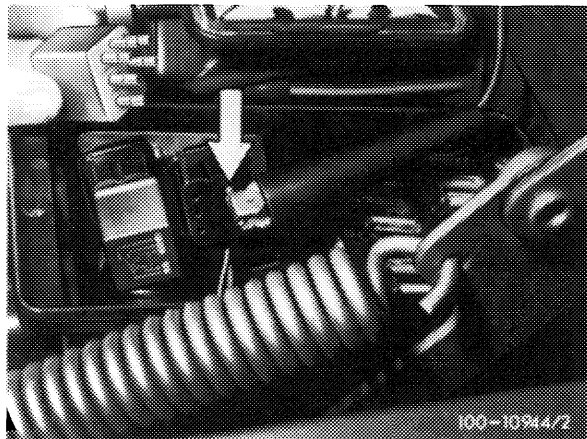

3 Take load from hydraulic element to be checked, that is, the cam tip should point in upward direction (arrow).

4 Place test gauge over hydraulic element to be tested and set measuring pin on ball pin.

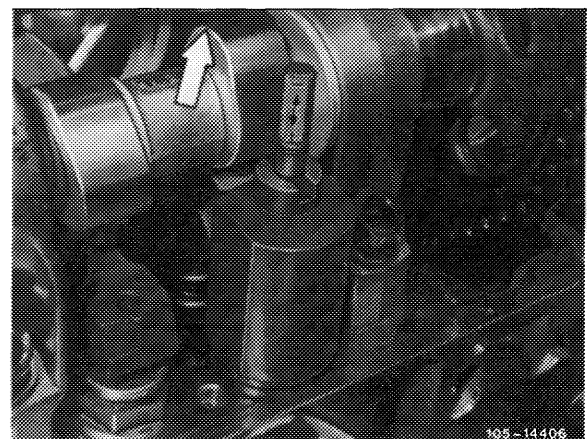

5 Check position of measuring groove (1) in relation to measuring gauge (2):

a) The basic position is correct when the measuring edge (2) is within the 1.2 mm wide, red measuring groove (1).

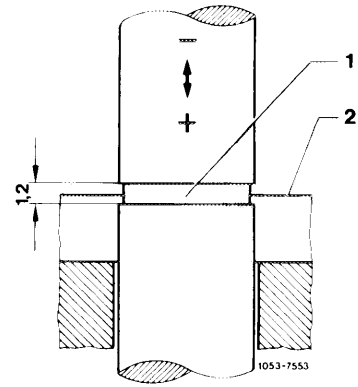

b) Plus deviation (+) is indicated when the measuring edge (2) is above the red measuring groove (1).

**Remedy:** In the event of a plus deviation (+), install thinner thrust piece.

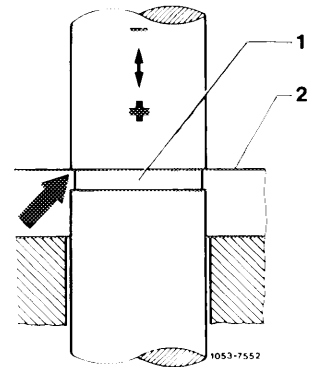

c) Minus deviation (-) is indicated when the measuring edge (2) is below the red measuring groove (1).

**Remedy:** In the event of a minus deviation (-), install thicker thrust piece.

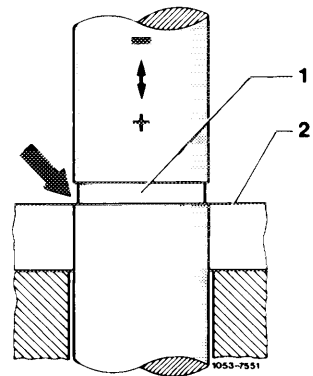

### Correction

6 Remove rocker arm with lever-type pusher, remove thrust piece.

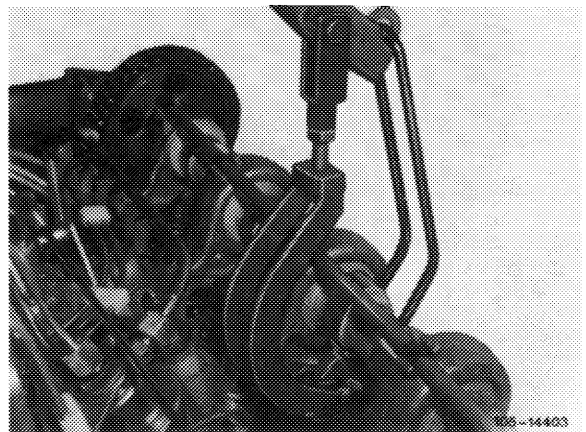

7 Measure thickness of thrust piece "S".

---

Thickness of thrust piece "S" in mm	Part No.
6.15	117 053 07 53
5.8	117 053 06 53
5.45	117 053 05 53
5.1	117 053 04 53
4.75	117 053 03 53
4.4	117 053 02 53
4.05	117 053 01 53
3.7	117 053 00 53

---

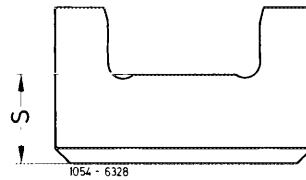

8 In the event of a plus deviation (+), install thinner thrust piece, in the event of a minus deviation (-), install thicker thrust piece.

**Note:** During new adjustment, try for center position on measuring groove.

9 Install rocker arm and repeat checkup.