

1 Make test line harness yourself with the following parts:

1 Coupling, comprising:

- 1 body 008 545 08 28
- 1 cover 008 545 11 28
- 2 bushings 001 545 26 26

2 Plugs, comprising:

- 1 body 008 545 09 28
- 1 cover 008 545 11 28
- 2 pins 008 545 18 28

3 Line brown/black 1.0 mm²

4 Line brown/black 1.0 mm² (3 m long)

5 Line black 1.0 mm²

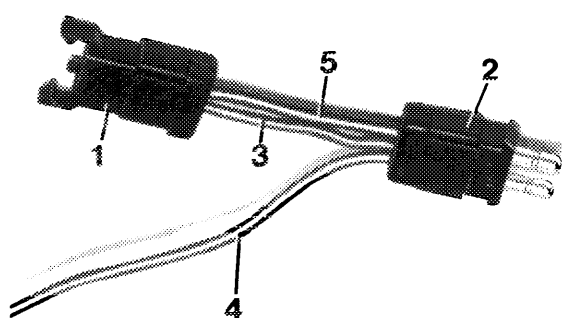

154-11980

2 Install test line harness (6) between actuator and line harness (2).

3 Connect voltmeter, while clamping + connection to test line (4) and – connection to seat rail.

4 Switch on ignition and check stop light for function.

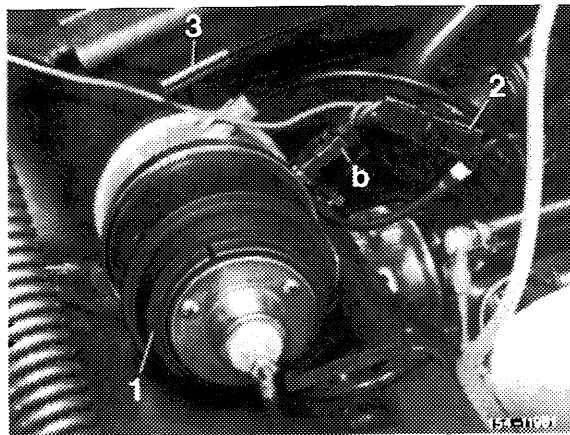

5 Actuate switch, brake and ignition key as follows:

Position	Nominal value
Off	0 V
Accelerate	> 11 V
Actuate brake pedal	0 V
Memory	> 11 V
Ignition off/on	0 V
Decelerate	> 11 V
Actuate clutch pedal	0 V

6 With negative indication, check connection of line harness on stop light switch (refer to wiring diagramm 54–580). If connection is correct, check switch. If switch is in order, connect new control unit on trial.

