

46–550 Removal and installation of drag link

Data

Model	Part No. 1st version	2nd version	Length "a"
116.020 116.032/033 116.120	116 460 06 05	116 460 09 05	477 ± 0.5
116.036	116 460 07 05	116 460 10 05	515 ± 0.5

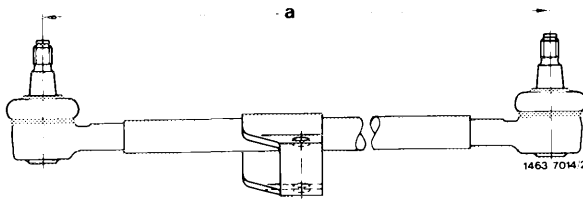

Approved grease types for ball joints

Multi-purpose grease

refer to Specifications for service products page 267

Tightening torques

Nm

Castle nut for attaching drag link to steering arms

35

Hex screw for attaching steering shock absorber to drag link

45

Special tool

Puller for drag link



123 589 09 33 00

Self-made tools

Assembly sleeve for flat-wire clamping ring

refer to fig. item 11

Assembly sleeve for plastic ring

refer to fig. item 11

Removal

1 Uncotter castle nuts (34) on joints of drag link (11) and unscrew.

2 Unscrew hex. screw for attaching shock absorber and force steering shock absorber out of mounting.

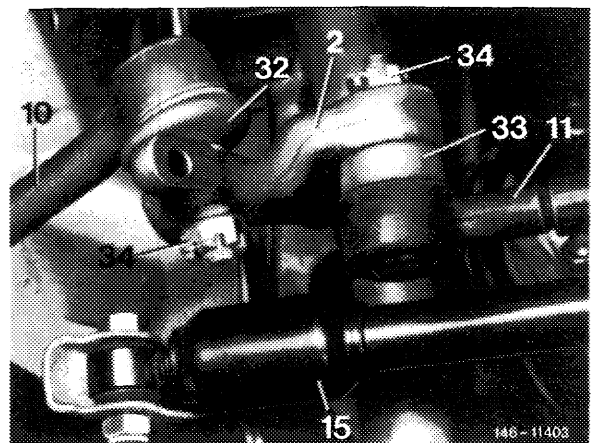

3 Force drag link (11) from steering arms with puller (066).

Note: To prevent damage to rubber sleeve of drag link 2nd version, push drag link off only with modified puller 123 589 09 33 00.

Puller 123 589 00 33 00 may be used only if the puller bell has been refinished as required.

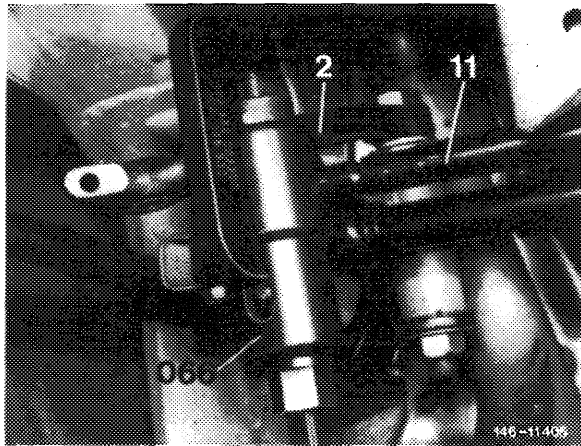

4 On drag link 1st version, remove plastic cover (33) and sealing ring (35).

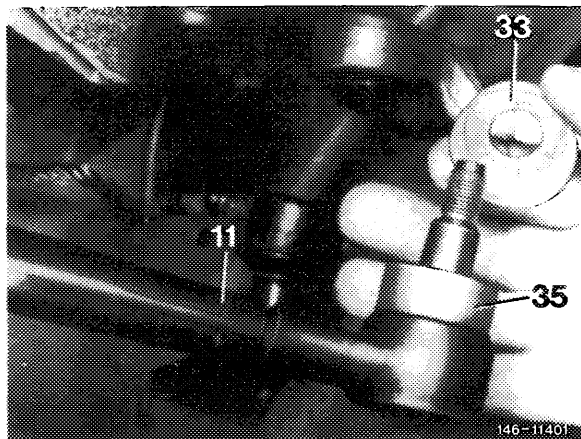

Checking

1st version

5 Check joints (1) of drag link. If joints are moving too easily or are subject to play, replace drag link.

- 1 Ball pin
- 2 Plastic cover
- 3 Sealing ring
- 4 Plastic bearing shell
- 5 Head of joint
- 6 Compression spring
- 7 Pressure plate
- 8 Closing cover

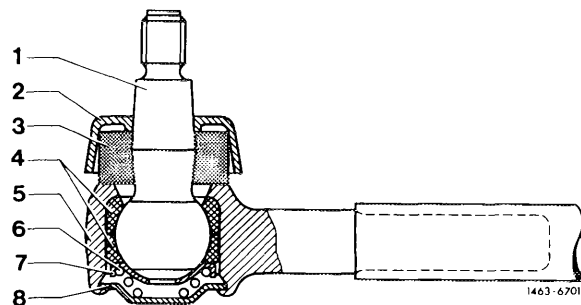

2nd version

6 Check joint of drag link. If joints are moving too easily or are subject to play, replace drag link.

7 Check rubber sleeves (2) for joints.

If a rubber sleeve on used joint is damaged, replace drag link.

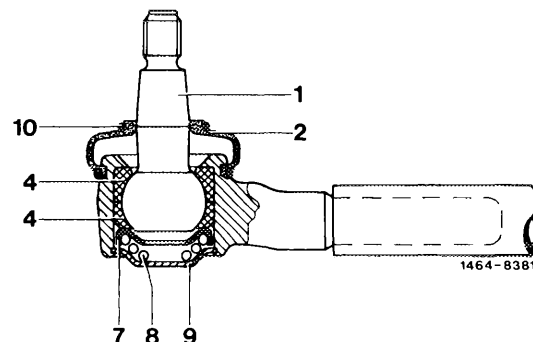

8 If the rubber sleeve (2) has been damaged during removal of drag link, replace rubber sleeve only. For this purpose, remove flat-wire clamping ring (3) and pull off sleeve including plastic fastening ring (10).

9 Prior to mounting new rubber sleeve, fill space between sleeve and joint with specified grease.

10 Mount rubber sleeve (2) and then assembly sleeve (20) on ball pin. Insert plastic fastening ring (10) over assembly sleeve into rubber sleeve.

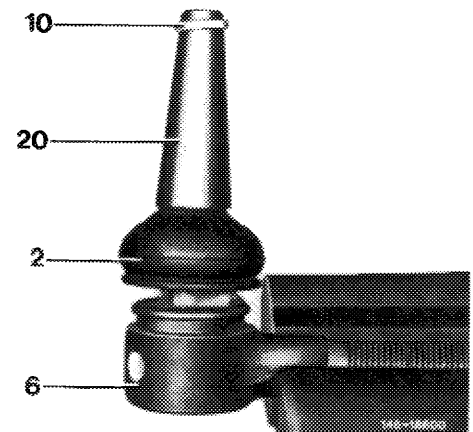

11 Place assembly sleeve (21) on ball joint and over rubber sleeve (2), insert flat-wire clamping ring (3).

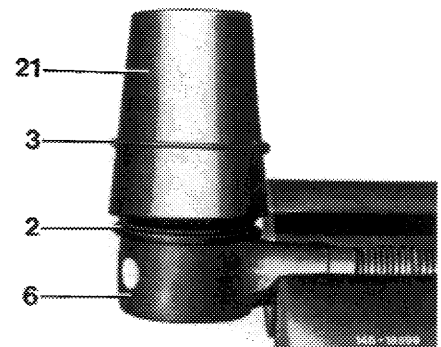

Note: Assembly sleeves are self-made according to specified dimensions.

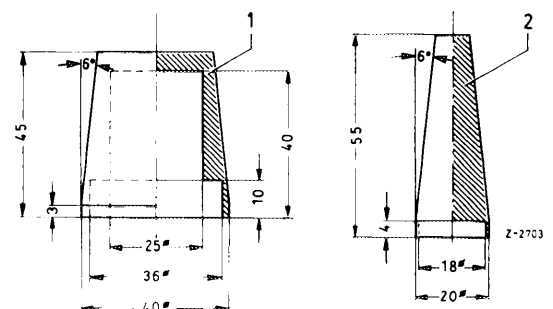

- 1 Assembly sleeve for flat-wire clamping ring
- 2 Assembly sleeve for plastic ring

Note: The maintenance-free joints are provided with grease for life. On these joints, the **sealing** against the penetration of dirt for life of joint is of **decisive significance**. A damaged rubber sleeve should therefore be replaced **immediately**, since otherwise the penetrating dirt will wear-out the joints. For this reason, it is also necessary to check joints carefully **at regular intervals**.

Installation

12 On 1st version of drag link, replace sealing ring (35) and plastic cover (33).

Drag link 1st version

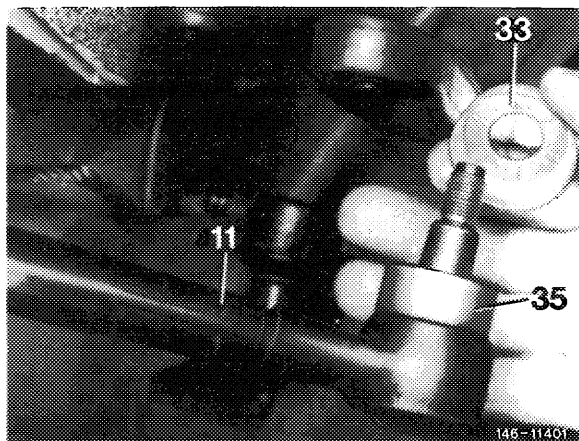

Drag link 2nd version with rubber sleeve

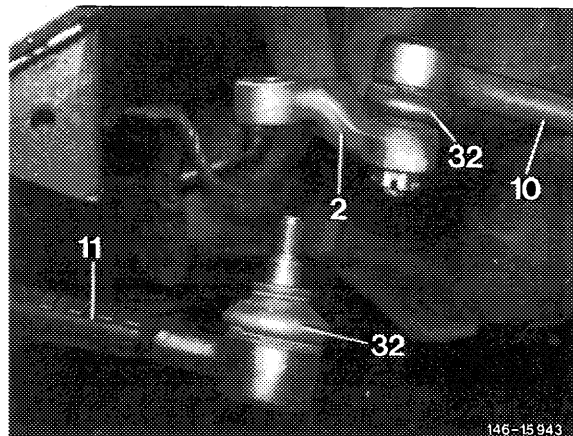

13 Clean ball pin as well as conical seats in steering arms perfectly from grease. Push ball pin **tightly** into cone of steering arms. Screw-on castle nuts and cotter. Tightening torque 35 Nm – reference value.

14 Attach steering shock absorber to drag link.

15 Check wheel adjustment on front axle (40–320).

Drag link 1st version

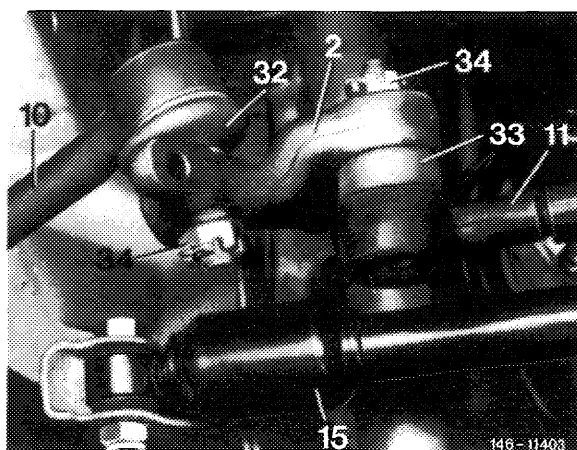

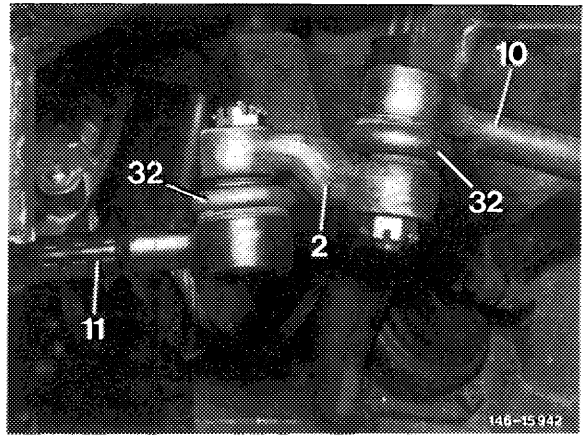

Drag link 2nd version