

46–540 Removal and installation of track rod

Data

Model	Part No.	Length "a"	Remarks
116.020 116.032/033 116.120	116 330 02 03	367 ± 2	Lefthand threads mounted at left in driving direction (painted grey-green)
116.036	123 330 07 03	345 ± 2	Long ball housing journal mounted to pitman arm or intermediate steering arm (painted black)

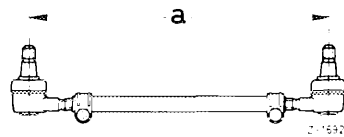

Approved grease types for ball joints

Multi-purpose grease	refer to Specifications for service products page 267
----------------------	---

Tightening torques

Nm

Castle nut for attaching track rod to steering arms

35

Hex. screw to clamp of track rod

20

Special tools

Puller for ball joint of track rod



186 589 10 33 00

Self-made tools

Assembly sleeve for flat-wire clamping ring

refer to illustration item 8

Assembly sleeve for plastic ring

refer to illustration item 8

Removal

1 Uncotter castle nut (34) on joints of track rod and unscrew.

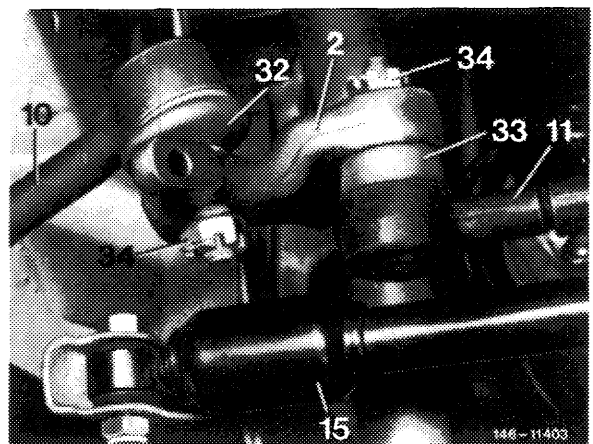

2 Force track rod from steering arm with puller (065).

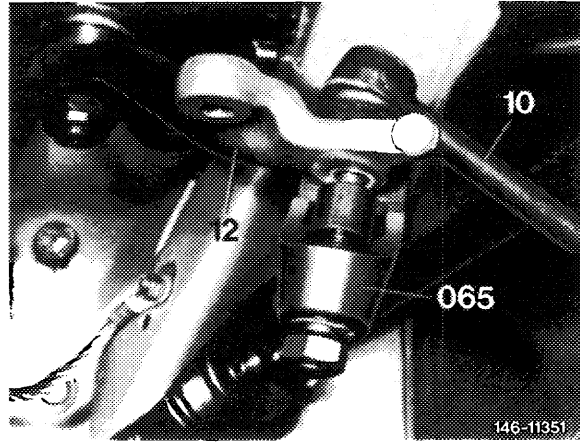

Checkup

3 Check joints of track rod. If track rods are moving too easily or are subject to play, replace respective track rod head.

4 Check rubber sleeves (2) for joints. **If a used joint has a damaged rubber sleeve, completely replace respective joint.**

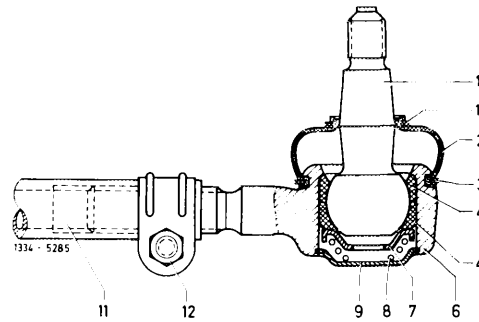

5 If the rubber sleeve (2) has been damaged when removing track rod, replacement of rubber sleeve will be enough. For this purpose, remove flat-wire clamping ring (3) and pull off sleeve including plastic fastening ring (10).

6 Prior to mounting new rubber sleeve, fill space between sleeve and joint with specified grease.

7 Mount rubber sleeve (2) and then assembly sleeve (20) on ball pin. Insert plastic fastening ring (10) over assembly sleeve into rubber sleeve.

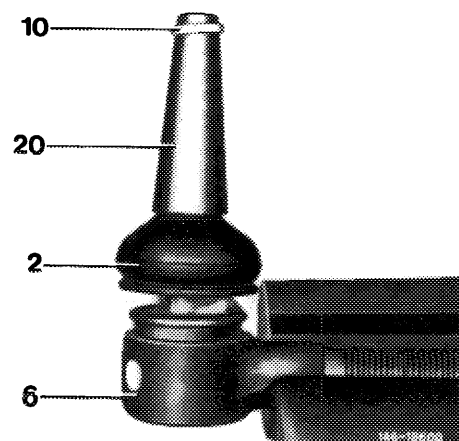

- 8 Place assembly sleeve (21) on ball joint and over rubber sleeve (2) and insert flat-wire clamping ring (3).

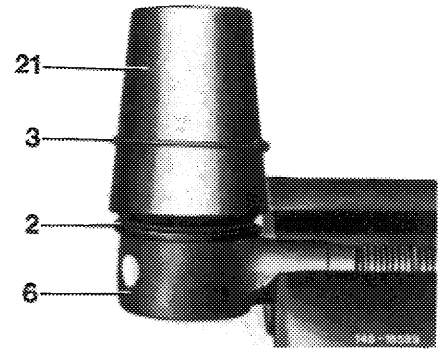

Note: Assembly sleeves are self-made according to specified dimensions.

- 1 Assembly sleeve for flat-wire clamping ring
2 Assembly sleeve for plastic ring

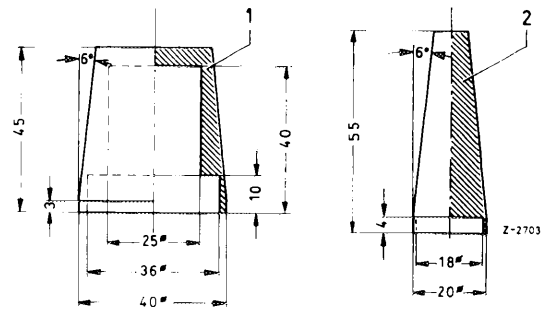

Note: Maintenance-free joints are provided with grease for life. On these joints, the seal which prevents the entry of dirt is of decisive importance for the life of the joint. A damaged rubber sleeve should therefore be immediately replaced, since otherwise the penetrating dirt may result in wear of joint. For this reason, make sure that the joints are carefully checked at regular intervals.

Installation

- 9 Clean ball pins as well as conical seats in steering arms perfectly from grease. Then push ball pin tightly into cone of steering arm. **Screw-on castle nut** and tighten. Tightening torque 35 Nm — reference value. Cotter castle nut.

Note: On model 116.036 make sure that ball joint is attached to pitman arm or intermediate steering arm with the longer threaded journal.

- 10 Check wheel adjustment on front axle (40–320).

