

## 46-510 Removal and installation of pitman arm



### Data

Model	Part No.	Version	Code No.
116.02	116 463 1001	Lefthand steering	1610
116.032/033			
116.120	116 463 1101	Righthand steering	1611
116.036	116 463 1201	Lefthand steering	1612
	116 463 1301	Righthand steering	1613

### Tightening torques

	Nm
Self-locking hex. nut to pitman shaft	160-200
Castle nut to track rod and drag link	35

### Special tools

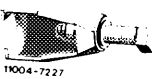
Puller for ball joint of track rod		186 589 10 33 00
Puller for ball joint of drag link		123 589 09 33 00
Puller for pitman arm		100 589 04 33 00

### Self-made tool

Sleeve	refer to illustration item 10
--------	-------------------------------

### Removal

- 1 Uncotter castle nut of drag link and track rod on pitman arm and unscrew castle nut.

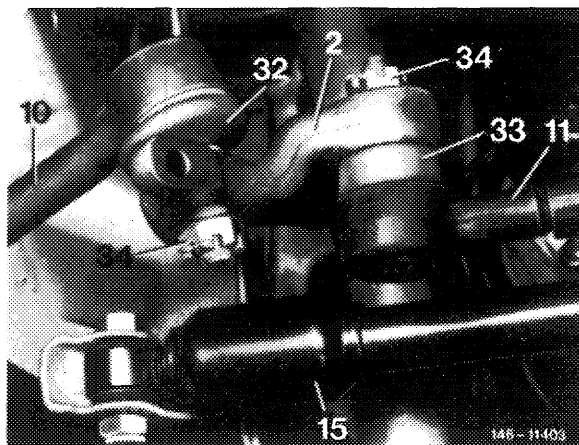

2 Force ball joint of track rod (10) from pitman arm by means of puller (065).

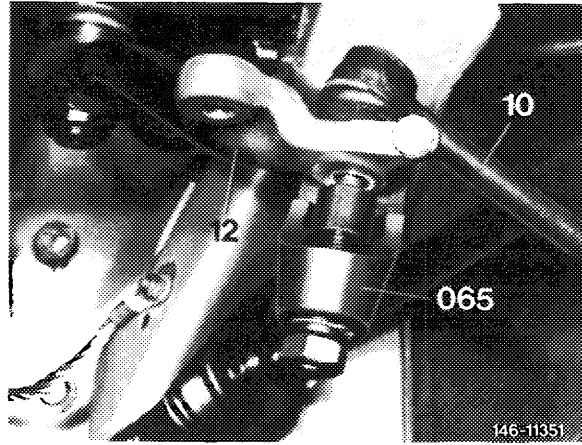

3 Force ball joint of drag link (11) from pitman arm by means of puller (066). On 1st version of drag link, pay attention to plastic cover ring and sealing washer.

**Note:** To prevent any damage to rubber sleeve with drag link 2nd version, force drag link off only with modified puller 123 589 09 33 00.

Puller 123 589 00 33 00 may be used only if the puller bell has been refinished as required.

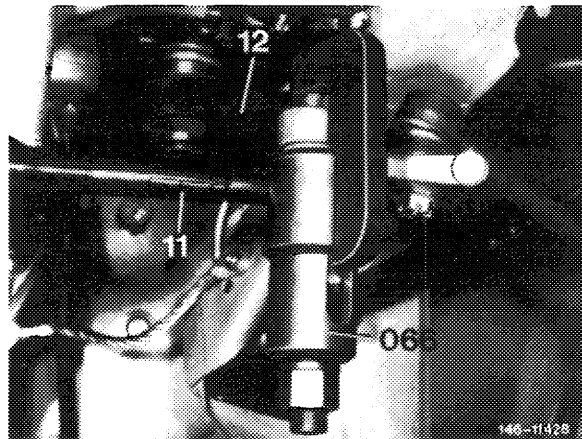

4 Unscrew self-locking hex. nut (3) from pitman shaft and remove protective cap (28).

**Note:** The protective cap is installed on vehicles with V-8 engine only.

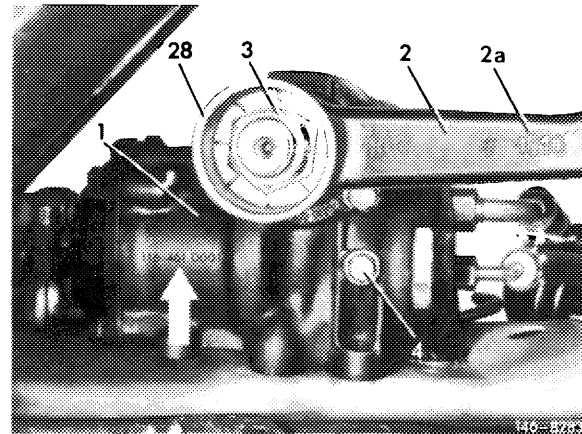

5 Pull pitman arm (2) from pitman shaft by means of puller (50).

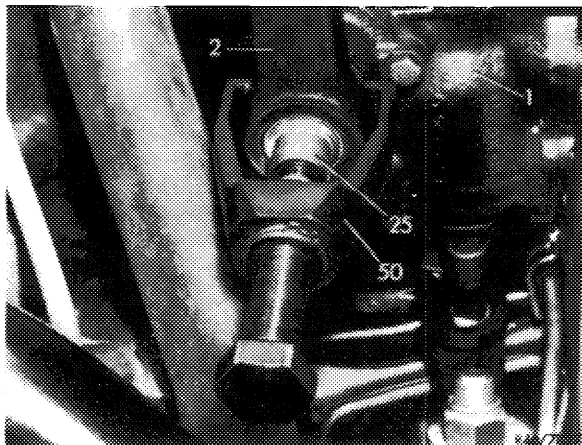

## Installation

6 The pitman arm cannot be checked with conventional workshop equipment. **When in doubt**, particularly following an accident, replace **pitman arm**.

Watch out for correct code number (arrow) of pitman arm.

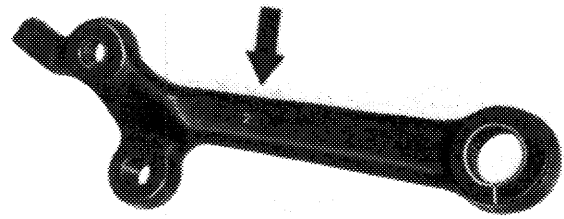

146-31417

7 Clean splining on pitman shaft and on pitman arm.

8 Slip pitman arm on pitman shaft, with marking on lever in alignment with marking on pitman shaft.

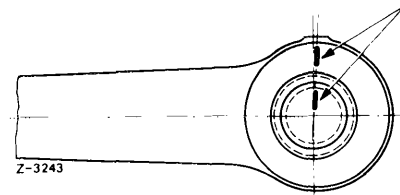

9 Screw new self-locking hex. nut (3) on pitman shaft and tighten to 160–200 Nm.

**Attention!**  
Always replace self-locking hex. nuts on principle.

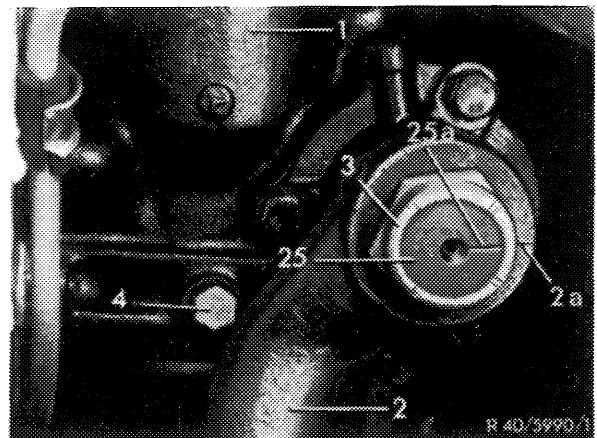

10 On vehicles with V-8 engine, slip protective cap (28) over self-locking hex. nut and attach with sleeve (030) by means of a few blows.

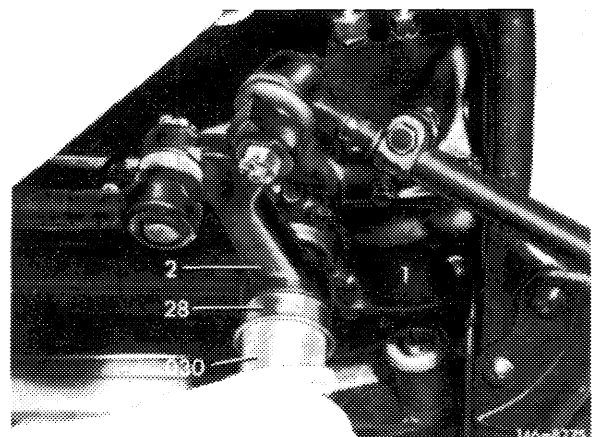

**Note:** The sleeve is self-made according to specified dimensions.

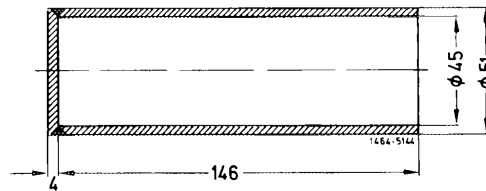

11 With drag link 1st version, check joint of drag link, for wear and replace drag link, if required. Place sealing ring (35) and plastic cover (33) on ball joint (46–550).

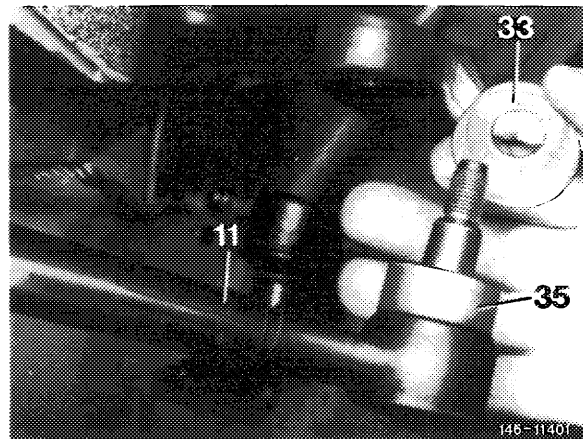

12 On drag link 2nd version, check rubber sleeve (32) on joint. If rubber sleeve is damaged, check ball joint for wear and replace drag link, if required (46–550).

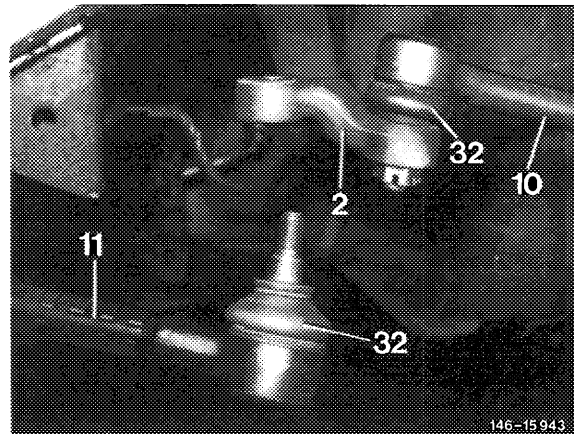

13 Check rubber sleeve (32) on joint of track rod. If the sleeve is damaged, check joint for wear and replace, if required (46–540).

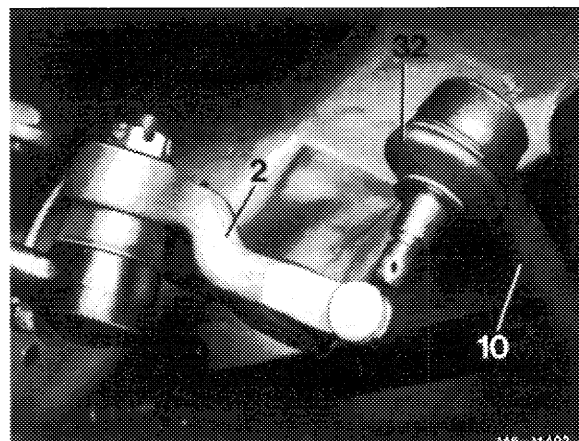

14 Attach track rod and drag link to pitman arm. Cotter castle nut. Tightening torque 35 Nm – reference value.

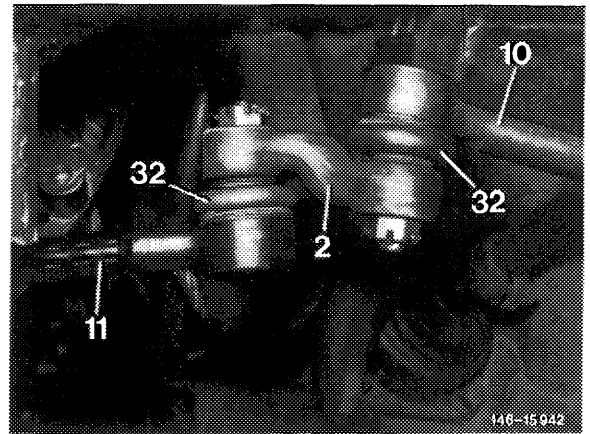

15 Check permissible steering lock by measuring dimension "a" between pitman arm or intermediate steering arm and stop bracket on frame cross member (40-320).

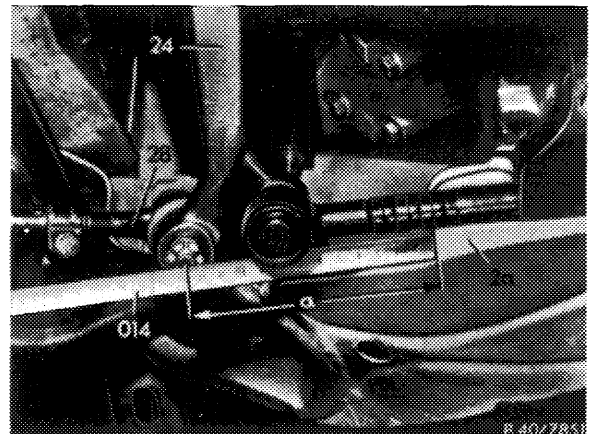

**Note:** The steering lock stops are on pitman arm or intermediate steering arm. At max. steering lock the respective arm should rest against stop bracket of frame cross member.

16 Check wheel adjustment values on front axle (40-320).

