

46–412 Removal and installation of power steering

Data

Steering	Part No.	Steering version	Model	Reaction piston dia. 1)	Ball circuit pitch position	Ratio in center position i =	Total ratio in center position i =
765.702	116 460 08 01	LL	116.02	10	10.5	13.92	14.02
	116 460 09 01	RL					
	116 460 10 01	LL	116.032				
	116 460 11 01	RL	116.033				
765.703	116 460 12 01	LL	116.120	9	10.5	13.92	14.02
	116 460 13 02	RL					

1) The value of reaction piston dia. ("8" or "9") has been punched-in on closing cap for control valve.

Oil grades/filling capacity and oil level checkup

ATF or transmission oil	refer to Specifications for service products page 236.2 refer to Specifications for service products page 237
-------------------------	--

Filling capacity approx. 1.5 liter

Oil level checkup With the oil at operating temperature (approx. 80° C), the oil level in supply tank should be at the punched-in or cast-in mark (approx. 20 mm below rim of tank). With cold oil and at ambient temperature, oil level 6–8 mm below mark. For filling up, use only absolutely clean oil since even minute particles of dirt might cause trouble in hydraulic system.

Tightening torques	Nm	(kpm)
Locking screws for fastening steering to side member of frame	70–80	
Pitman arm to pitman shaft	160–200	
Hex. socket screws to steering coupling	25	
Castle nut to track rod and drag link	35	
High-pressure expanding hose to steering	25–30	
Return tube to steering	35–40	

Special tools

Puller for ball joints of track rod on pitman arm, intermediate steering arm and steering knuckle arm

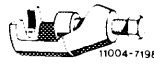

186 589 10 33 00

Puller for ball joints of drag link on pitman arm and intermediate steering arm

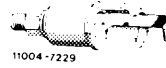

123 589 09 33 00

Puller for pitman arm

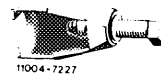

100 589 04 33 00

Check screw for center position of steering



116 589 06 21 00

Self-made tools

Assembly pin

refer to illustration item 20, note

Sleeve

refer to illustration item 29, note

Removal

1 Drain oil from supply tank of powersteering pump (1) with syringe, while removing upper stabilizing plate from tank, if required.

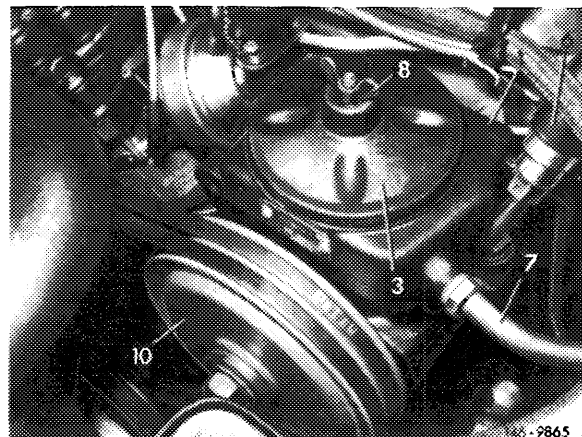

2 Loosen high-pressure expanding hose (26) and return line (28) on connection while applying counterhold to connecting members. Close oil hoses and connecting points on steering with blind plugs.

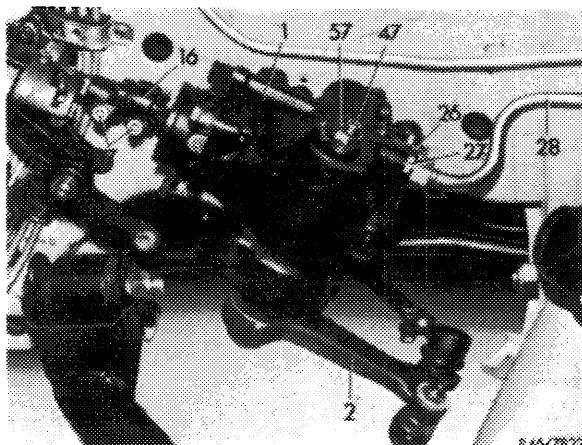

3 Unscrew lower hexagon screw (13) from steering coupling (12).

4 Remove steering shaft (46–630 item 2 to 5). However, pull steering shaft upwards only to the extent that steering coupling is no longer entering steering worm.

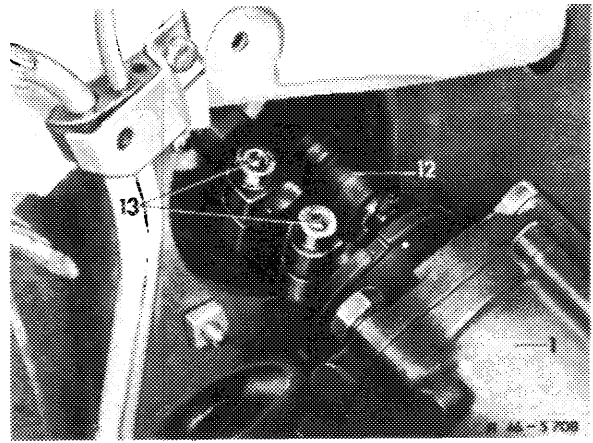

5 Uncotter castle nut of drag link and track rod and unscrew castle nut.

Note: When the steering is exchanged and the pitman arm is not replaced, the drag link and the track rod need not be released on steering arm.

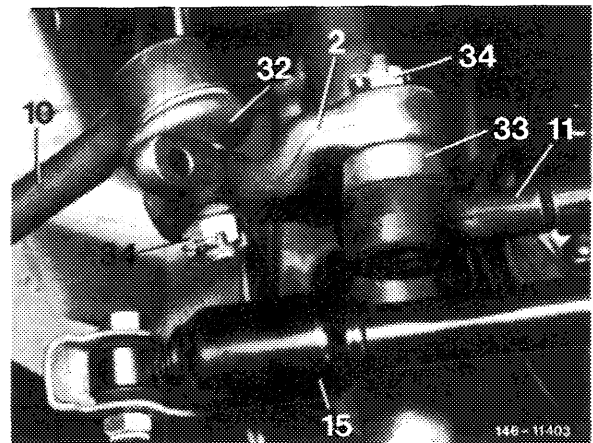

6 Force ball joint of track rod (10) from pitman arm by means of puller (065).

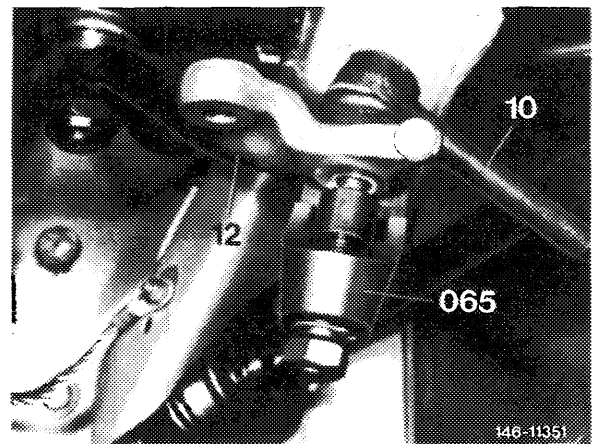

7 Force ball joint of drag link (11) from pitman arm by means of puller (066). On 1st version of drag link, pay attention to plastic covering ring and to sealing washer.

Note: To prevent damaging rubber sleeve on drag link 2nd version, force drag link off only with modified puller 123 589 09 33 00.

Use puller 123 589 00 33 00 only if puller bell has been refinished.

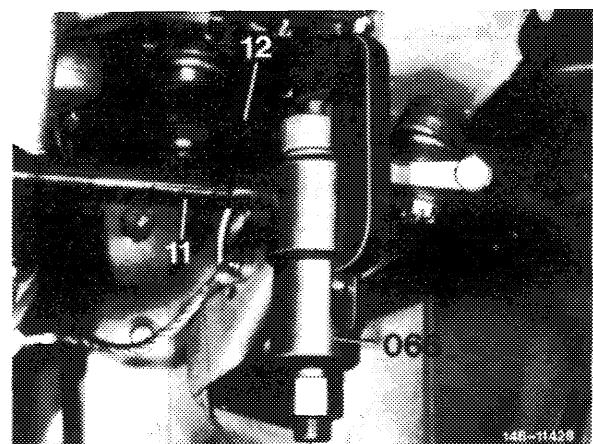

8 Unscrew self-locking hex. nut (3) from pitman shaft.

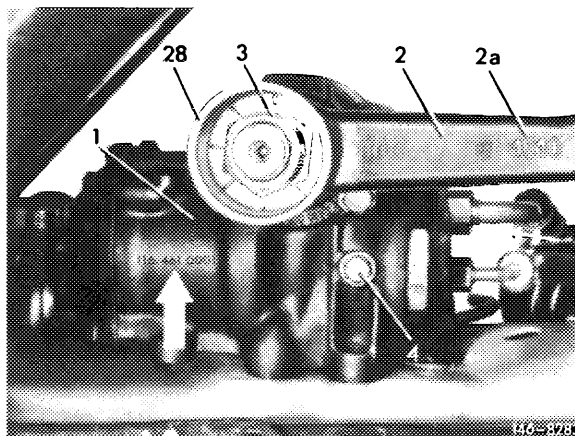

9 Pull pitman arm from pitman shaft by means of puller (50).

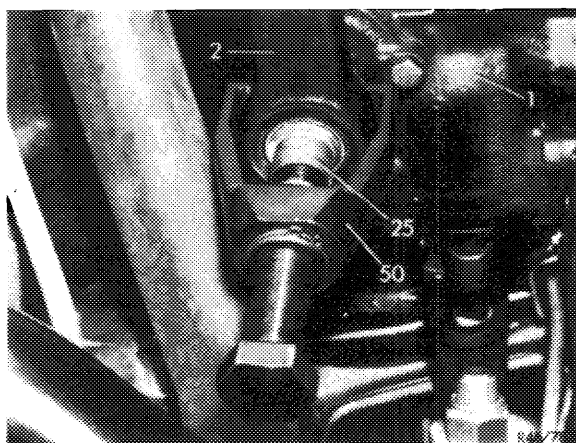

10 Unscrew locking screws (1) attaching steering to side member of frame. Then remove steering in downward direction.

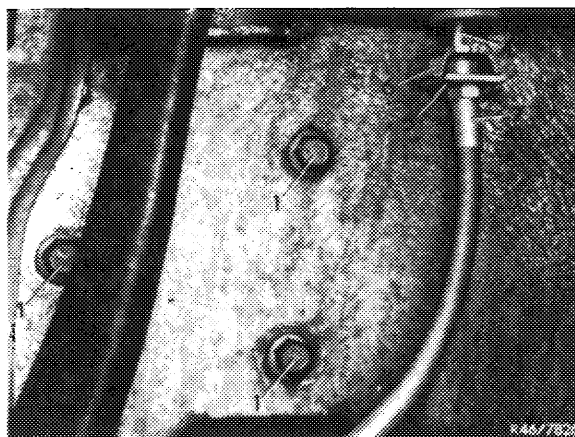

11 Upon removal of steering, drain oil from steering housing while turning steering worm completely to the left and right.

12 Remove steering coupling from steering shaft.

Installation

Note: When a new steering is installed, make sure

- a) that only a type of steering may be installed, on which either the part No. cast into steering housing begins with the number 116 (arrow)

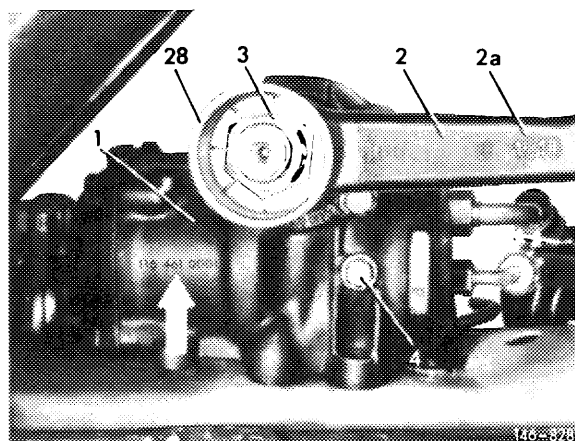

b) or the code no "8" or "9" is punched into closing cover for control valve (arrow).

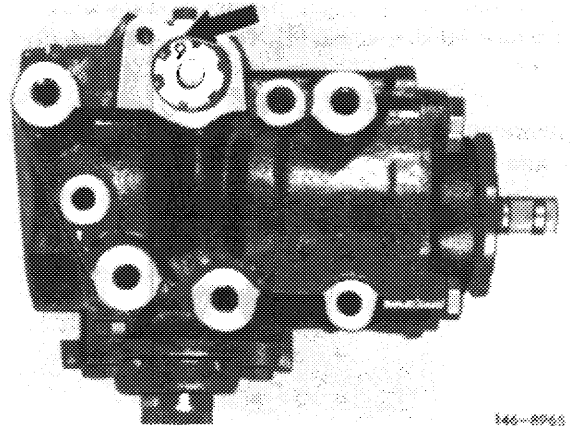

Attention!

Following repairs as a result of an accident, when one of the side members or the front end have been straightened or replaced, or when the jacket tube has been removed, check alignment between steering shaft and steering worm. For this purpose, install steering and complete jacket tube **without steering coupling**. A vertical and lateral offset of 2 mm between steering shaft and steering worm is permitted. Alignment may be corrected by displacing jacket tube at cross member or cover plate on front end. Attention should be paid to perfect location of steering lock cap in cutout of instrument panel.

13 Prior to installation, check steering coupling for wear and recondition or replace, then slip steering coupling on steering shaft, screw-in hex. socket screw, but do not yet tighten.

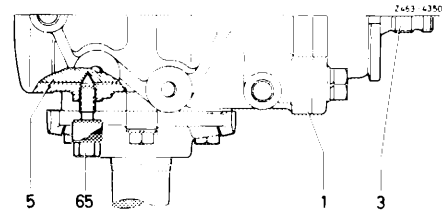

14 Unscrew closing plug from steering housing, turn steering worm (3) until center in power piston (5) is accurately under threaded bore.

15 Screw center-position check screw (060) into steering housing and locate power piston.

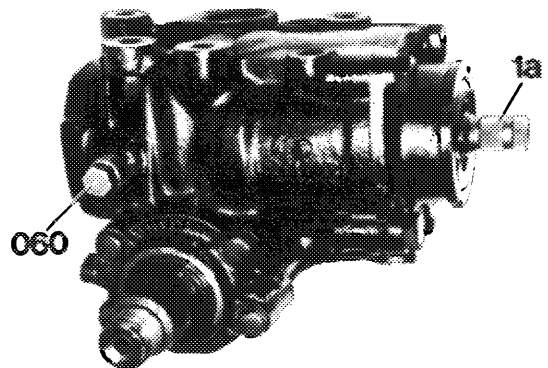

16 Attach steering to side member of frame with **three new** locking screws (1). Tightening torque 70–80 Nm.

Attention!

Be sure to use new locking screws each time.

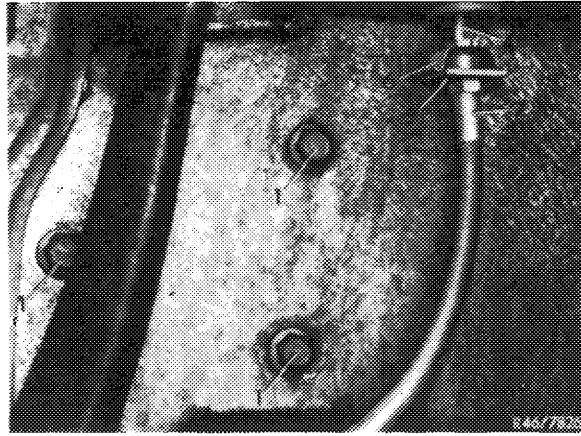

17 Turn steering shaft until return cam for combination switch is in center of jacket tube and that the mark (2a) on steering shaft points upwards. Then introduce steering coupling into splining of steering worm.

Note: Make sure that steering shaft is not displaced axially when inserting steering coupling into steering worm.

18 Attach bearing body (12) to jacket tube. Install combination switch (10).

19 Install steering wheel (46–610).

Note: On vehicles with jacket tube 1st version, the length adjustment of the steering shaft can be checked through bore in jacket tube. For this purpose, insert assembly pin (25) into check bore of steering shaft.

In jacket tube 2nd version, which is installed starting end of 1977, the steering shaft is no longer provided with a check bore.

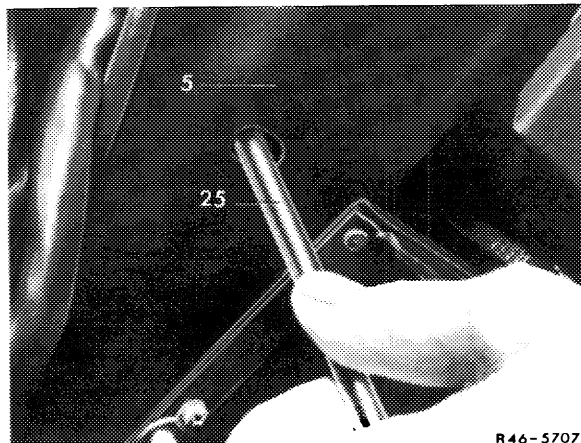
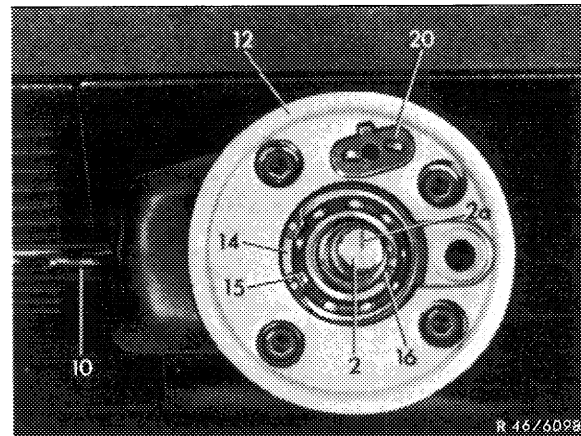

Note: The assembly pin is self-made according to dimensions shown in illustration.

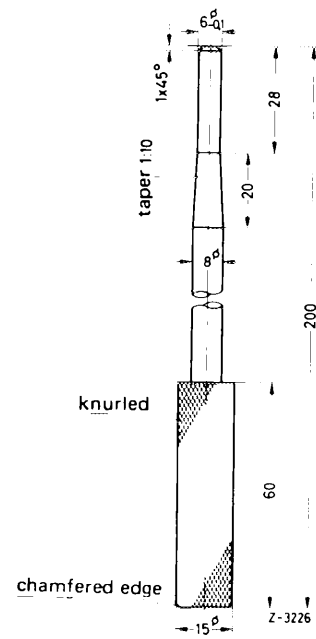

20 Unscrew center position check screw, screw closing plug (4) into steering housing while using a new copper sealing ring. Remove assembly pin from steering shaft.

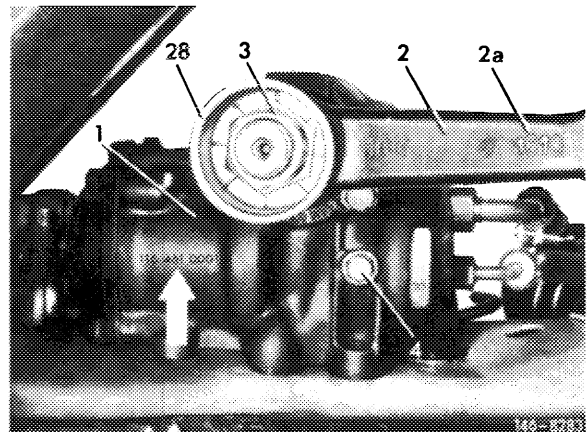

21 Screw hex. socket screw (13) into lower flange of steering coupling (12) and tighten both hex. socket screws. Tightening torque 25 Nm – reference value.

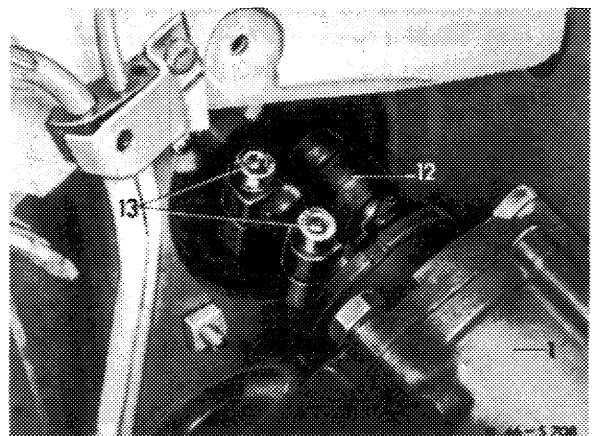

22 Slide pitman arm on splining of pitman shaft while paying attention to markings (arrow) on arm and on pitman shaft.

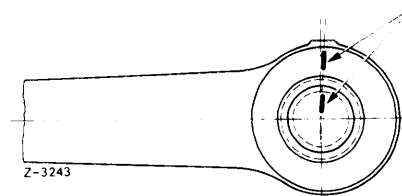

Note: The pitman arm must be marked with the correct code number (arrow):

Code No.	Model
1610	116.02, 116.032/033, 116.120 LL
1611	116.02, 116.032/033 RL
1612	116.036 LL
1613	116.036 RL

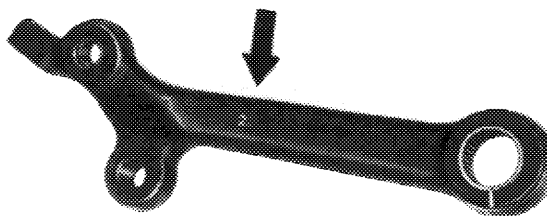

146 - 11417

23 Attach pitman arm with a new self-locking hex. nut (14). Tighten hex. nut to 160–200 Nm.

Attention!
Be sure to replace self-locking hex. nut on principle.

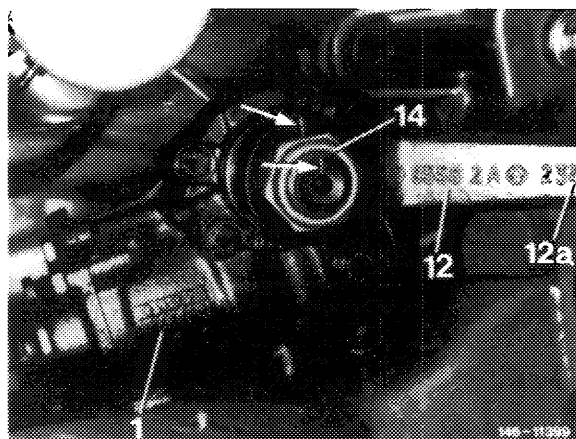

24 Check rubber sleeve (32) on joint of track rod (10). If the sleeve is damaged, check joint for wear and replace, if required. (46–540).

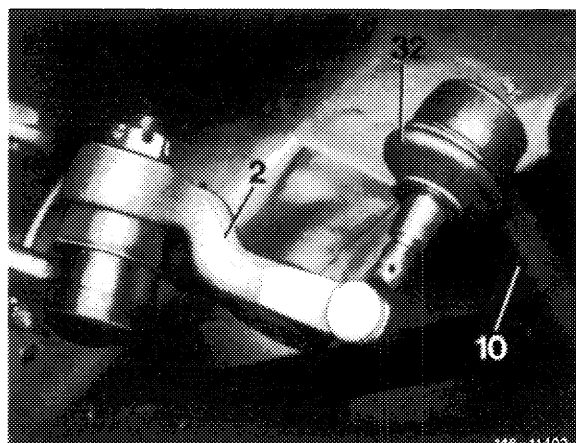

25 On drag link 1st version, check joints of drag link for wear and replace drag link, if required. Place sealing ring (35) and plastic cover (33) on ball joint.

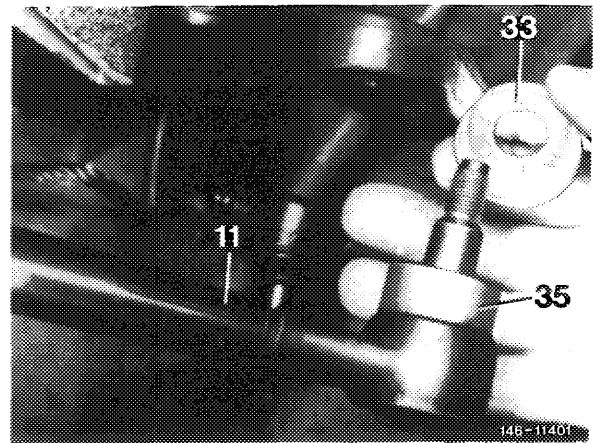

26 On drag link 2nd version, check rubber sleeve (32) on joint. If sleeve is damaged, check joint for wear and replace drag link, if required (46–550).

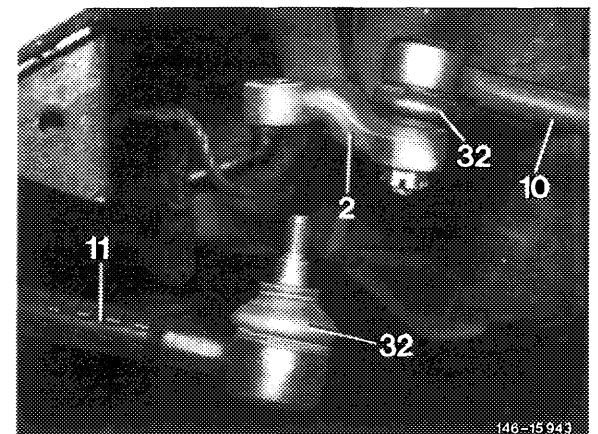

27 Attach drag link and track rod to steering knuckle arm cotter castle nut. Tightening torque 35 Nm – reference value.

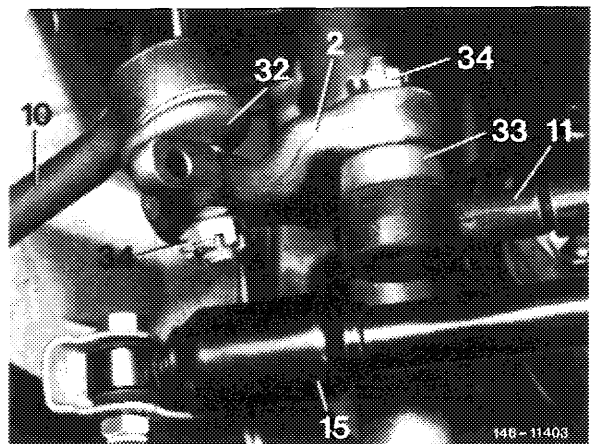

28 Check permissible steering lock by measuring reference dimension between pitman arm or intermediate steering arm and stop bracket of frame cross member (40–320).

Note: The steering lock stops are on pitman arm and intermediate steering arm. At max. steering lock the respective arm should rest against stop bracket (15a) of frame cross member.

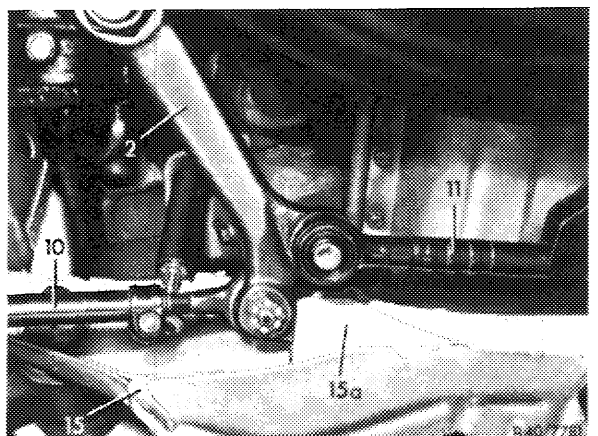

29 On vehicles with V-8 engine, slip protective cap (28) over self-locking hex. nut and attach with sleeve (030) by means of a few blows.

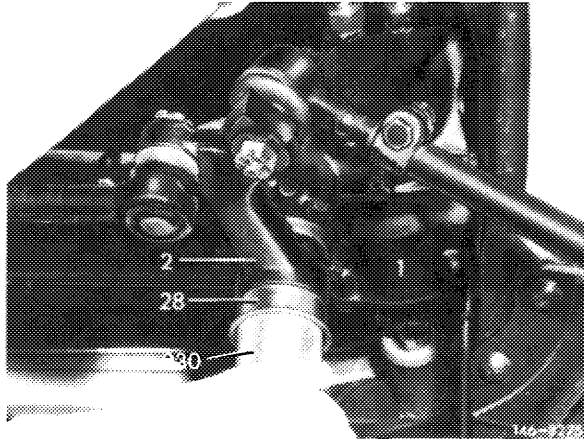

Note: Sleeve is self-made according to specified dimensions.

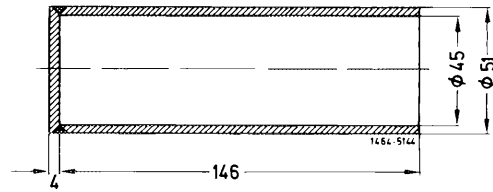

30 Remove blind plugs. Connect high-pressure expanding hose and connecting pipe for return flow hose.

Attention!

Make sure of perfect installation of hose. Even minor chafing marks may soon result in oil losses and thereby cause failure of hydraulic support. On vehicles with V-8 engine, also check hose connections on oil cooler pipe (1) for leaks.

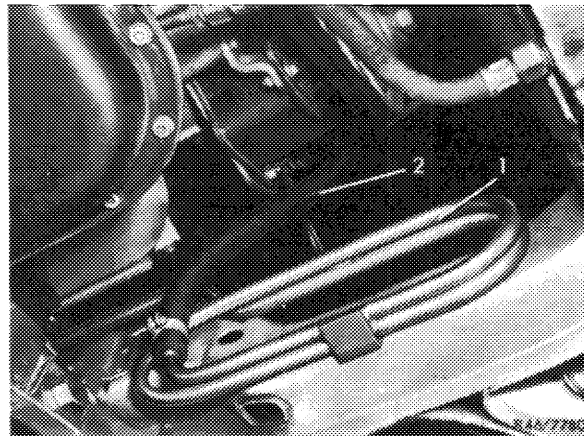

31 Fill supply tank of power steering pump with specified oil type.

32 Run engine and turn steering several times to the left and right while adding oil.

Note: The steering is self-venting.

33 Check wheel adjustment on front axle (40–320).

