

33–430 Replacement of sleeves for supporting and guide joint of steering knuckle bearing

Lubricant

Type of grease	Longterm grease refer to Specifications for service products, page 266.2	
Quantity of grease between housing and sleeve	Supporting joint and guide joint	5–6 grams

Special Tools

Assembly sleeve for wire clamping ring of supporting joint sleeve



116 589 03 14 00

Assembly sleeve for wire clamping ring of guide joint sleeve



116 589 02 14 00

Note

Sleeves damaged during assembly jobs must be replaced immediately. **Never replace damaged or leaking sleeves on joints already in use.** In such a case, the supporting joint or upper control arm must be replaced on princibale.

Removal

- 1 Lift flat wire clamping ring (7d or 8d) at one end with screw driver and remove in direction of arrow.

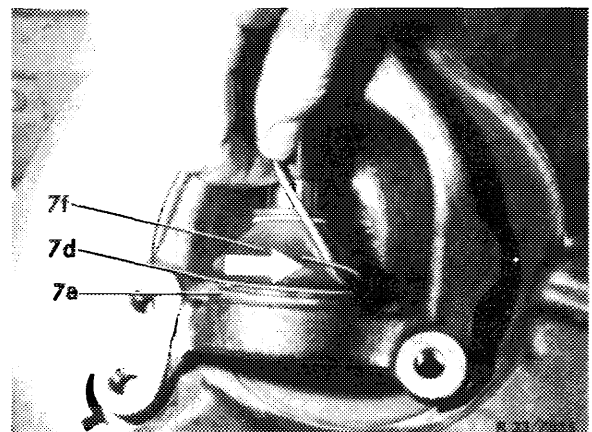

Supporting joint

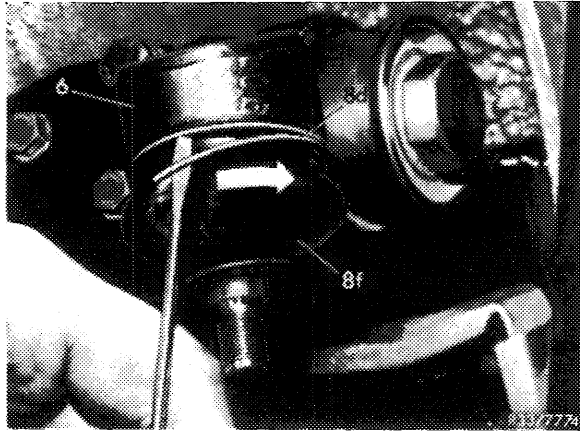

Guide joint

2 Remove sleeve (7f or 8f) and clean ball joint from old grease supply.

Attention!

Never wash ball joint.

Supporting joint

- 7a Housing
- 7b Ball shell
- 7c Ball pin
- 7d Wire clamping ring
- 7e Washer
- 7f Sleeve
- 7g Supporting ring
- 7h Wire clamping ring

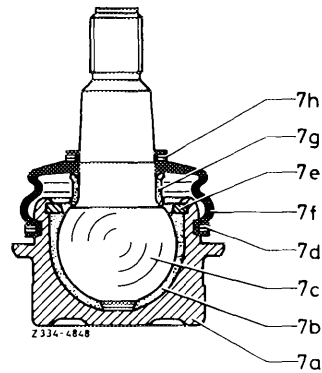

Guide joint

- 6 Upper control arm
- 8a End cover
- 8b Upper ball shell
- 8c Ball pin
- 8d Wire clamping ring
- 8e Ball shell
- 8f Sleeve
- 8g Supporting ring
- 8h Wire clamping ring

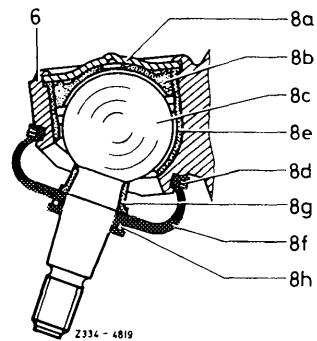

Installation

3 Fill space between housing (6 or 7a) and ball pin (7c or 8c) with fresh grease, making sure that the seat of the sleeve on the housing remains free of grease.

4 Set ball pin vertically and slip-on new sleeve with wire clamping ring (7h or 8h) inserted.

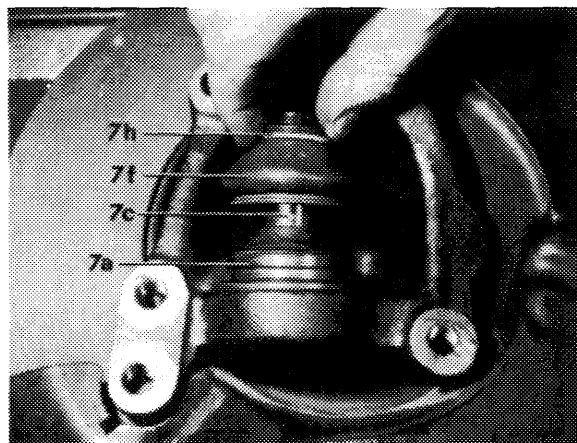

5 Slip wire clamping ring (7d or 8d) on respective assembly sleeve (09 or 010) until cylindrical portion of sleeve is attained.

6 Place assembly sleeve on supporting or guide joint in such a manner that the groove for wire clamping ring seat on sleeve remains just uncovered. Then slip wire clamping ring on sleeve of joint.

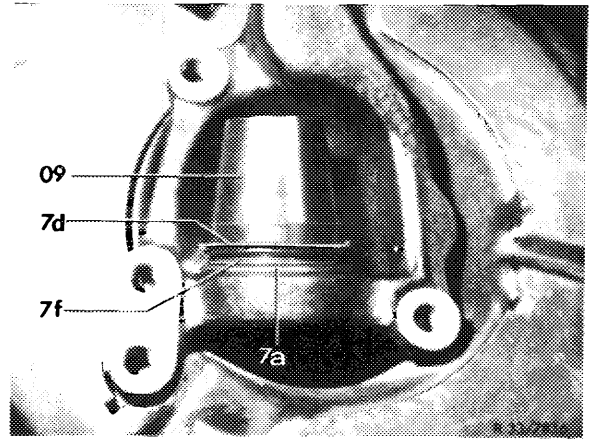

Attention!

Spit-on wire clamping ring (8d) of guide joint in such a manner that the cut points in driving direction.

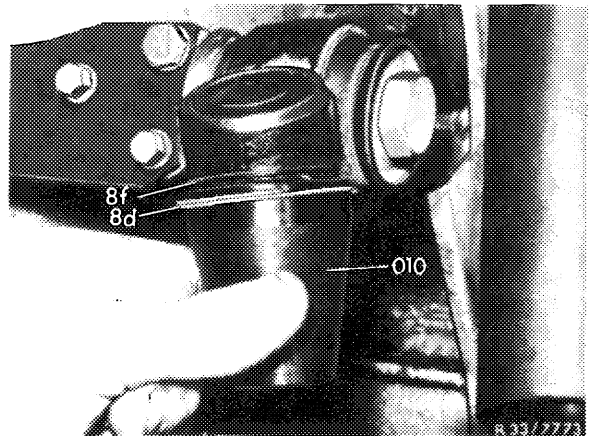

7 Check seat of assembled sleeve.

