

33-420 Removal and installation of steering knuckle arm

Data

Part no.	Code no.	for side
116 332 16 20	1616	lefthand
116 332 17 20	1617	righthand

Tightening torques

	Nm
Self-locking hex. head screw for fastening steering knuckle arm to steering knuckle	80
Castle nut to track rod	35

Special tool

Puller for ball joint of track rod on steering knuckle arm	186 589 10 33 00
--	------------------

Removal

- 1 Uncotter castle nut of track and unscrew castle nut.
- 2 Force ball joint of track rod from steering knuckle arm by means of puller.

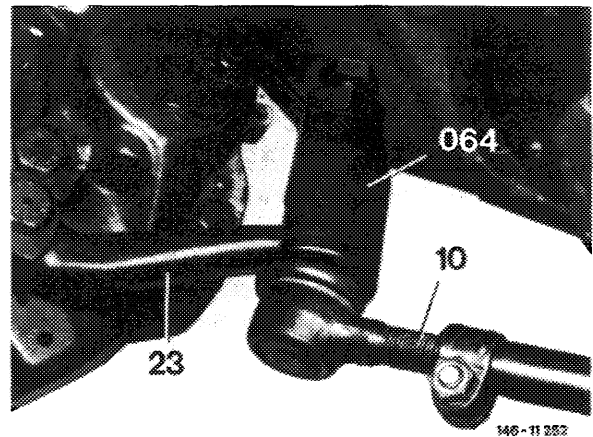

- 3 Unscrew both self-locking hex. head screws (20) from steering knuckle and remove steering knuckle arm.

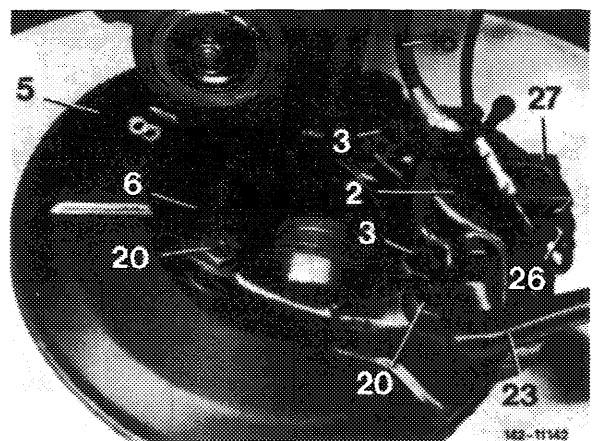

Checking

4 The steering knuckle arm cannot be checked with conventional shop equipment. If in doubt, particularly following an accident, install a new steering knuckle arm. Pay attention to correct code number (23a) of steering knuckle arm.



146-9777

Installation

5 Clean contact surface for steering knuckle arm on steering knuckle (6).

Note: If a new steering knuckle arm is installed, make sure that the contact surfaces for steering knuckle, the hex. head screws and the castle nut are free of paint.

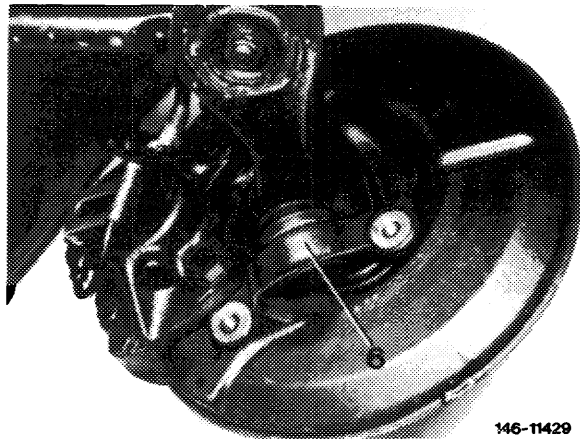

146-11429

6 Fasten steering knuckle arm with two new, self-locking hex. head screws (20) to steering knuckle. Tighten hex. head screws to specified torque of 80 Nm.

Attention!

Renew self-locking hex. head screws on principle.

7 Check rubber sleeve (32) on ball joint of track rod. If rubber sleeve is damaged, check ball joint for wear and renew, if required (46–540). Screw-in castle nut. Tightening torque of castle nut 35 Nm — reference value. Cotter castle nut.

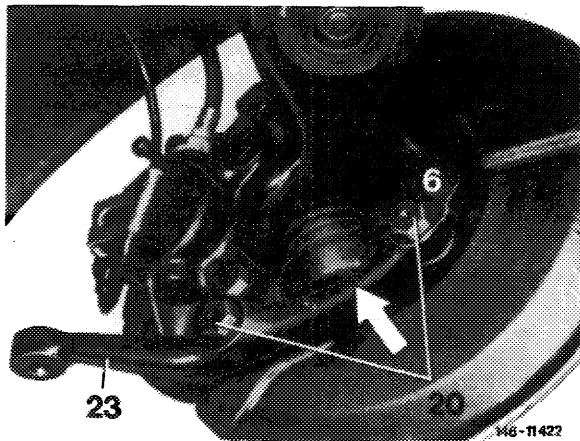

146-11422

8 Check wheel adjustment on front axle (40–320).

