



33-200 Removal and installation of front axle half

Tightening torques	Nm
Self-locking hex. socket screw for fastening rpm sensor to steering knuckle	8
Hex. bolts of cross yoke bearing on frame side member	140
Hex. bolt of upper control arm bearing on front end	80
Hex. socket clamping screw in clamping piece of upper control arm support	45
Eccentric bolt of lower control arm bearing	180
Hex. nut of track rod ball joint	35
Hex. socket screws or twelve-point bolts of lower shock absorber suspension	20
Hex. nuts of upper shock absorber suspension	tighten up to end of thread
Hex. screws for fastening clamping member to torsion bar	10
Hex. screws of torsion bar bearing on frame floor	20
Hex. screw of upper control arm support on torsion bar support 1st version without spacing sleeve ¹⁾	up to end of thread in clamping member
Hex. screw of upper control arm support on torsion bar support 2nd version with spacing sleeve ²⁾	100

¹⁾ Installed as standard equipment up to February 1979.

²⁾ Installed as standard equipment starting March 1979.

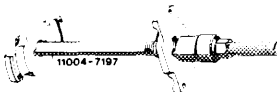
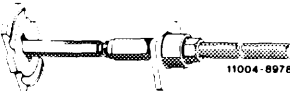
Special tools

Spring tensioner for front spring		116 589 06 31 00
Spring tensioner for front spring (removal-installation axle half complete)		123 589 04 31 00
Socket 32 mm 1/2" square 284 mm long for spring tensioner		201 589 01 09 00

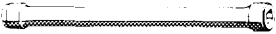
Socket 24 mm 1/2" square
450 mm long for spring tensioner 116 589 06 31 00  11004-8982 116 589 01 09 00

Contour plate (2 each)  11004-8980 116 589 01 32 00

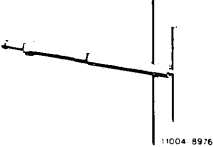
Socket wrench 5 mm for mounting upper shock
absorber  11004-8976 107 589 00 09 00

Pressing-off device for ball
joint of track rod  11004-7226 186 589 10 33 00

Note

The bearings of control arms at front end and of torsion bar on front wall, as well as the support of the upper control arms on torsion bar may be tightened only in ready-to-drive condition. When these bearings are tightened with wheels not carrying the proper load, wrong control arm position data would result.

During assembly jobs on upper control arm no distortion should occur via torsion bar. If required, slightly lift front axle half at lower control arm on opposite vehicle side.

The front shock absorber serves simultaneously as a deflection stop for front wheel. For this reason, loosen shock absorber suspension only when vehicle is resting on its wheels or when the lower control arm is supported. With the shock absorber released, the upper control arm rests on end stop at front end of vehicle. For assembly of upper suspension, either place vehicle on its wheels or raise axle half at lower control arm.

Renew self-locking screws and nuts!

Check brake lines and brake hoses very carefully (40-012).

For removal and installation of front springs and simultaneous removal and installation of front axle half, a pertinently designed spring tensioner has become valid (32-205).

Removal

- 1 Remove front shock absorber (11), making sure that the upper shock absorber suspension is released first (32–100).
- 2 Jack up vehicle at front, remove front wheels.
- 3 Remove front spring (12) (32–200 or 32–205).

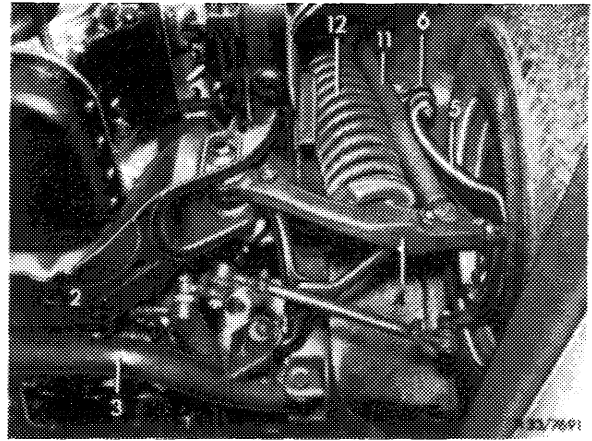

- 2 Frame cross member
- 3 Cross yoke
- 4 Lower control arm
- 5 Steering knuckle
- 6 Upper control arm
- 10 Torsion bar
- 11 Front shock absorber
- 12 Front spring
- 24 Pitman arm
- 27 Drag link
- 28 Track rod
- 29 Steering knuckle arm
- 33 Brake caliper
- 39 Brake hose

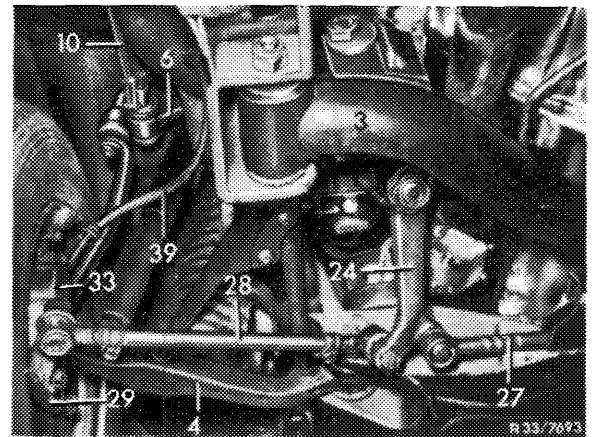

- 4 Loosen ball joint of track rod (28) on steering knuckle arm (29) and force-off with device (040).

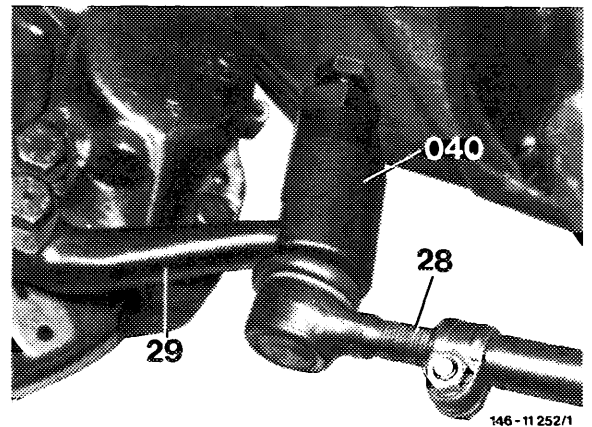

- 5 Separate brake line (40) and brake hose (39) on front end from each other. Loosen plug connection of brake lining wear indicator on fixed caliper. Close lines against penetration of dirt.

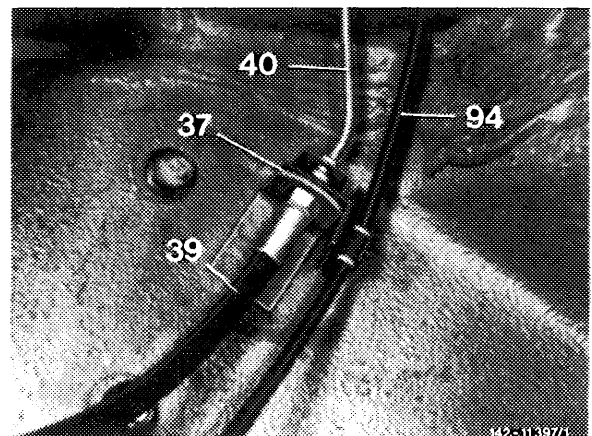

- 37 Holder for brake hose
- 39 Brake hose
- 40 Brake line
- 94 Cable of brake lining wear indicator

6 On vehicles with ABS, remove rpm sensor (42) by loosening hex. socket screw (42a) from steering knuckle (5) (42-712).

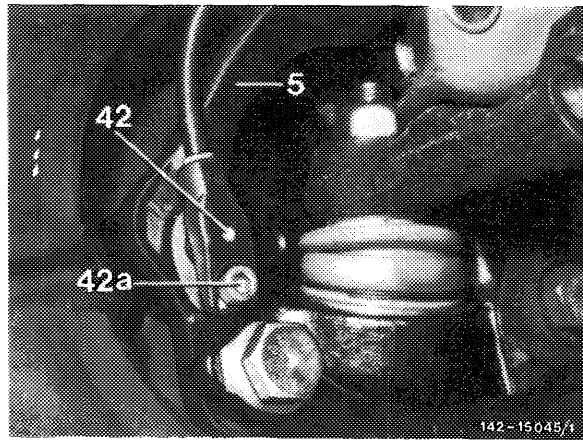

7 On bearing of lower control arm, mark position of the two eccentric bolts in relation to frame cross member or cross yoke.

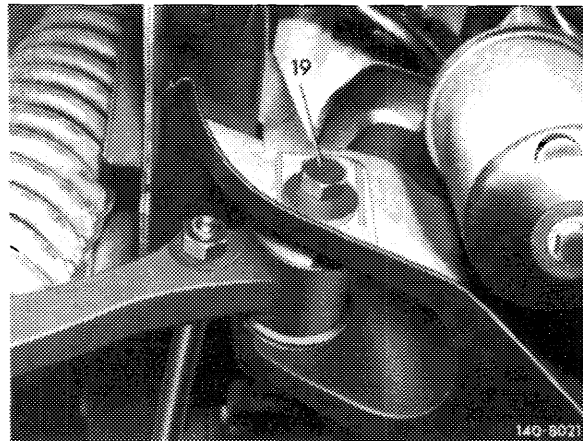

19 Front eccentric bolt
(camber adjustment)

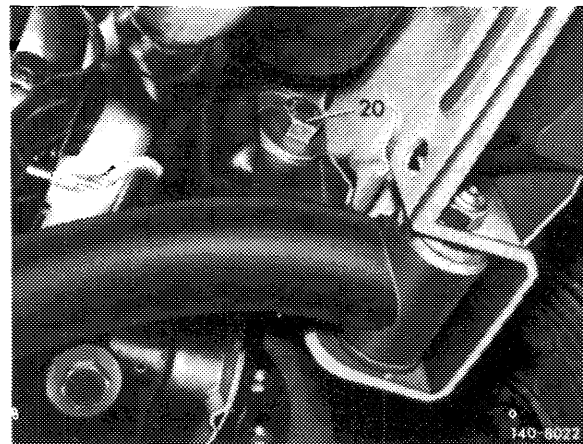

20 Rear eccentric bolt
(caster adjustment)

8 Unscrew shield on cross yoke.

9 Support front axle half.

10 Loosen eccentric bolt on front and rear bearing of lower control arm and knock out.

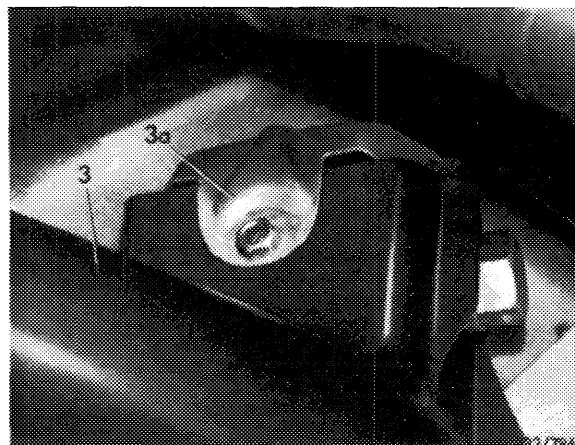

3 Cross yoke
3a Shield

11 Loosen hex. bolt of cross yoke bearing and remove; loosen screw at opposite end.

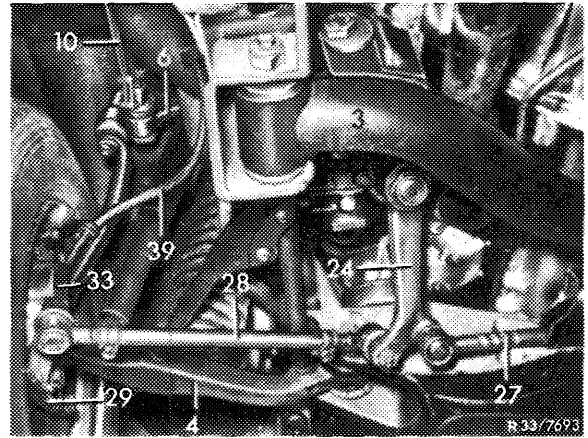

12 Pull cross yoke slightly downwards.

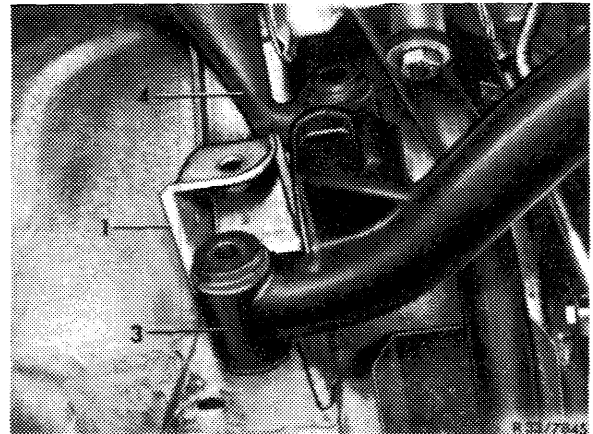

- 1 Frame side member
- 3 Cross yoke
- 4 Lower control arm

13 Loosen support of upper control arm on torsion bar. For this purpose, unscrew hex. socket clamping screw (22b) and hex. screw (22g) out of clamping piece.

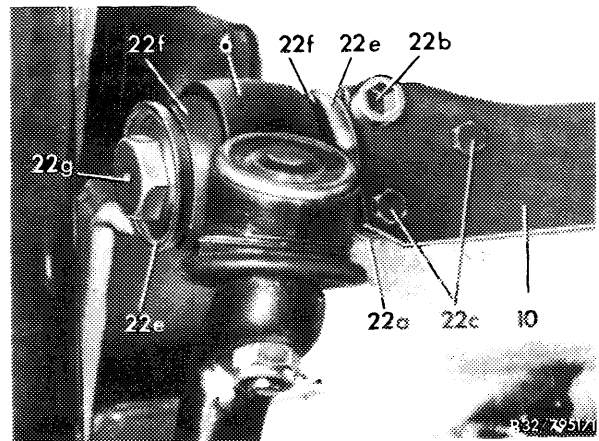

- 6 Upper control arm
- 10 Torsion bar
- 22a Clamping piece
- 22b Hex. socket clamping screw
- 22c Hex. screws with washers and self-locking hex. nuts
- 22e Cup washers
- 22f Rubber mounting
- 22g Hex. screw

14 Loosen hex. screw (18) of upper control arm bearing on front end from direction of engine compartment and remove.

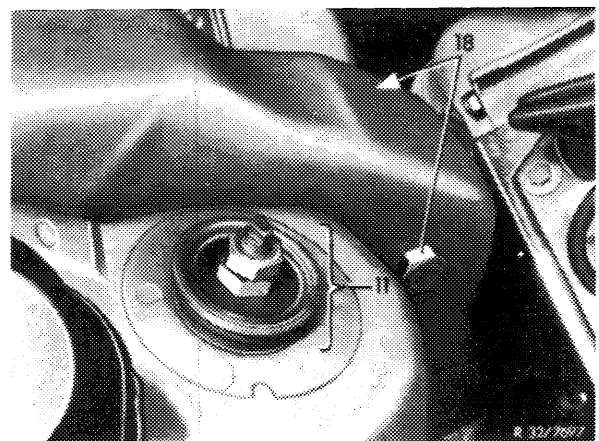

15 Remove front axle half.

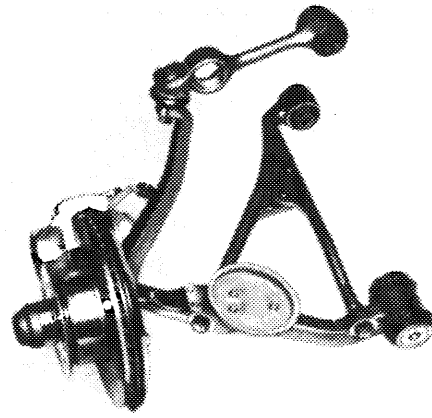

333-8019

Inspection

16 Check rubber mounting of upper and lower control arm, as well as rubber mounting for supporting upper control arm and renew, if required.

Installation

17 Introduce front axle half and mount upper control arm to front end and torsion bar, but do not tighten screws yet.

Lubricate threads of clamping screw (22b) prior to installation.

For this purpose, lift front axle half at opposite vehicle end accordingly to obtain a favorable position of torsion bar.

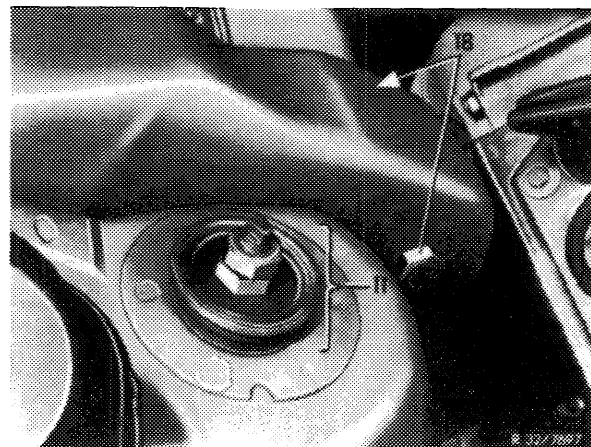
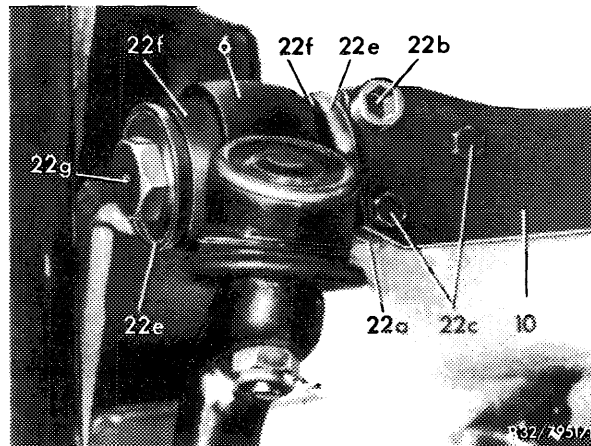

Upper control arm bearing at front end

11 Upper fastening of shock absorber

18 Hex. head screw

Bearing for upper control arm on front end

- 6 Upper control arm
- 18 Rubber mounting
- 38 Front end

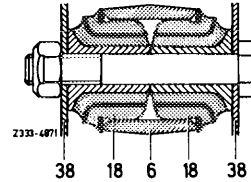

Support of upper control arm on torsion bar
1st version (up to January 1979)

- 6 Upper control arm
- 10 Torsion bar
- 22a Clamping piece
- 22b Hex. socket clamping screw
- 22c Hex. screws with washers and self-locking hex. nuts
- 22d Clamping sleeves
- 22e Cup washers
- 22f Rubber mounting
- 22g Hex. screw

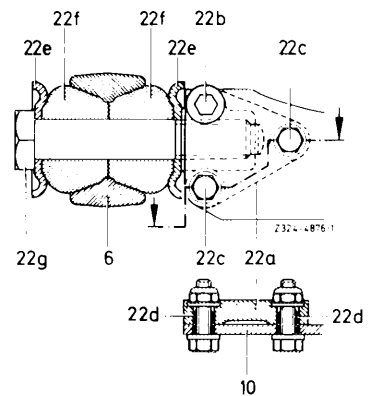

Support of upper control arm on torsion bar
2nd version (starting February 1979)

- 6 Upper control arm
- 22a Clamping piece
- 22b Hex. socket clamping screw
- 22c Hex. screws with washers and self-locking hex. nuts
- 22d Clamping sleeves
- 22e Cup washers
- 22f Rubber mounting
- 22g Hex. screw
- 22h Spacing sleeve

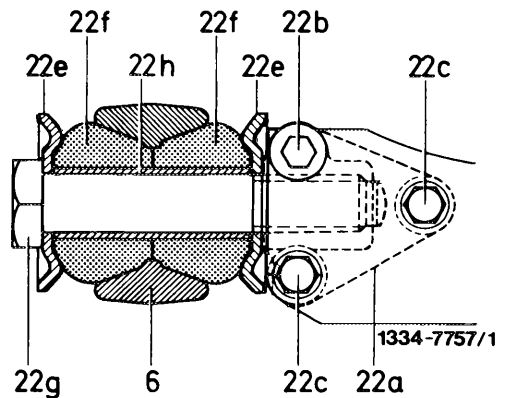

18 Mount front bearing of lower control arm to frame cross member.

Front bearing of lower control arm on frame cross member
1st version (up to August 1973)

- 2 Frame cross member
- 4 Lower control arm
- 16 Rubber mounting
- 19 Eccentric bolt

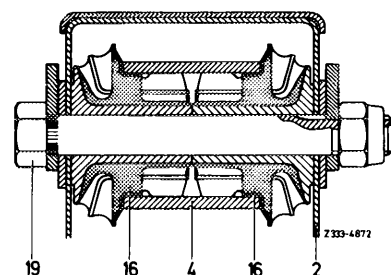

Front bearing of lower control arm
on frame cross member
2nd version (starting September 1973)

- 2 Frame cross member
- 4 Lower control arm
- 16a Axial slide bearing
- 16g Radial torsion bearing
- 19 Eccentric bolt

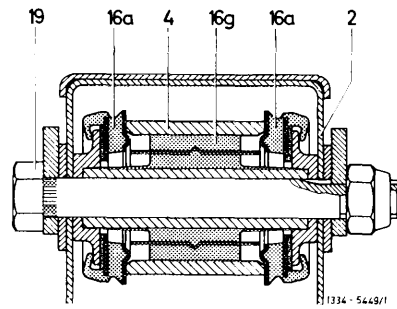

19 Attach cross yoke to frame side member.

Bearing of cross yoke to frame
side member

- 1 Frame side member
- 3 Cross yoke
- 15 Rubber mounting

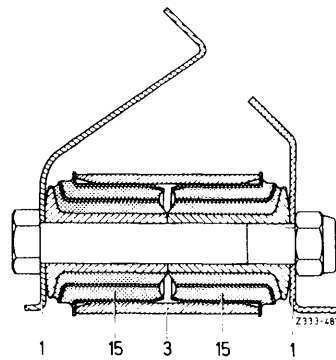

20 Mount rear bearing of lower control arm to cross
yoke.

Rear bearing of lower control arm
to cross yoke

- 3 Cross yoke
- 4 Lower control arm
- 17 Rubber mounting
- 20 Eccentric bolt

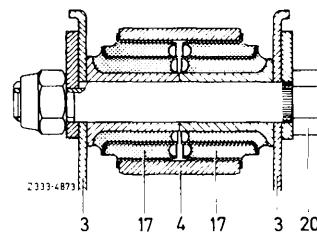

Attention!

The eccentric bolts of the control arm bearings are
of different length.

Front eccentric bolt: total length 150 mm

Rear eccentric bolt: total length 123 mm

21 Install front spring (32-200).

22 Mount front shock absorber (32-100).

23 Connect brake line and brake hose on front end to each other.

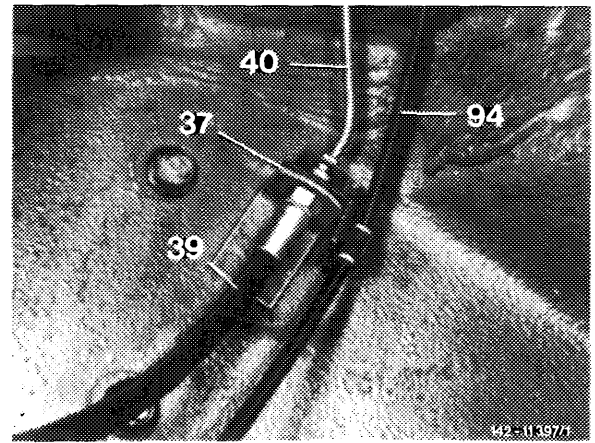

24 On vehicles with ABS, fasten rpm sensor (42) with hex. socket screw (42a) in steering knuckle (5) (42-712).

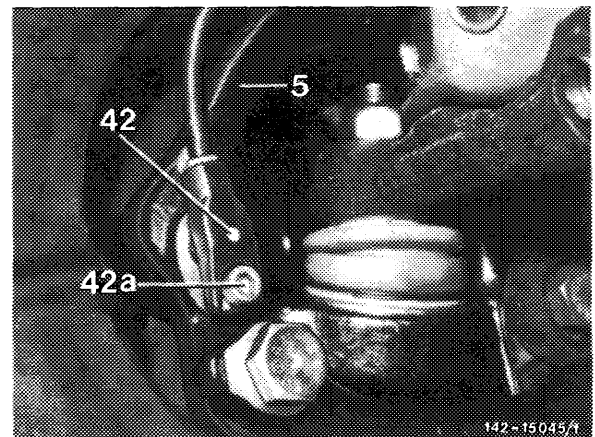

25 Bleed brakes (42-010).

26 Mount track rod to steering knuckle arm.

27 Mount front wheel, lower vehicle.

28 Set eccentric bolts of camber and caster adjustment on previously applied markings and tighten.

Attention!

If the position of the eccentric bolts has not been marked during removal, mount eccentric bolts in center position for initial adjustment.

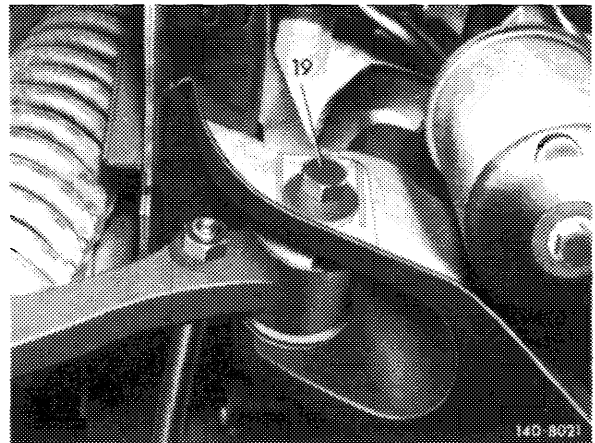

29 Tighten hex. screw of upper control arm bearing on front end.

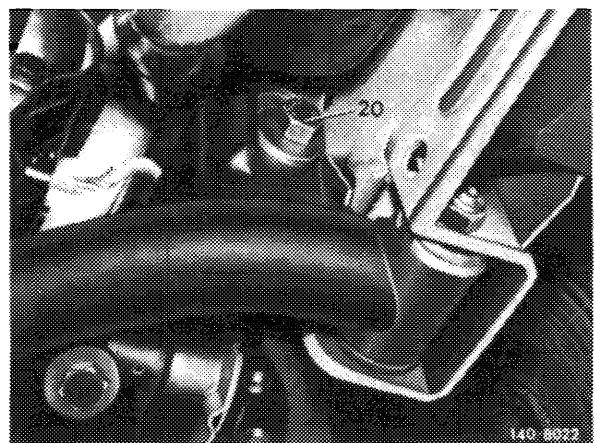

Bearing of upper control arm on front end

- 6 Upper control arm
- 18 Rubber mounting
- 38 Front end

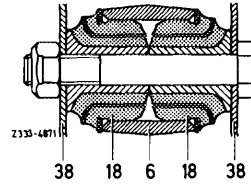

30 Mount support of upper control arm on torsion bar.

On support of 1st version, tighten hex. head screw (22g) up to end of threads in clamping piece and tighten hex. head clamping screw (22b).

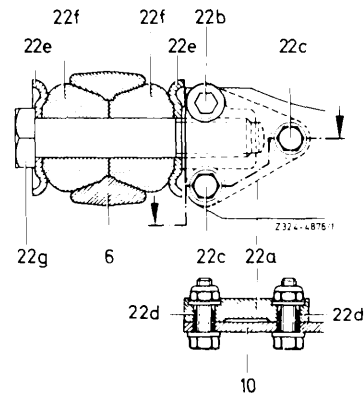

On support of 2nd version with spacing sleeve, tighten hex. head screw (22g) to specified torque, also tighten clamping screw (22b).

Attention!

Clamping sleeves should be flush with torsion bar.

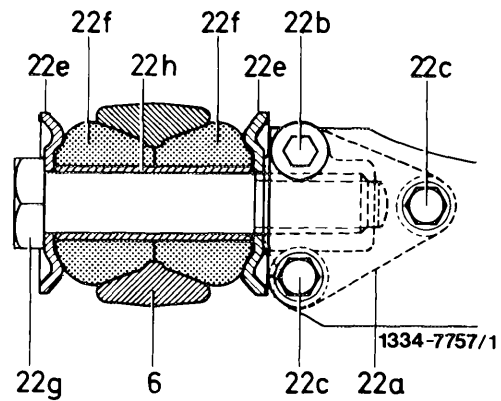

31 Check vehicle level on front axle.

32 Check adjustment of front wheels and correct, if required (40–320).

33 Check adjustment of headlamps.