

Data

Torsion bar Part no.	Diameter	Rubber mount of torsion bar bearing			
		Part no.	Bore dia. „a”	Eccentricity „b” of bore	Identifi- cation
116 323 42 65	24	116 323 26 85	22	–	–
		116 323 30 85		3	blue color dot

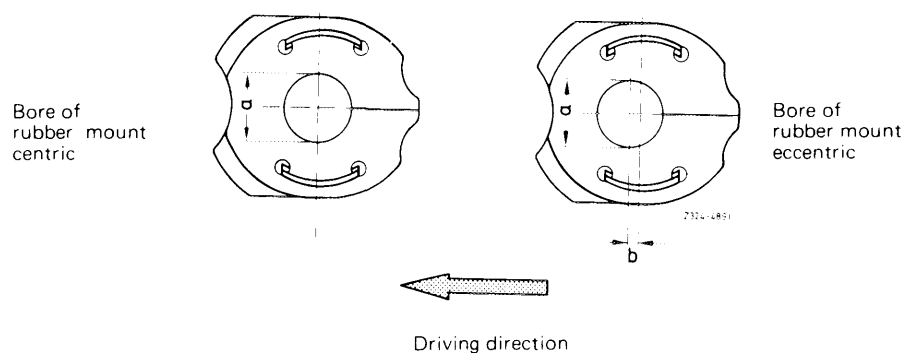

Tightening torques	Nm	(kpm)
Hex socket clamping screw in clamping piece	45	(4.5)
Hex bolts for attaching clamping piece to torsion bar	10	(1)
Hex bolts of torsion bar bearing on frame floor	20	(2)
Hex bolt of upper control arm support on torsion bar 1st version without spacing sleeve ¹⁾	up to end of threads in clamping piece	
Hex bolt of upper control arm support on torsion bar support 2nd version with spacing sleeve ²⁾	100	(10)

¹⁾ Standard up to February 1979.
²⁾ Standard starting March 1979.

Note

- a) To prevent any distortion of upper control arm support on torsion bar during assembly jobs, attach supporting stands used when jacking up the vehicle not against frame floor but against lower control arm.
- b) The rubber mounts of the torsion bar bearing on front end may vary to compensate for body tolerances (refer to table and illustration).

During installation, make sure that the rubber mounts are again located at the same spot to prevent any changes of front wheel caster.

- c) Mount and tighten torsion bar bearing on front end and upper control arm support on torsion bar only in the position corresponding to a condition ready for driving.

d) In the event of repairs on upper control arm support on torsion bar, install only rubber mounts with spacing sleeve 2nd version.

e) Lubricate hex socket clamping screw in clamping piece on torsion bar prior to assembly.

Removal

- 1 Lift vehicle at the front, place supporting jacks outside front against control arm. Remove front wheels.
- 2 Loosen hex head clamping screw (22b) on clamping piece (22a) and unscrew hex screw (22g) of upper control arm support of torsion bar.

8 Guide joint	22 Upper control arm support
10 Torsion bar	on torsion bar

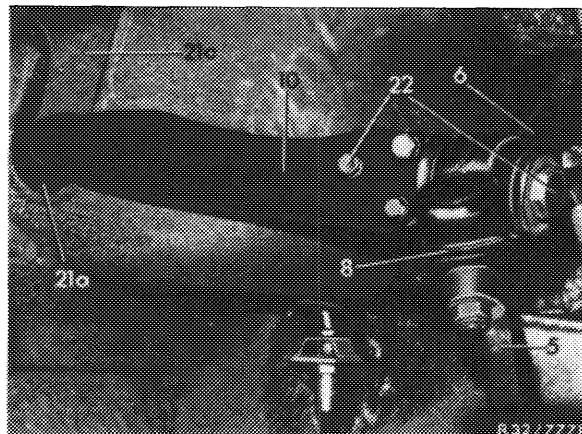

- 3 Loosen the two hex screws (22c) of clamping piece left and right on torsion bar and remove clamping pieces.
- 4 Remove tandem main cylinder and brake unit.
- 5 Remove air cleaner, water hoses and regulating linkage, disconnect electric cables of injection valves.

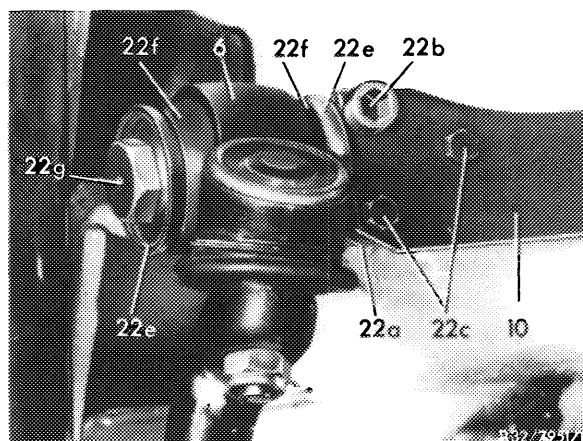

6 Upper control arm
10 Torsion bar
22a Clamping piece
22b Hex head clamping screw
22c Hex bolts with washers
and self-locking hex nuts
22e Cup washers
22f Rubber mount
22g Hex bolt

6 Loosen hex bolt and hex nut of torsion bar bearing on frame floor left and right, remove holding clip.

Attention!

On rubber mounts (21a) of torsion bar bearing on front end left and right the arrangement of the bores may vary (refer to table and illustration).

Torsion bar bearing left

- | | |
|------------------|---------------------|
| 10 Torsion bar | 21b Holding bracket |
| 21a Rubber mount | 21c Cover |

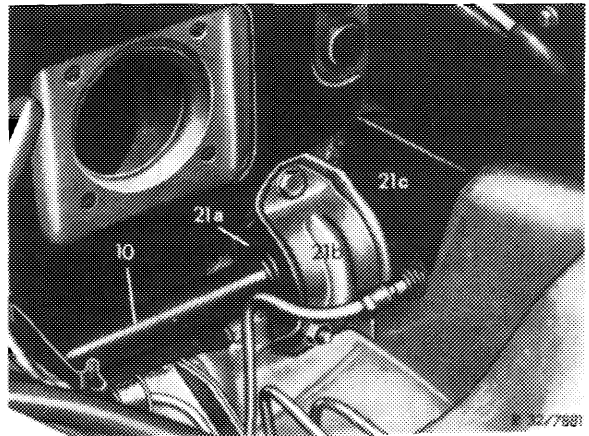

7 Mark rubber mount with „left“ and „right“ and remove from torsion bar.

8 Remove covers right and left on wheel house.

9 Remove torsion bar.

Torsion bar bearing right

- | | |
|---------------------|-----------|
| 10 Torsion bar | 21d Cover |
| 21b Holding bracket | |

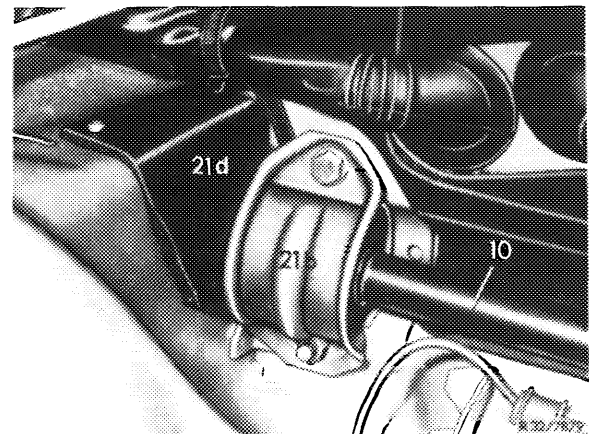

Inspection

10 Check rubber mount of torsion bar bearing on frame floor and support of upper control arm on torsion bar.

Installation

11 Introduce torsion bar in such a manner that the curved sides of the torsion bar arms are facing forward. In installed condition, the curved sides are facing upwards.

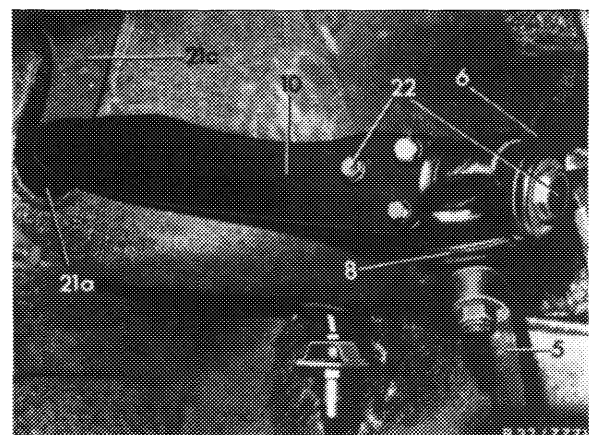

12 Attach clamping pieces left and right to torsion bar.

Attention!

Clamping sleeves should terminate flush with torsion bar.

13 Mount support of upper control arm on torsion bar, while tightening 1st version of hex head bolt (22g) up to end of threads in clamping piece and also tightening hex head clamping screw (22b).

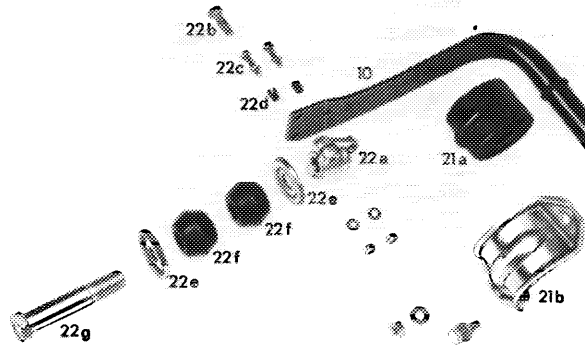

132-8020

For support 2nd version with spacing sleeve tighten hex head bolts (22g) to specified torque and also tighten clamping screw (22b).

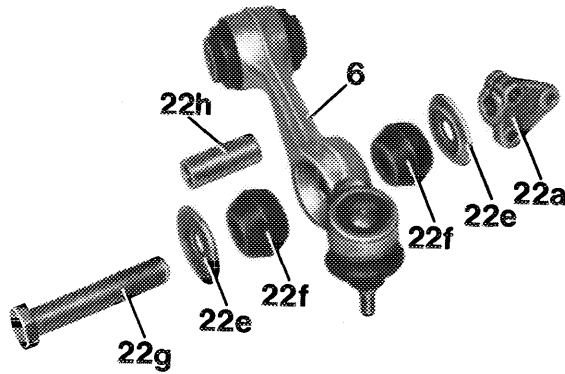

133-15453

- | | |
|---|---|
| 6 Upper control arm | 22c Hex screws with washers and self-locking hex nuts |
| 10 Torsion bar | 22d Clamping sleeves |
| 21a Rubber mount | 22e Cup washers |
| 21b Holding bracket | 22f Rubber mount |
| 22a Clamping piece | 22g Hex bolt |
| 22b Hex head clamping screw or hex socket head clamping screw | 22h Spacing sleeve |

1st version

- | | |
|---|---|
| 6 Upper control arm | 22c Hex screws with washers and self-locking hex nuts |
| 10 Torsion bar | 22d Clamping sleeves |
| 21a Rubber mount | 22e Cup washers |
| 21b Holding bracket | 22f Rubber mount |
| 22a Clamping piece | 22g Hex bolt |
| 22b Hex head clamping screw or hex socket head clamping screw | |

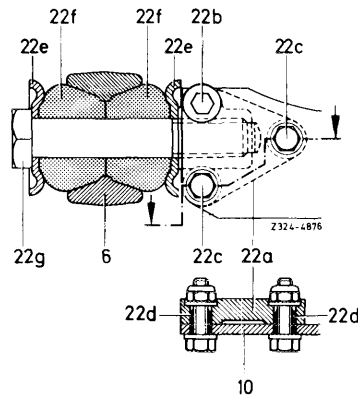

2nd version

- | | |
|---|----------------------|
| 6 Upper control arm | 22d Clamping sleeves |
| 22a Clamping piece | 22e Cup washers |
| 22b Hex head clamping screw or hex socket head clamping screw | 22f Rubber mount |
| 22c Hex screws with washers and self-locking hex nuts | 22g Hex bolt |
| | 22h Spacing sleeve |

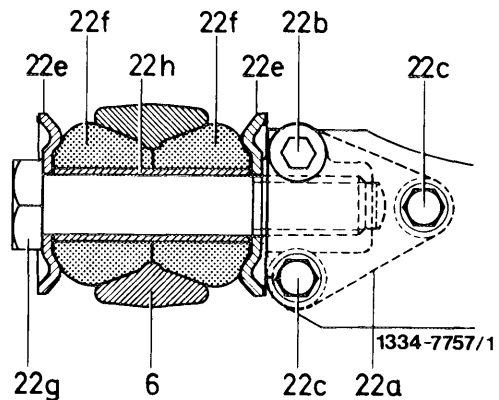

Attention!

When fitting hex bolt (22g) make sure that the rubber mounts are not distorted in control arm eye. Lubricate threads of clamping screw M 10 x 30 prior to insertion.

- 14 Attach covers left and right on front end.
- 15 Slide rubber mount of torsion bar bearing on front end left and right onto torsion bar with parting slot toward the rear while watching mark applied during removal. Mount holding bracket with hex screws and hex nuts.
- 16 Mount regulating linkage, water hoses and electric cables of injection valves.
- 17 Install tandem main cylinder and brake unit.
- 18 Mount air cleaner.
- 19 Mount front wheels, lower vehicle.
- 20 Check adjustment of wheels on front axle and re-adjust, if required (40–320).

- 10 Torsion bar
- 21a Rubber mount
- 21b Holding bracket
- 38 Front end

