

# Retighten fastening bolts of bearing pins for lower control arm of front axle

# 922

Models 108 109 111 113

## Tightening torque

	Nm	(kpm)
Hex. bolts M 12 x 1.5 of bearing pins for lower control arms	130	(13)

## Special tool

Torque wrench 0–25 kpm	000 589 25 21 00 or conventional
------------------------	----------------------------------

- Check hex. bolts of bearing pins, left and right 4 each, for tight seat and retighten, if required.

**Attention!** Locked by means of snap ring. Do not loosen bolts.

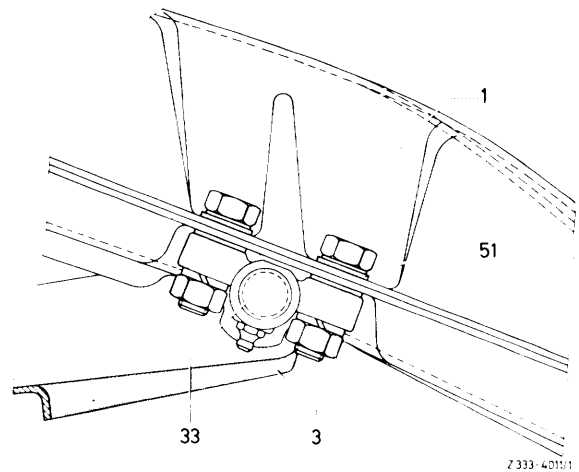

- |                      |                |
|----------------------|----------------|
| 1 Front axle carrier | 33 Bearing pin |
| 3 Lower control arm  | 51 Washer      |

