

V-belt B Power Steering Pump

- Loosen screw (1) on face of power steering pump.

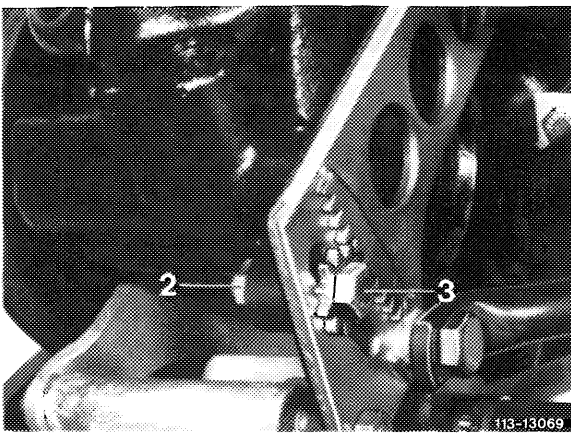

- Loosen nut (2).
- Tension V-belt with tensioning screw (3).
- Tighten nut (2) and screw (1).

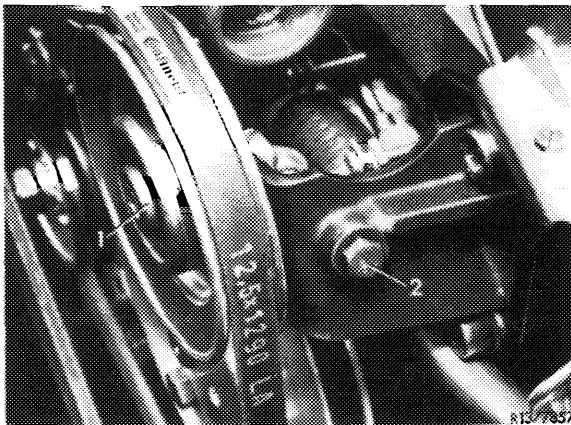

V-belt C Refrigerant Compressor

- Loosen necked-down screw (1).
- Tension V-belt with tensioning screw (2).
- Tighten necked-down screw (1) to 16 Nm (1.6 kpm).

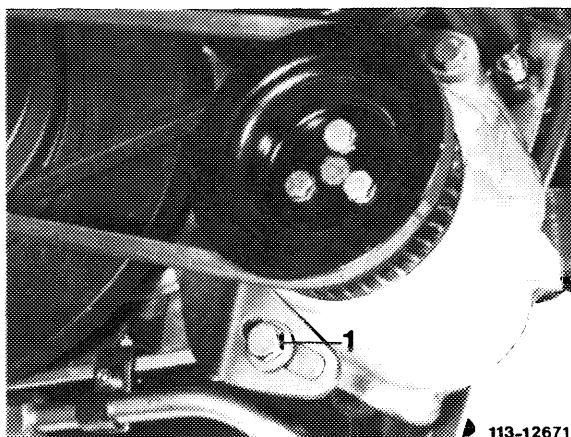

V-belt D Air Pump

- Loosen fastening screw (1).
- Tension V-belt by swivelling air pump in outward direction.
- Tighten fastening screw (1).

V-belts	Deflection in mm at 60 N (6 kp) load
A	approx. 10
B	approx. 5
C	approx. 10

- | | |
|--------------|--------------------------|
| 1 Crankshaft | 4 Refrigerant compressor |
| 2 Water pump | 5 Tensioning roller |
| 3 Alternator | 6 Power steering pump |

Note

The V-belts are tensioned correctly if they just yield elastically to strong thumb pressure.

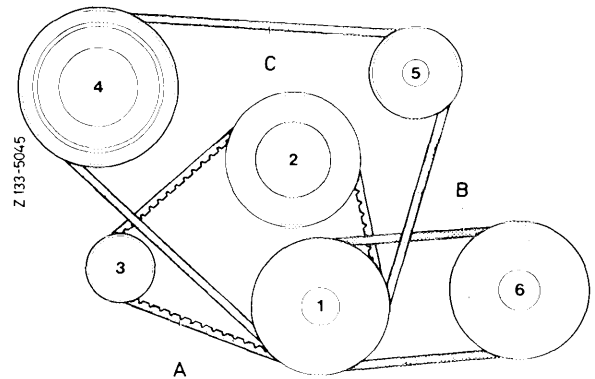

V-belt A Alternator – Water Pump

Version up to August 1973

- Loosen counter-nut (1) and fastening screw (2).
- Tension V-belt with tensioning nut (3).
- Lock tensioning nut and tighten fastening screw.

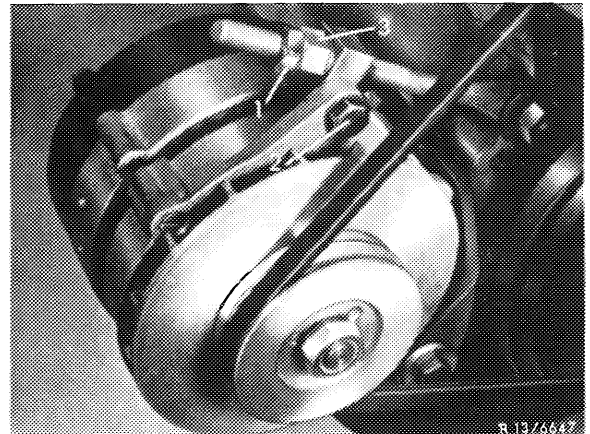

Double V-belt A Alternator – Water Pump

- Loosen fastening screw (1).
- Push alternator outwards by means of a lever. (With air conditioner, from below).
- Tighten fastening screw (1) and retighten fastening screws (2) and (3).

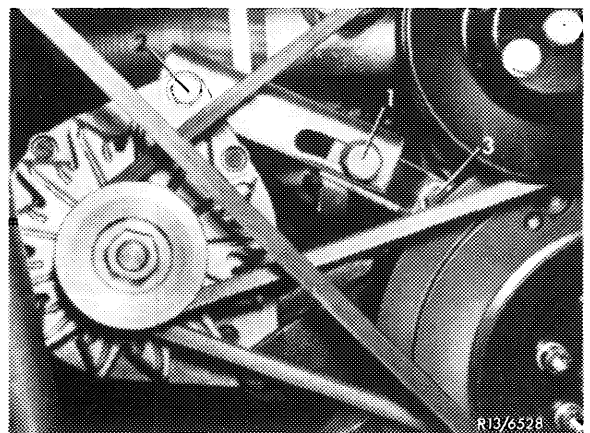

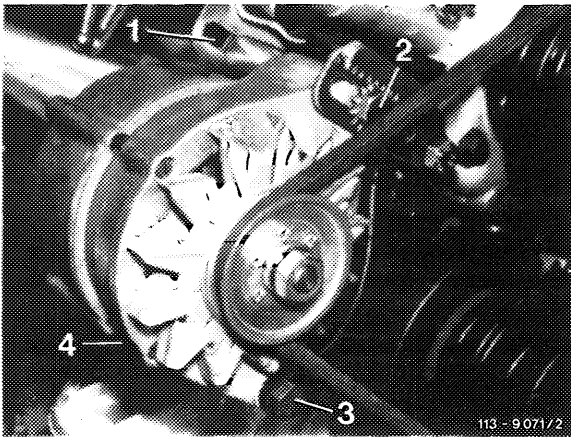

V-belt A Alternator – Water Pump

Version starting August 1973

- Loosen nut (4) of fastening screw (3) and nut (1) of tensioning screw (2).
- Tension V-belt with tensioning screw (2) and tighten nut (1).
- Tighten nut (4) of fastening screw (3).

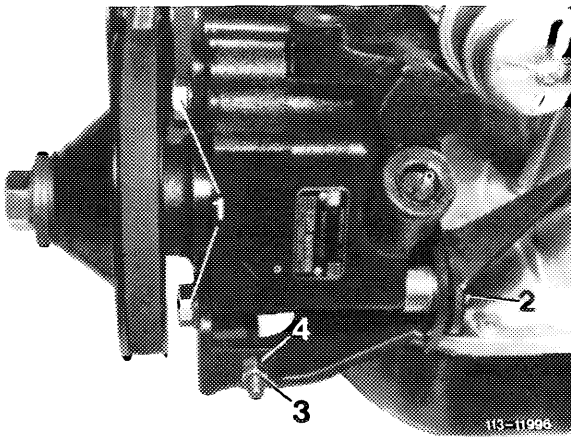

V-belt B Power Steering Pump

- Loosen fastening screws (1) and (2), as well as counter-nut (3).
- Tension V-belt with tensioning nut (4).
- Tighten fastening screws (1 and 2), as well as counter-nut (3).

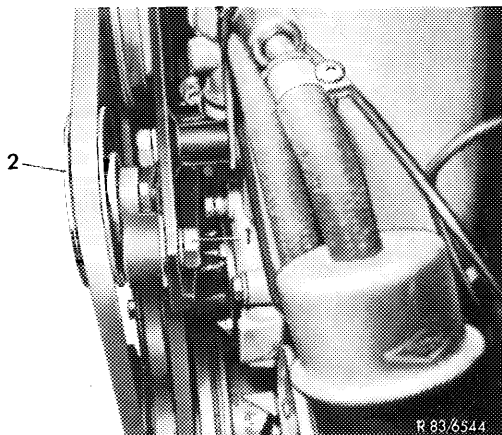

V-belt C Refrigerant Compressor

- Loosen fastening screw (1).
- Tension V-belt by swivelling tensioning roller (2).
- Tighten fastening screw.

V-belts	Layout	Deflection in mm at 60 N (6 kp) load
A	Alternator – water pump	approx. 10
B	Refrigerant compressor	
C	Power steering pump	approx. 5
D	Vacuum pump	approx. 10

Note

The V-belts are tensioned correctly if they just yield elastically to strong thumb pressure.

Belt drive

Model year 1972

- | | |
|--------------|--------------------------|
| 1 Crankshaft | 4 Refrigerant compressor |
| 2 Water pump | 5 Tensioning roller |
| 3 Alternator | 6 Power steering pump |

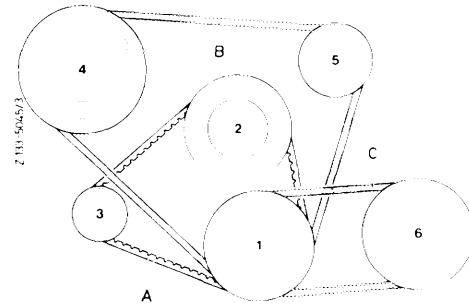

Belt drive

Model year 1973/1974

- | | |
|--------------------------|-----------------------|
| 1 Crankshaft | 5 Tensioning roller |
| 2 Water pump | 6 Power steering pump |
| 3 Alternator | 8 Vacuum pump |
| 4 Refrigerant compressor | |

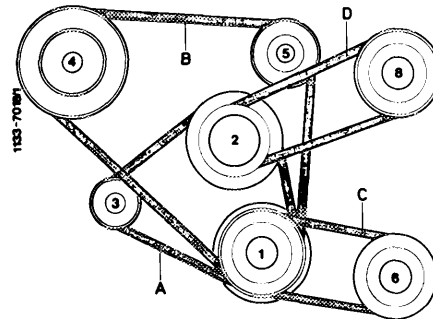

V-belt A Alternator – Water Pump

Model year 1972 up to including 1973

- Loosen counter-nut (1) and fastening screw (2).
- Tension V-belt with tensioning nut (3).
- Lock tensioning nut and tighten fastening screw.

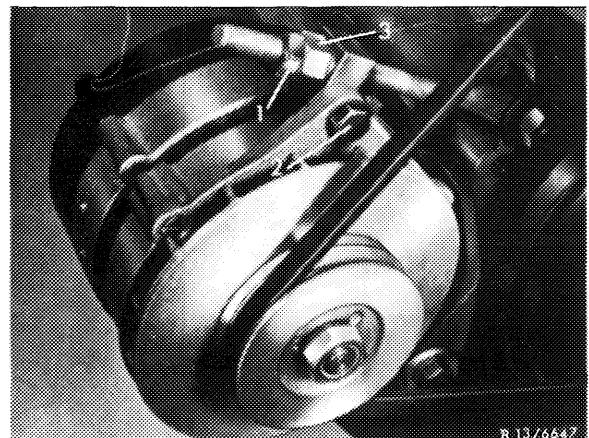

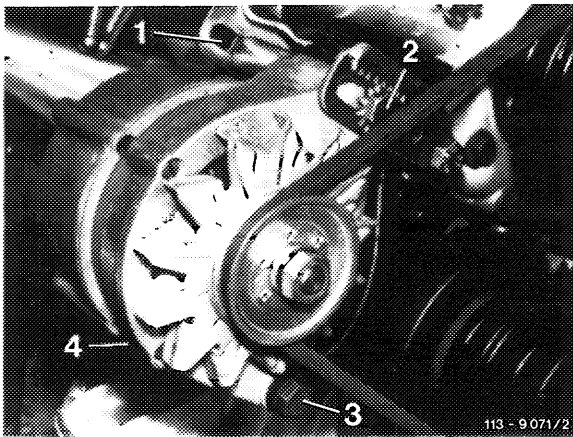
**V-belt A Alternator – Water Pump**

Model year 1974

- Loosen nut (4) of fastening screw (3) and nut (1) of tensioning screw (2).
- Tension V-belt with tensioning screw (2) and tighten nut (1).
- Tighten nut (4) of fastening screw (3).

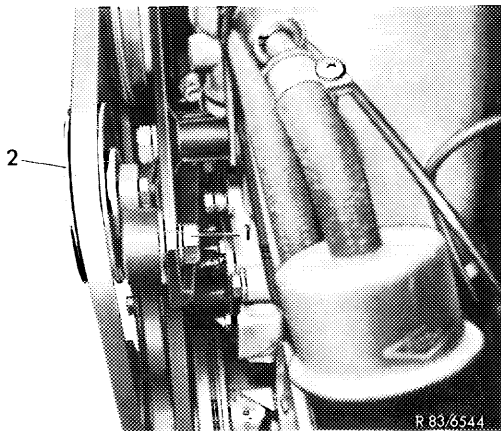
**V-belt B Refrigerant Compressor**

- Loosen fastening screw (1).
- Tension V-belt by swivelling tensioning roller (2).
- Tighten fastening screw.

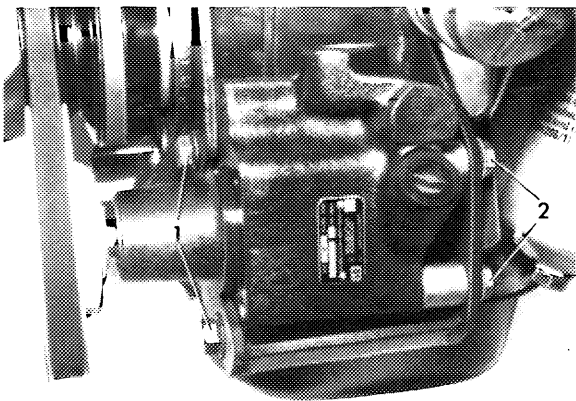
**V-belt C Power Steering Pump**

- Loosen fastening screws (1 and 2).
- For tensioning V-belt, push power steering pump by means of a lever in outward direction.
- Tighten fastening screws (1 and 2).

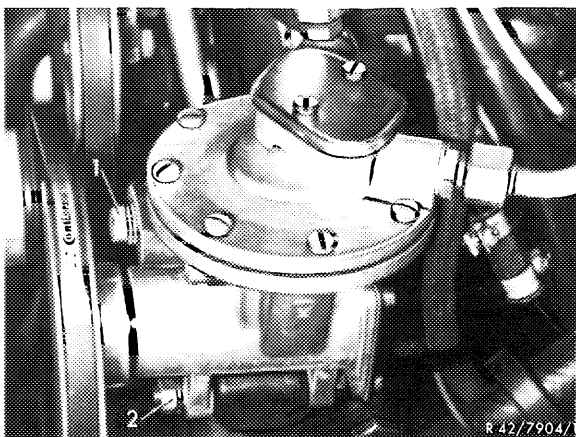
**V-belt D Vacuum Pump**

- Loosen fastening screws (1 and 2).
- Tension V-belt by swivelling vacuum pump in outward direction.
- Retighten fastening screws.

V-belts	Layout	Deflection in mm at 60 N (6 kp) load
A	Alternator – water pump	approx. 10
B	Refrigerant compressor	
C	Power steering pump	approx. 5
D	Vacuum pump	
E	Air pump	approx. 10

Note

The V-belts are tensioned correctly if they just yield elastically to strong thumb pressure.

Belt drive model year 1975

- | | |
|--------------------------|-----------------------|
| 1 Crankshaft | 5 Tensioning roller |
| 2 Water pump | 6 Power steering pump |
| 3 Alternator | 7 Air pump |
| 4 Refrigerant compressor | 8 Vacuum pump |

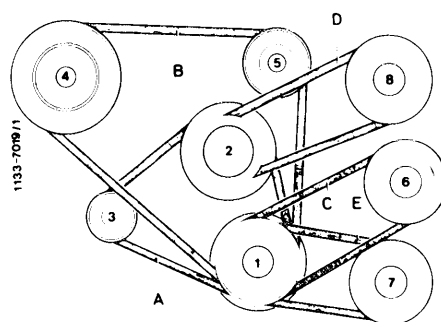

V-belt A Alternator – Water Pump

- Loosen nut (4) of fastening screw (3) and nut (1) of tensioning screw (2).
- Tension V-belt with tensioning screw (2) and tighten nut (1).
- Tighten nut (4) of fastening screw (3).

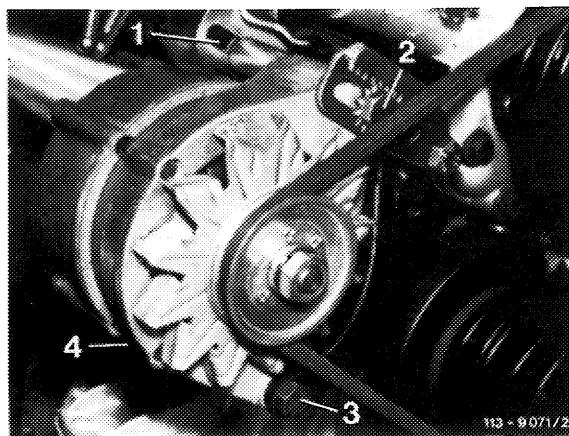

V-belt B Refrigerant Compressor

- Loosen fastening screw (1).
- Tension V-belt by swivelling tensioning roller (2).
- Tighten fastening screw.

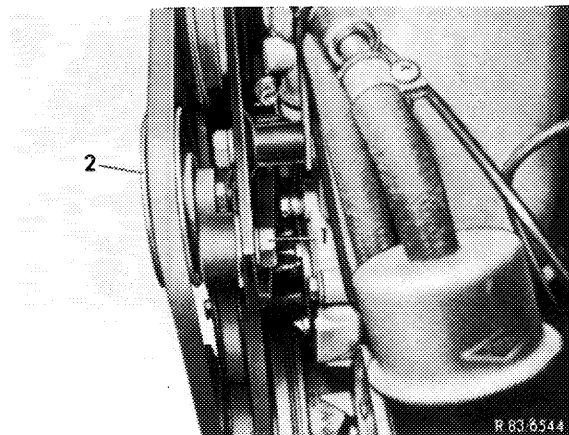

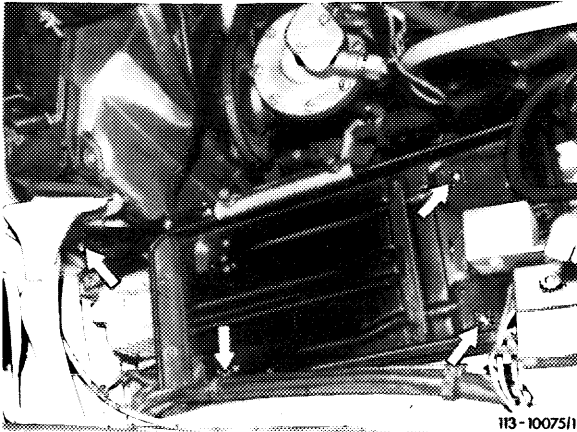

113-10075/1

For retensioning V-belts C and E, pull away charcoal canister in upward direction, as well as remove and install battery carrier (arrows show fastening points of battery carrier).

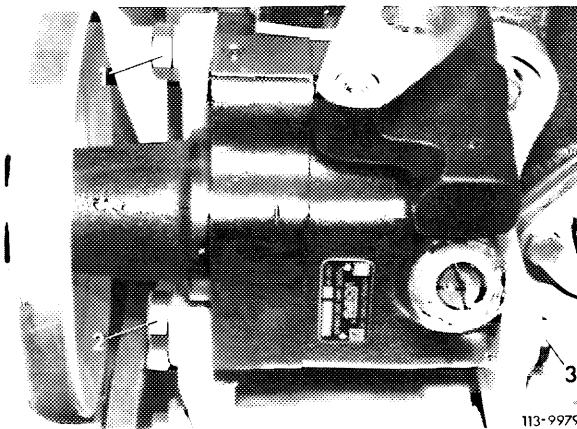

113-9979

V-belt C Power Steering Pump

- Loosen fastening screw (1, 2 and 3).

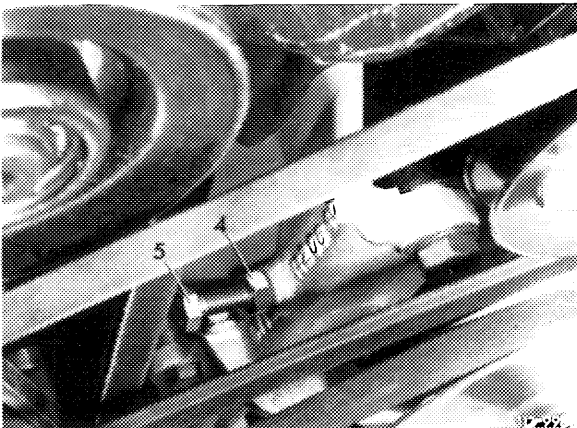

- Loosen counter-nut (4) at rear of combination carrier and tension V-belt by means of tensioning screw (5).

- Tighten counter-nut as well as fastening screws.

Attention! Make sure of required clearance for supply line toward power steering pump.

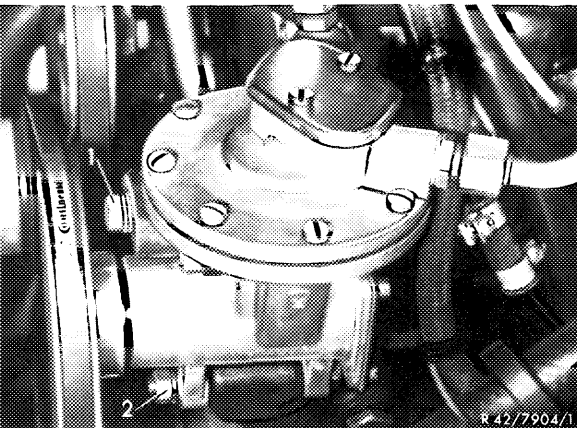

42/7904/1

V-belt D Vacuum Pump

- Loosen fastening screws (1 and 2).
- Tension V-belt by swivelling vacuum pump in outward direction.
- Retighten fastening screws.

V-belt E Air Pump

- Loosen fastening screws (1, 2 and 3).
- Tension V-belt with tensioning nut (4).
- Tighten fastening screws.

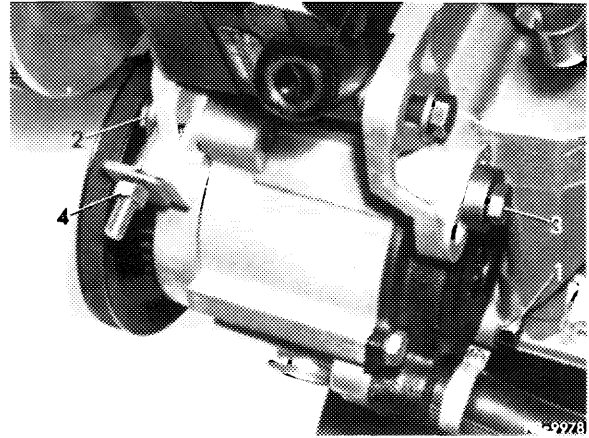
**Belt drive
model year 1976**

- | | |
|--------------------------|-----------------------|
| 1 Crankshaft | 5 Tensioning roller |
| 2 Water pump | 6 Power steering pump |
| 3 Alternator | 7 Air pump |
| 4 Refrigerant compressor | |

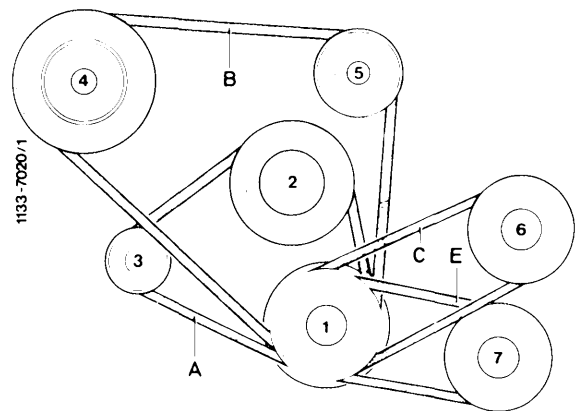

With the introduction of the step-type tandem master cylinder starting model year 1976, the vacuum pump is eliminated. This permits access to power steering pump (6) and air pump (7) without removing battery carrier.

For tensioning V-belts proceed similar to model year 1975.

V-belts	Layout	Deflection in mm at 60 N(6 kp) load
A	Alternator – water pump	approx. 10
B	Refrigerant compressor	
C	Air Pump	
D	Power steering pump	approx. 5

Note

The V-belts are tensioned correctly if they just yield elastically to strong thumb pressure.

- | | |
|--------------------------|-----------------------|
| 1 Crankshaft | 5 Tensioning roller |
| 2 Water pump | 6 Power steering pump |
| 3 Alternator | 7 Air pump |
| 4 Refrigerant compressor | |

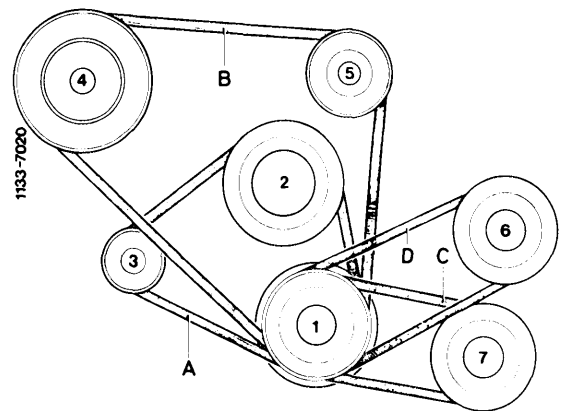

V-belt A Alternator – Water Pump

- Loosen nut (4) of fastening screw (3) and nut (1) of tensioning screw (2).
- Tension V-belt with tensioning screw (2) and tighten nut (1).
- Tighten nut (4) of fastening screw (3).

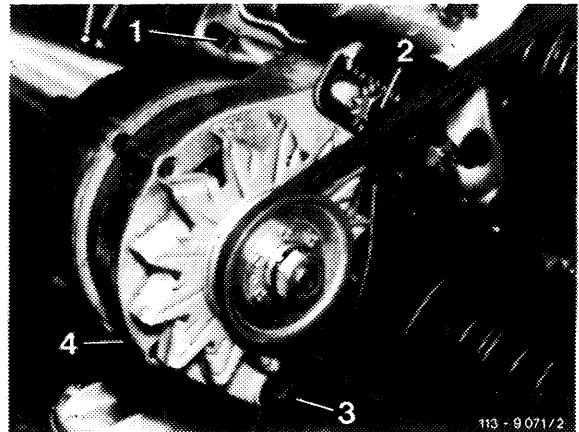

V-belt B Refrigerant Compressor

- Loosen fastening screw (1).
- Tension V-belt by swivelling tensioning roller (2).
- Tighten fastening screw.

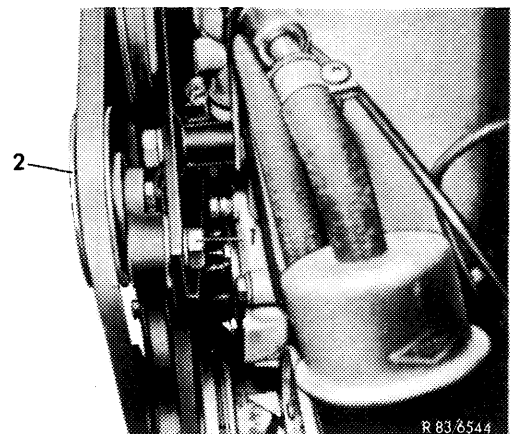

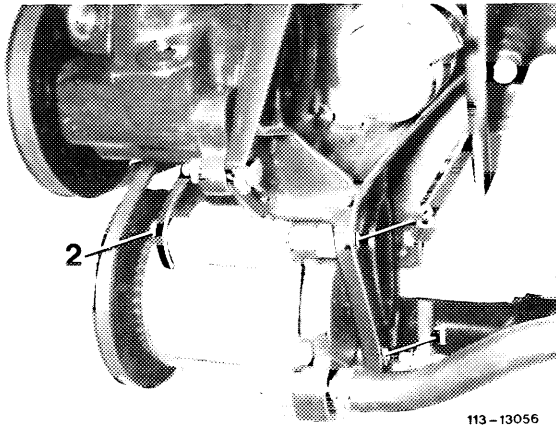

113-13056

V-belt C Air Pump

- Loosen fastening screws (2 and 3) as well as nut (1).

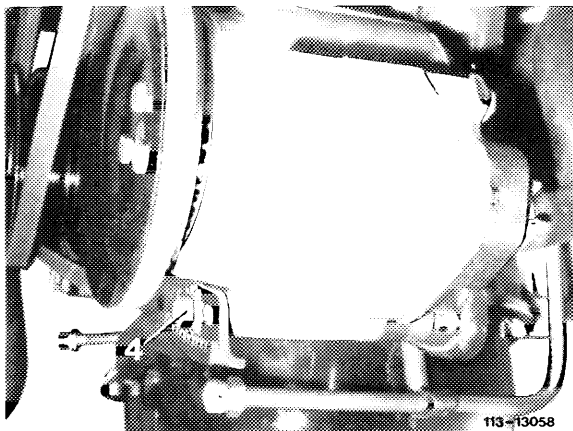

113-13058

- Tension V-belt with tensioning screw (4).
- Tighten nut (1) and fastening screws (2 and 3).

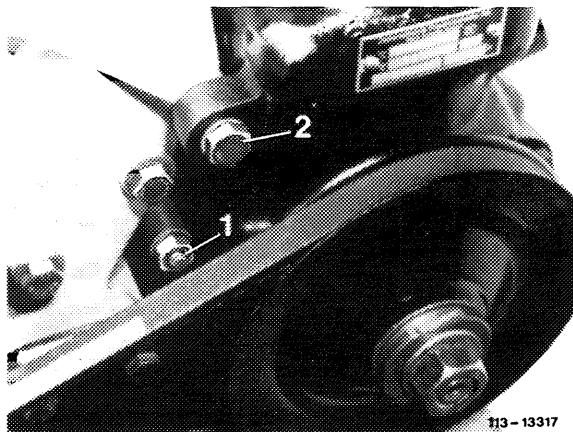

113-13317

V-belt D Alternator

- Loosen screw (2) as well as nuts (1 and 3).

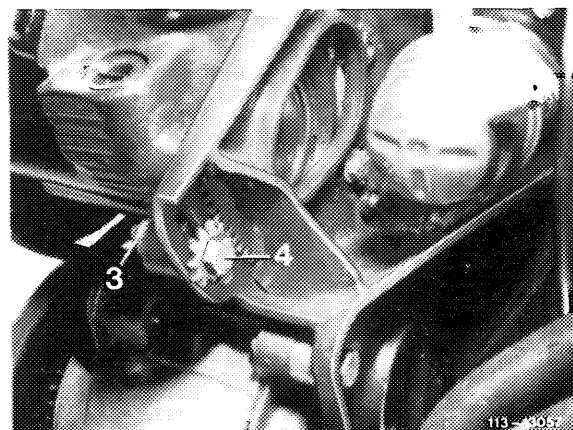

113-13057

- Tension V-belt with tensioning screw (4).
- Tighten nuts (3 and 1) as well as screw (2).

V-belt	Layout	Deflection in mm at 60 N (6 kpm) load
A	Air compressor — air suspension	
B	Water pump — power steering pump	approx. 10
C	Alternator	
D	Refrigerant compressor	approx. 5
E	Air pump	approx. 10

Note

The V-belts are tensioned correctly if they just yield elastically to strong thumb pressure.

Belt drive model year 1974

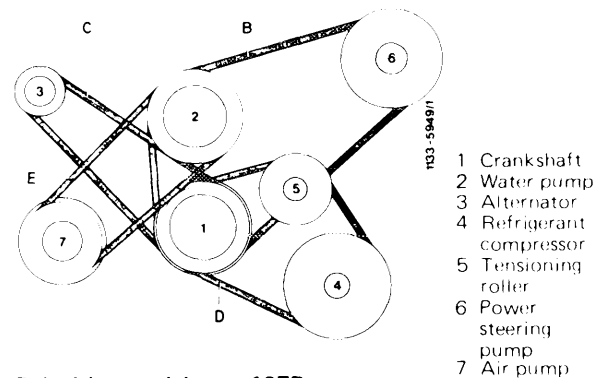

Belt drive up to model year 1973

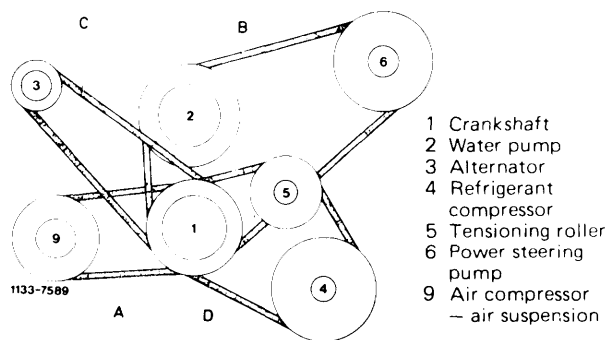

Belt drive model year 1975

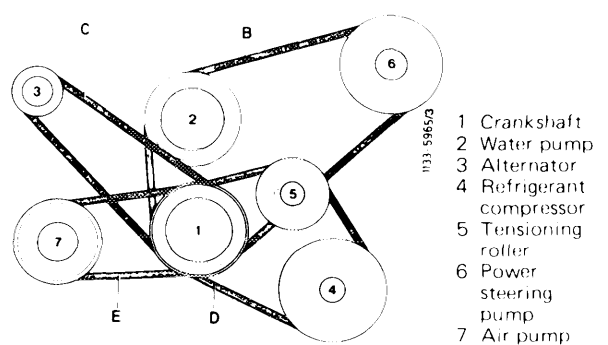

V-belt A Air Compressor for Air Suspension Model 109

- Loosen the nuts of the four fastening screws (1) and the clip for holding bracket of air lines.
- Insert a screw driver or mandrel into perforated plate (2) and adjust air compressor in outward direction by supporting screw driver on bolt (3).
- Tighten the nuts of fastening screws (1) and clip for air lines.

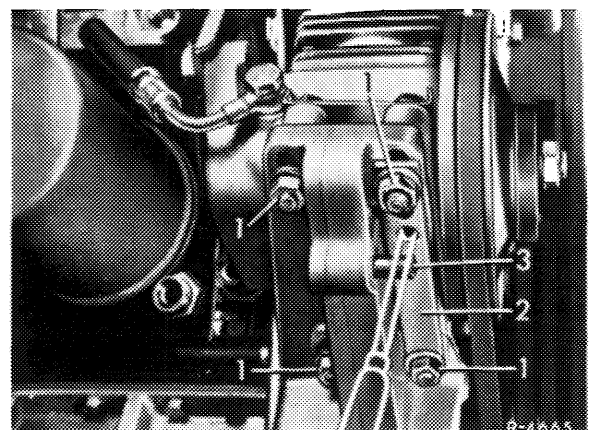

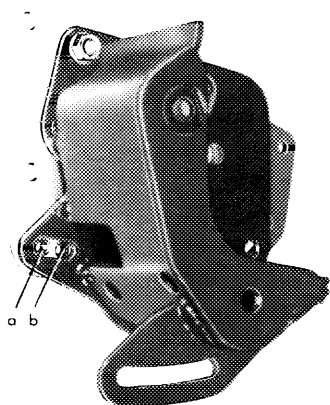
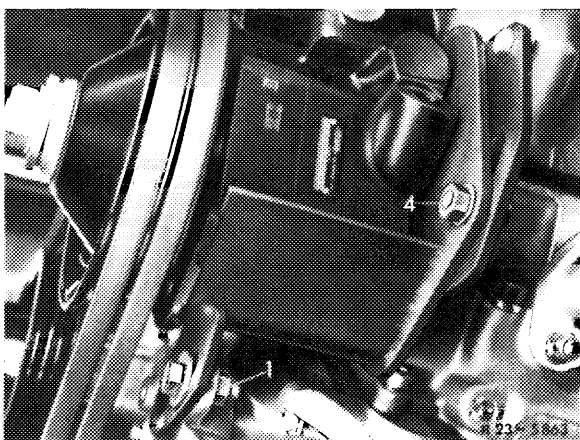
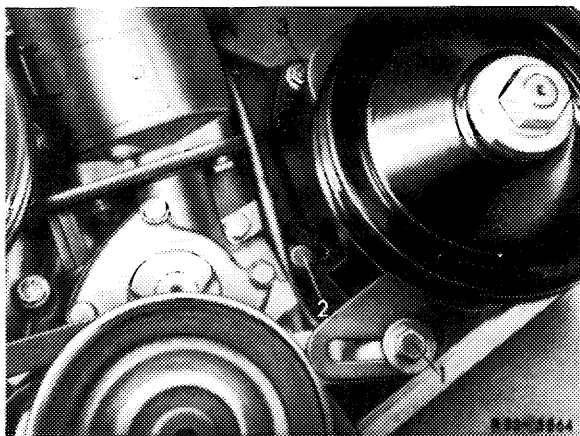

R 13/7228

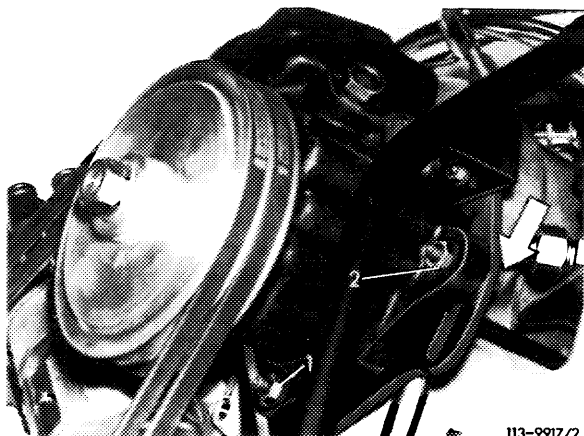

113-9917/2

V-belt B Water Pump – Power Steering Pump

(with power steering pump VT 27)

Up to including model year 1974

- Loosen fastening screws (1, 2 and 4).
- Loosen fastening screw 3 (pivot) only slightly.
- Tension V-belt by swivelling power steering pump outwards.
- Tighten fastening screws.

Attention! If adjustments can no longer be made at fastening screw (1), change fastening screw (2) from tapped hole "a" into tapped hole "b".

When renewing V-belts, put fastening screw (2) back into tapped hole "a".

V-belt B Water Pump – Power Steering Pump

(with power steering pump VT 49 or ZF)

Starting model year 1975

- Loosen fastening screws (1 and 2).
- Loosen fastening screw (3, fig. page 756.55/3) only slightly.
- Tension V-belt by swivelling power steering pump upwards or by turning on hexagon of toothed lock washer (arrow).

- Tighten fastening screws (1, 2 and 3).

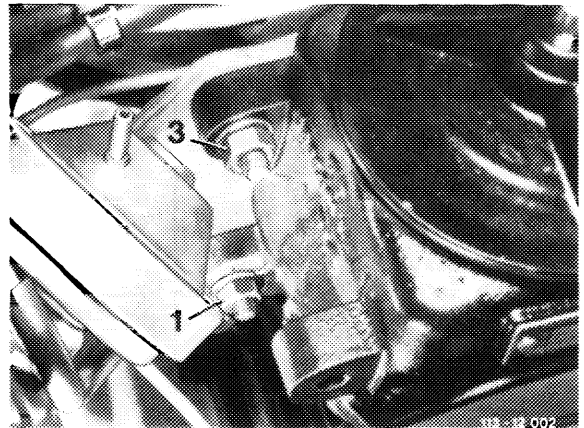

V-belt C Alternator
1st version

- Loosen counter nut (5) and fastening screws (6 and 8).
- Tension V-belt with tensioning nut (7).
- Lock tensioning nut and tighten fastening screws.

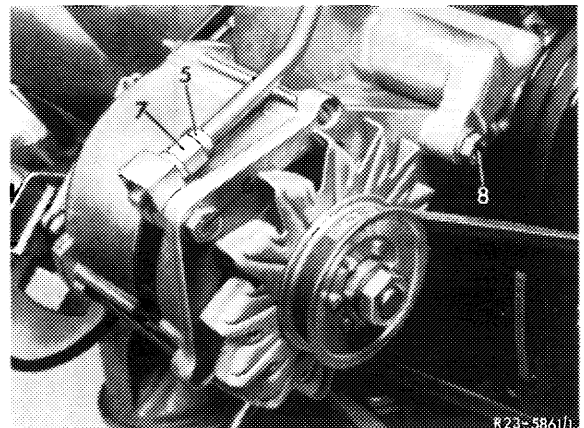

V-belt C Alternator
2nd version

- Loosen fastening screw (1) and nut (2).
- Tension V-belt with tensioning screw (3).
- Tighten nut and fastening screw.

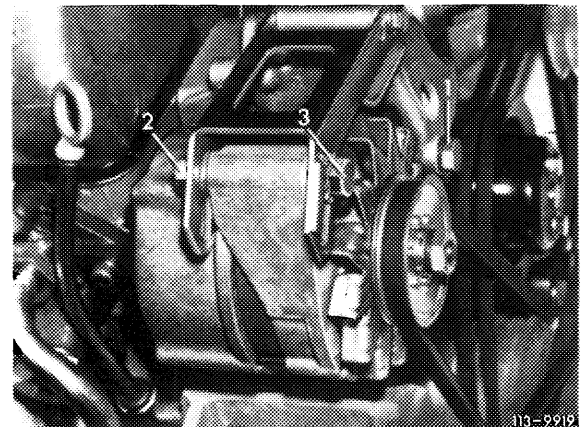

V-belt D Refrigerant Compressor

- Loosen fastening screw (9) of tensioning roller (8).
- Tension V-belt by swivelling tensioning roller.
- Tighten fastening screw.

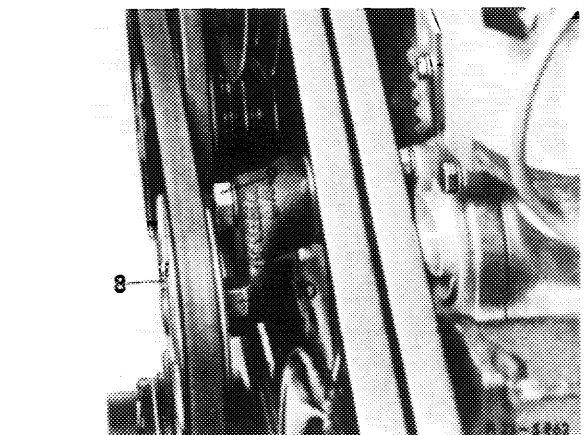

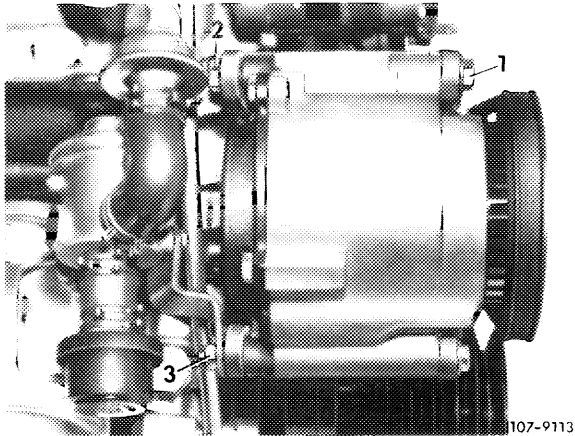
**V-belt E Air Pump**

Model year 1974

- Loosen fastening screws (1 and 2) as well as nut of fastening screw (3, pivot).
- Push air pump outwards until V-belt is tight.
- Tighten fastening screws.

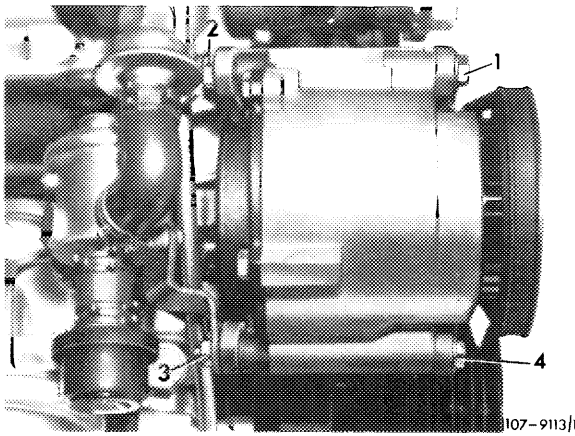
**V-belt E Air Pump**

Starting model year 1975

- Loosen fastening screws (1, 2 and 3).
- Push air pump outwards until V-belt is tight.
- Tighten fastening screws.

Engines 615 616 617
Model year 1972 to 1976

V-belt	Layout	Deflection in mm at 60 N (6 kp) load
A	Alternator – water pump	approx. 10
B	Refrigerant compressor	
C	Power steering pump	approx. 5

Note

The V-belts are tensioned correctly if they just yield elastically to strong thumb pressure.

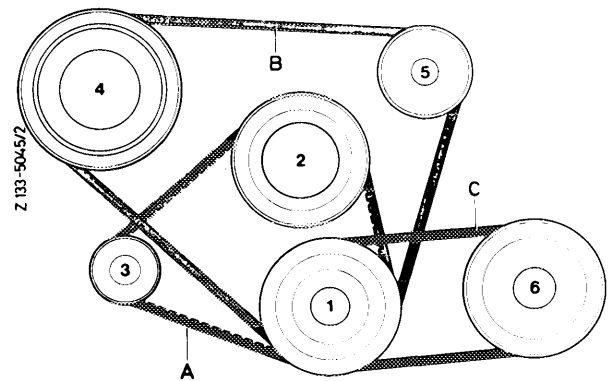

- | | |
|--------------|--------------------------|
| 1 Crankshaft | 4 Refrigerant compressor |
| 2 Water pump | 5 Tensioning roller |
| 3 Alternator | 6 Power steering pump |

V-belt A Alternator – Water Pump
Up to model year 1973

- Loosen counternut (1) and fastening screw (2).
- Tension V-belt with tensioning nut (3).
- Counterlock tensioning nut and tighten fastening screw.

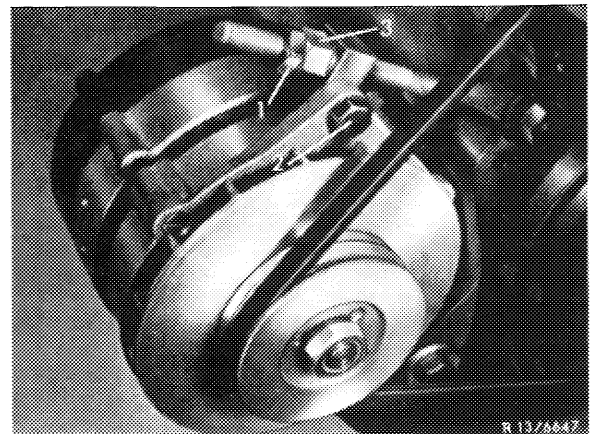

V-belt A Alternator – Water Pump
Starting model year 1974

- Loosen nut (4) of fastening screw (3) and nut (1) of tensioning screw (2).
- Tension V-belt with tensioning screw (2) and tighten nut (1).
- Tighten nut (4) of fastening screw (3).

