

Test values

Thickness of brake pad (lining backup plate and lining)	front	15
	rear	
Thickness of lining backup plate	front	5
	rear	
Permitted wear¹⁾ of brake lining up to a lining thickness of	front	2
	rear	

¹⁾ Within scope of maintenance jobs, replace brake linings when the distance between the eye of the lining backup plate and the cross spring or lining holding spring amounts to approx. 3 mm.

In the event of aggravated operating conditions or increased demands, such as energetic sports-style driving, trailer operation etc., the thickness of the brake pad lining on front axle may require checking in shorter intervals.

Tightening torque	Nm	(kpm)
Spherical collar screws for fastening rims	100	(10)

Conventional tools

Impact wrench, adjustable tightening torque	e.g. made by Atlas-Copco, D-7250 Leonberg, Type LMS 24 HR-01
Hexagon socket wrench insert 17 mm for impact wrench (OD max. 26.5 mm)	e.g. made by Hazet, D-5630 Remscheid, no. 900 S–17
Torque wrench, automatically releasing	e.g. made by Herder, D-5650 Solingen, no. 7562/1

- Remove ornamental wheel trim on steel rims.
- Loosen spherical collar screws crosswise and unscrew.
- Remove rims.

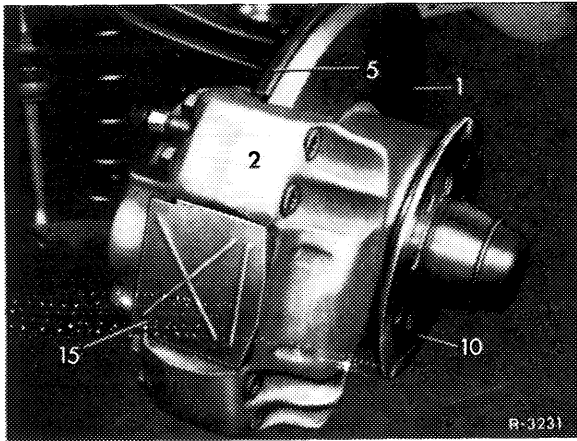

- Remove inspection hole cover plate (15) (installed on vehicles with solid brake discs and calipers with 57 mm piston dia.).

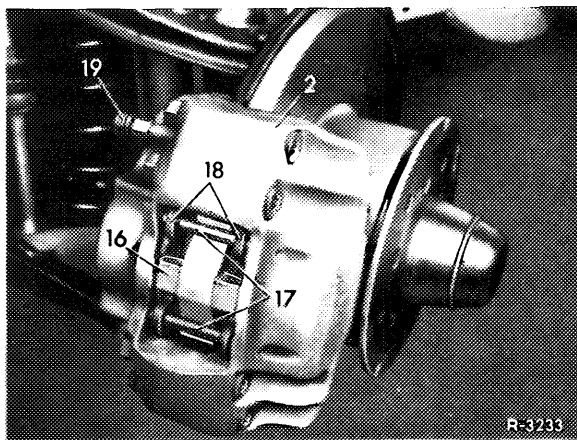

- Check brake pads visually for wear.
- On Teves (ATE) caliper, the eyes of the lining backup plate (18) should not rest against cross spring (16).

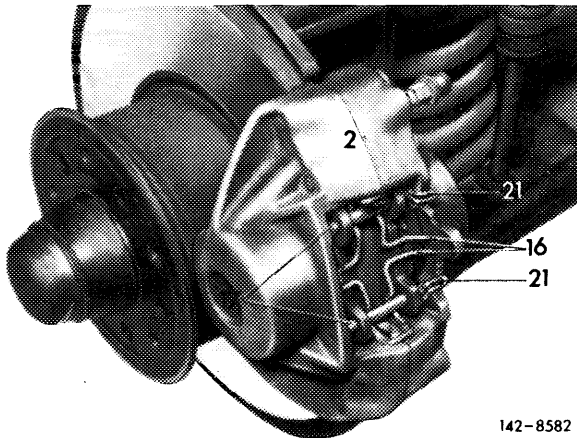

- On Bendix (BX) caliper, the eyes of the lining backup plate should not rest against lining holding spring.

Note: If eyes of lining backup plate are in contact, or if the distance from cross spring or lining holding spring is only slight, brake pads must be renewed.

When new, the distance between the eye and cross spring or lining holding spring amounts to 8 mm.

- Install cover plate, if removed.

16 Lining – holding spring

- Mount wheels, while tightening spherical collar screws crosswise in steps.
- Spherical collar screws can be tightened up to approx. 3/4 of specified tightening torque by means of impact wrench. Then tighten screws manually with torque wrench.

Note: When using impact wrenches on light-alloy rims, the OD of the socket wrench insert may amount to max. 26.5 mm, since otherwise the socket wrench insert will damage the wheel hub.

Make sure that the pertinent spherical collar screws are used for the respective steel and light-alloy rims.

Observe specified tightening torque.

- Mount ornamental wheel trim to steel rims.

