

01-418 Facing cylinder head parting surface

Data

Total height of cylinder head	84.8–85.0	
Minimum height upon machining	84.0	
Permissible unevenness of parting surfaces	in longitudinal direction	0.08
	in transverse direction	0.0
Permissible deviation in parallel of upper parting surface in relation to lower parting surface in longitudinal direction	0.1	
Roughness	0.016	
Test pressure with air under water in bar gauge pressure (atü)	2	

Minimum distance "a" with new valves and new valve seats

Intake + 0.17 to -0.23

Exhaust + 0.12 to -0.28

Max. distance "a" with new valves and machined valve seats

Intake
1.0

Exhaust

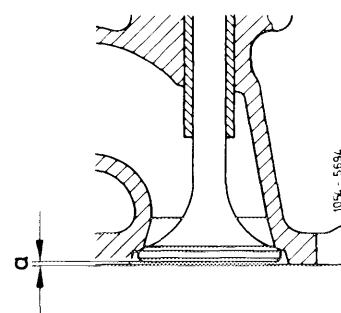

Facing

- 1 Face parting surface of cylinder head.
- 2 Refinish valve seats until minimum distance "a" is attained.
- 3 Check timing (05-215).

