

## 05-440 Removal and installation of guide wheel

### Tightening torques

Nm

Cylinder head cover bolts and capped nuts

5

Ball locating ring in chain tensioner

25

### Special tools

Impact extractor for bearing pin  
(basic unit)

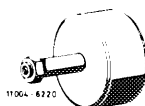

116 589 20 33 00

Chain tensioner holder

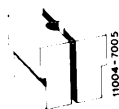

110 589 02 31 00

Wrench socket 10 mm  
1/2" square, 140 mm long

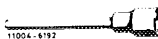

000 589 05 07 00

M 6 x 50 mm bolt for impact extractor



116 589 01 34 00

M 10 x 100 mm bolt for impact extractor



116 589 03 34 00

### Removal

- 1 Mark relation to timing chain and left camshaft sprocket with paint.
- 2 Remove chain tensioner or spring (05-310).
- 3 Remove sliding rail (2) in camshaft housing. This requires knocking out bearing pin with impact extractor (05-340).

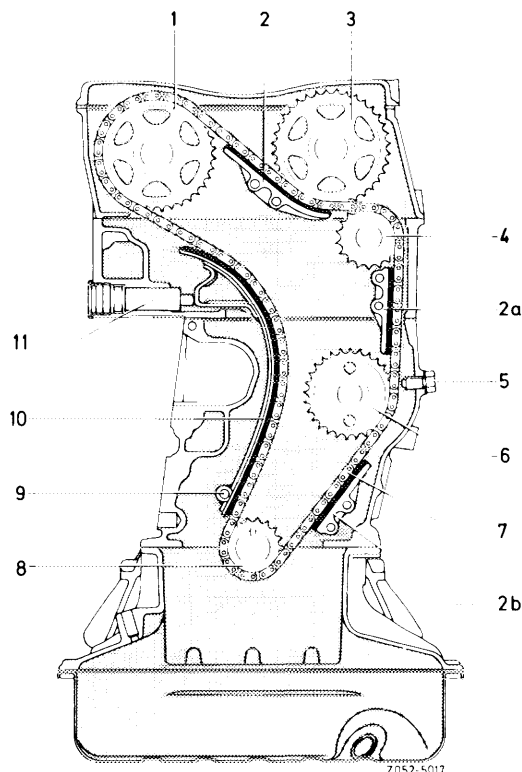

- 1 Exhaust camshaft sprocket
- 2-2b Sliding rail
- 3 Intake camshaft sprocket
- 4 Guide wheel
- 5 Locking screw
- 6 Intermediate wheel
- 7 Timing chain
- 8 Camshaft sprocket
- 9 Tensioning rail bearing pin
- 10 Tensioning rail
- 11 Hydraulic chain tensioner

4 Hold guide wheel with a 5 mm dia. wire hook and knock out bearing pin with an impact extractor (10 mm bolt).

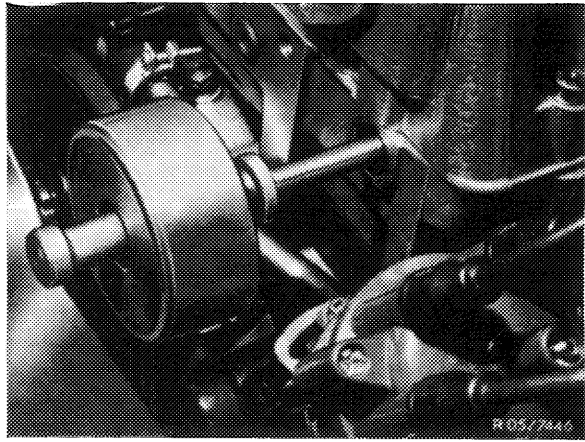

### Installation

---

5 Guide in guide wheel with a 5 mm dia. wire hook, position correctly and knock in bearing pin with an impact extractor.

6 Install sliding rail in camshaft housing, noting marks on timing chain and left camshaft sprocket.

7 Set chain tensioner at assembly position and install, or install spring (05-310).

