

## 07.4–220 Renewing fuel hoses on injection valves

---

### Special tool

---

Clamping device with assembly mandrel



116 589 07 31 00

---

### Conventional tools

---

Side-cutting pliers, soldering gun

---

When replacing fuel hose, put injection valve into clamping device and clamp together with clamping device in a vise.

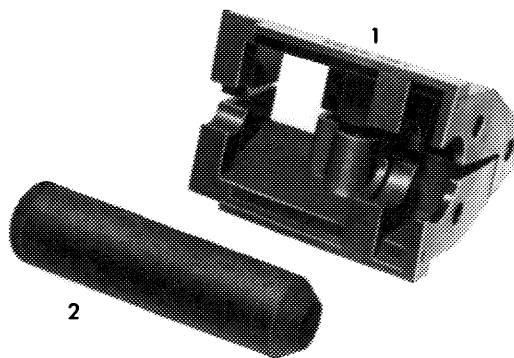

107–10048

#### a) Injection valves former version (hose sleeve 17 mm burnished black)

1 Remove injection valves together with ring line (07.4–215). For easier disassembly, cut fuel hoses of ring line.

Once released, fuel hoses cannot be used again. Always install new fuel hoses.

2 Remove injection valves from ring line.

3 Place injection valve into clamping device and clamp into a vise. Electrical connection should point downwards. Close hose with closing cap.

4 Cut through hose sleeve with a flat file.

5 Insert injection valve into opposite end of clamping device and clamp into vise. Cut hose sleeve with side-cutting pliers and pull-off hose.

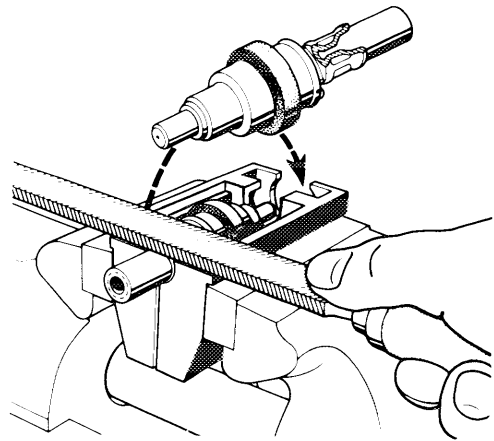

1074 - 5990/1

6 Clean connection. No dirt should enter connection, so that the fuel strainer inside connection is not clogged or damaged.

7 Push new fuel hose from repair kit part no. 000 586 99 07 with assembly mandrel up to stop on injection valve.

For easier assembly, immerse fuel hose into fuel; **do not use oil, grease or other sliding compounds!**

8 Slip one of the beaded hose clips of repair kit over fuel hose up to stop on injection valve and attach. Do not tighten hose clip to limit (distance approx. 2 mm).

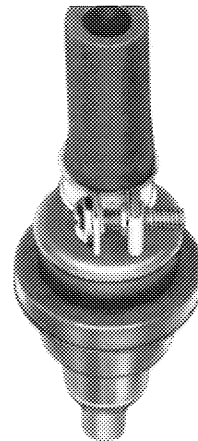

107-9725

9 Slip injection valves with other beaded hose clips from repair kit up to stop on ring line connections and turn in such a manner that the electric connections of the injection valves in installed condition are pointing toward the rear on cylinders 1–7, and toward the front on cylinder 8.

**Attention!**

Do not use hose clips other than those in repair kit. Mount hose clips behind bead and with screw head pointing toward cylinder head cover (distance between ring line and hose clip approx. 3mm). Do not tighten hose clips to limit. Distance approx. 2 mm.

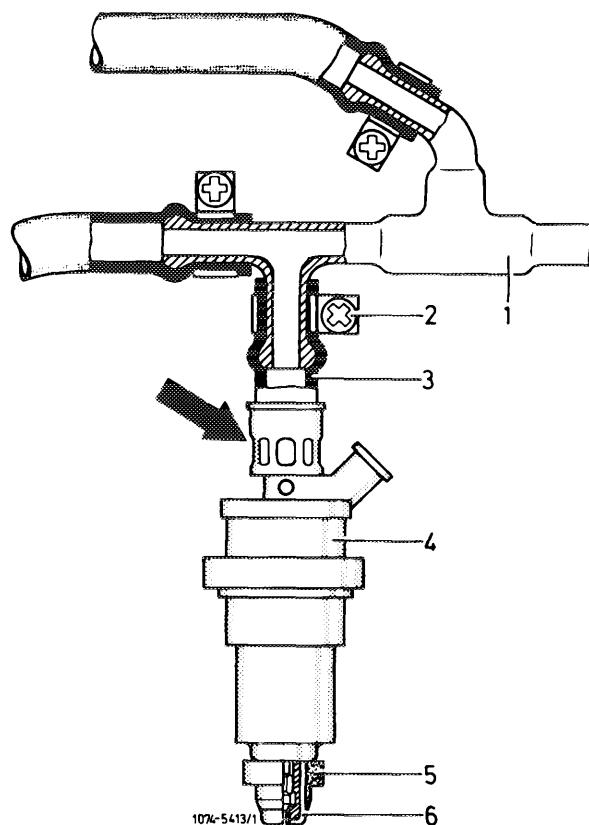

Injection valve with ring line ready for installation

- 1 Ring line
- 2 Hose clip
- 3 Fuel hose
- 4 Injection valve
- 5 Rubber sealing ring
- 6 Sleeve (color code engine 116 yellow, engine 117 blue)

10 Install ring line with injection valves, use new rubber sealing rings part no. 116 078 04 73 or 07 73.

11 Perform leak test immediately upon starting. Check hose connections for leaks, correct assembly and chafing marks with the engine running by moving connecting points manually.

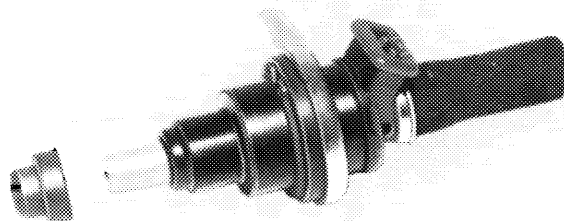

Rubber seal  
Part no. 116 078 04 73

107-9711

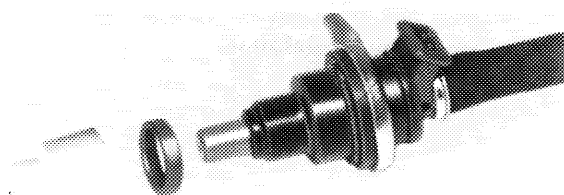

Rubber seal  
Part no. 116 078 07 73

107-9710

**Attention!**

On the following injection valves the repair method cannot be applied:

Injection valves of the old version, identified by the **hose sleeve 17 mm high and chromatised yellow**. Installed on engine 116.

Arrow: hose sleeve chromatised yellow

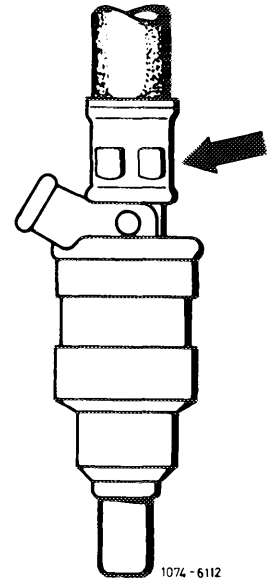

Injection valves with smooth hose sleeves 17 mm high burnished black – Temporarily on engines 116 and 117.

Arrow: smooth hose sleeve burnished black

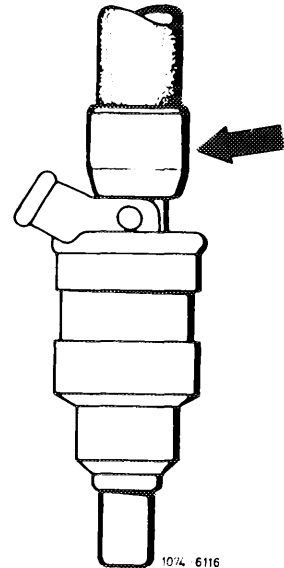

**b) Injection valves with double sealing edge connection (hose sleeve approx. 5 mm)**

1 Remove injection valves together with ring line (07.4-215).

For easier disassembly, cut through fuel hoses of ring line.

Once released, fuel hoses may not be used again. Use new fuel hoses during installation.

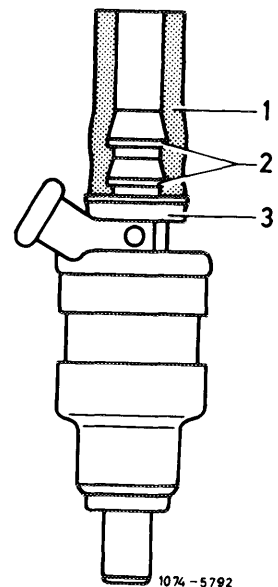

2 Remove injection valves from ring line.

3 Place injection valve into clamping device and clamp into a vise. Electrical connection should point downwards.

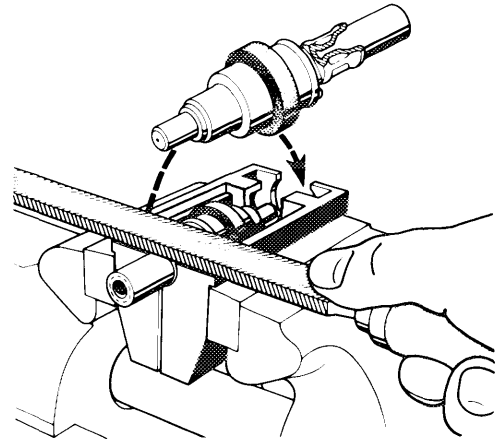

1074 - 5990/1

4 Cut hose sleeve with side-cutting pliers and bend open. Grind side-cutting pliers accordingly.

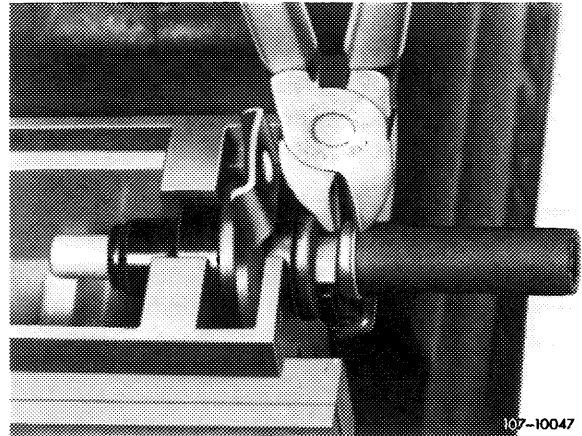

107-10047

5 Loosen fuel hose on injection valve with an electric soldering gun. Cut fuel hose opposite connecting point of electric plug. Move soldering gun back and forth along entire length of connection until fuel hose can be pulled off with pliers.

**Attention!**

Do not damage plastic insulating body on injection valve with soldering gun. To avoid damaging double sealing edge connection, never cut fuel hose with a cutting tool (e.g. a knife). Even minor damage may result in leaks.

6 Clean connection. No dirt should enter connection, so that the fuel strainer in connection is not clogged or damaged.

7 Mount new hose sleeve from repair kit part no. 001 586 00 07 on connection.

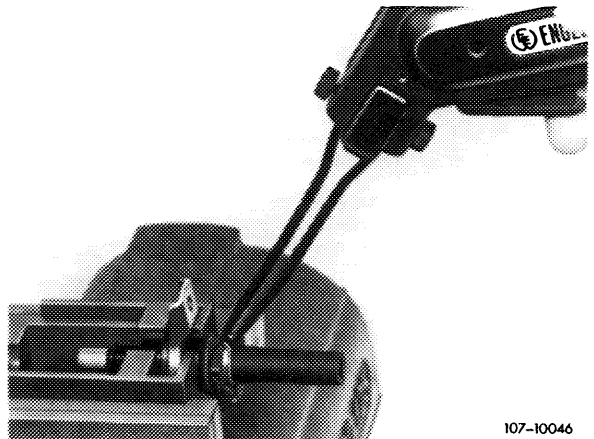

107-10046

8 Push new fuel hose completely on connection by means of an assembly mandrel until hose is perfectly seated in hose sleeve and can no longer be moved.

**Attention!**

On injection valves with double sealing edge connection, no hose clip should be mounted at injection valve. Mount hose clip at ring line end of fuel hose only. Use hose clips from repair kit only.

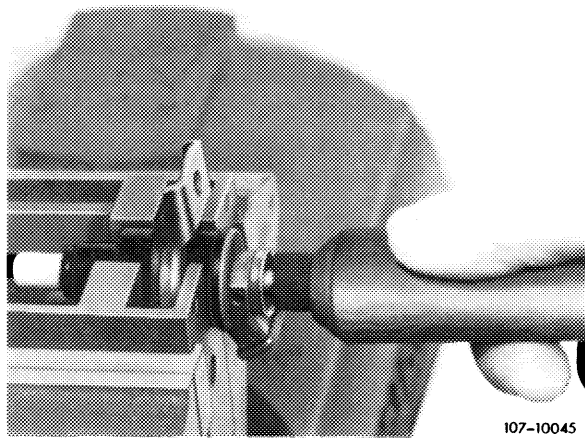

107-10045

9 Slip injection valves with hose clips (for ring line connections only) on ring line and turn in such a manner that the electric connections of the injection valves are pointing toward the rear on cylinders 1–7 and toward the front on cylinder 8.

**Attention!**

Mount hose clips behind bead and with screw head pointing toward cylinder head cover (distance between ring line and hose clip approx. 3mm). Do not tighten hose clips to limit. Distance approx. 2 mm.

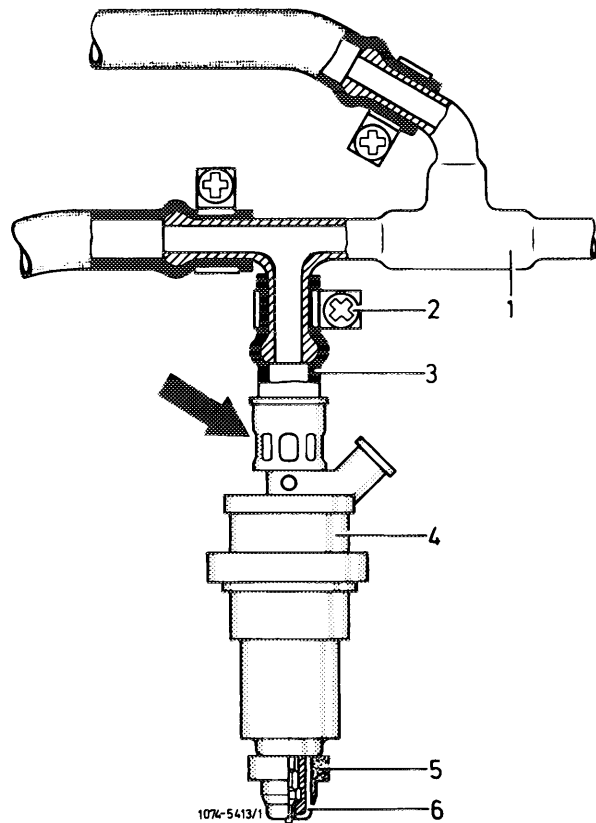

Injection valve with ring line ready for installation

- 1 Ring line
- 2 Hose clip
- 3 Fuel hose
- 4 Injection valve
- 5 Rubber sealing ring
- 6 Sleeve (color code engine 116 yellow, engine 117 blue)

107N-5413/1

10 Insert new rubber sealing rings and install injection valves with ring line.

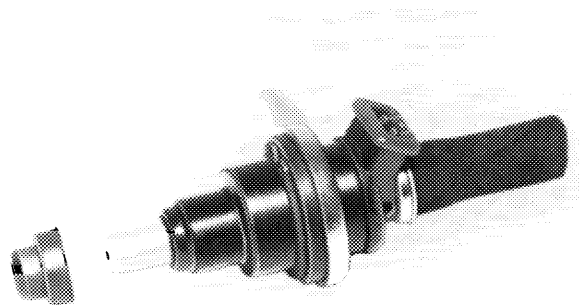

Rubber sealing ring  
Part no. 116 078 04 73

107-971i

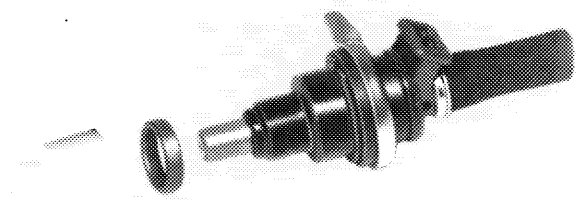

Rubber sealing ring  
Part No. 116 078 07 73

107-9710

11 Perform leak test immediately upon starting.  
Check hose connections for leaks, correct assembly  
and chafing marks with the engine running by moving  
connecting points manually.