

07.4–110 Regulating engine

A. Standard version

Testing and adjusting data

Engine	Idle speed 1/min	Idle speed emission value % CO
116, 117	700–750	1.5–2.5

B. National version J USA

Identification: Information plate in national language on cross member in front of radiator or on cylinder head cover.

Adjust engines according to data of respective emission control information plate.

Engine	Model year	Idle speed 1/min	Idle speed emission value % CO
--------	------------	------------------	--------------------------------

J

Information plate: yellow imprint „Japan“

116, 117	up to 1976	760–800	max 1.5
----------	------------	---------	---------

USA

Information plate: color code black/green.

116	1970/71	750–800	1.0–2.0
117	1972/73	700–800	0.5–2.0
117 Federal emission control (black information plate)	1974		
117 California emission control (green information plate)	1974		max 1.0 with air injection
117	1975		max 1.5 without air injection

Special tools

Digital tester

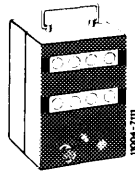

001 589 54 21 00

Connecting cable

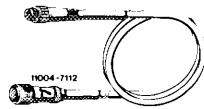

000 589 04 90 00

Oil telethermometer



116 589 27 21 00

Conventional tools

CO measuring instrument, revolution counter, stroboscope, oscilloscope

Note

Do not regulate engine when it is too hot, e.g. immediately following a fast ride or after measuring output on output dynamometer.

Regulation

- 1 Switch off air conditioner or automatic climate control. Move selector lever into position „P“.
- 2 Connect test instruments: CO measuring instrument, revolution counter, stroboscope, oscilloscope, digital tester.
- 3 Evaluate oscilloscope display.
- 4 Check firing point and adjust, if required. Check centrifugal and vacuum ignition adjustment (07.5–500).
- 5 Check intake system for leaks. For this purpose, spray all sealed points with Iso-Oktan DIN 51756 or benzine.

Attention!

Do not use conventional tools for spraying (vapours are dangerous to health). Note inflammability and do not spray on red-hot components or parts of ignition system.

6 Run engine up to operating speed (60–80°C engine oil temperature).

7 Check engine regulating linkage for easy operation and wear. Lubricate all bearing points and ball sockets.

8 Check whether Bowden wire for Tempomat/Cruise Control rests free of tension against regulating lever (arrow). Set with adjusting nut (1 or 18), if required.

1st version

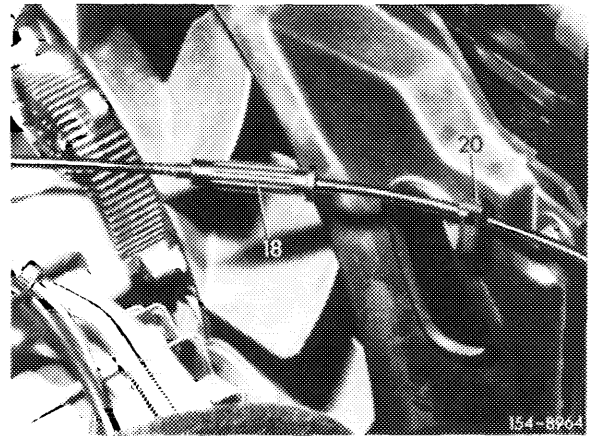

2nd version

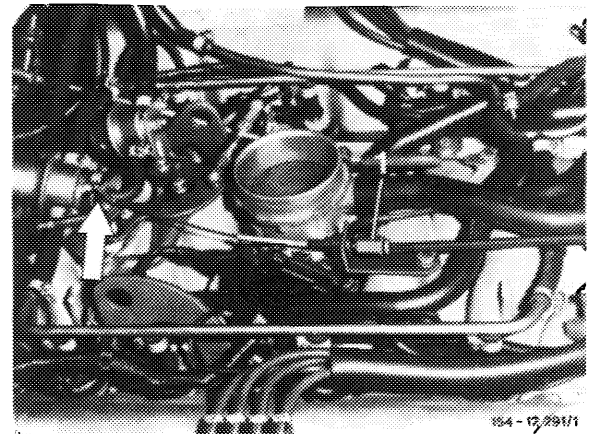

9 Check whether throttle valve rests against idle speed stop. For this purpose, disconnect connecting rod.

10 Check regulating linkage.

a) On vehicles with gate lever

Check whether roller (7) in gate lever (19) rests free of tension against end stop. Adjust with connecting rod (11), if required.

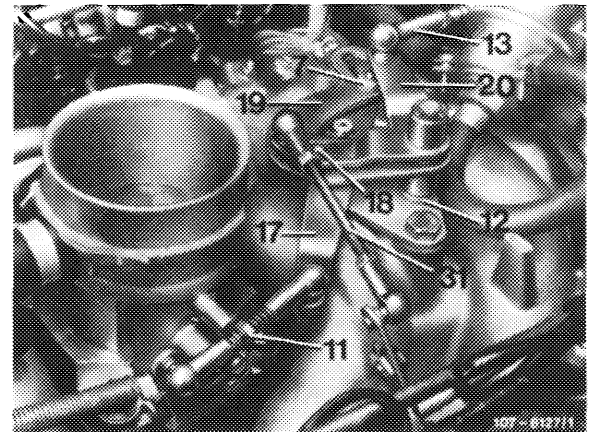

b) On vehicles without gate lever

Check whether regulating lever (14) rests against stop pin (16). Adjust connecting rod (11), if required.

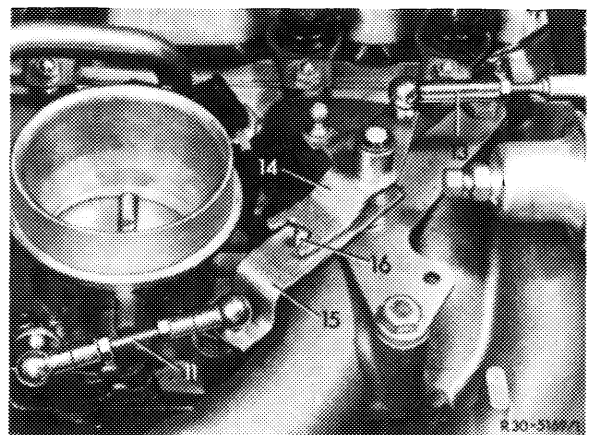

11 Set to specified idle speed by means of idle speed air screw (arrow).

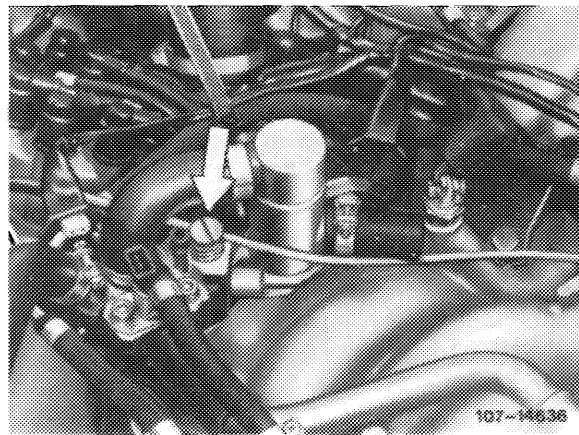

12 Check idle speed emission value.

On vehicles USA version model year 1975 check emission value **without** air injection and adjust, if required.

For this purpose, pull-off plug connection (arrow) of oil temperature switch 17°C at right-hand wheel house and connect to ground. This will cut out the air injection.

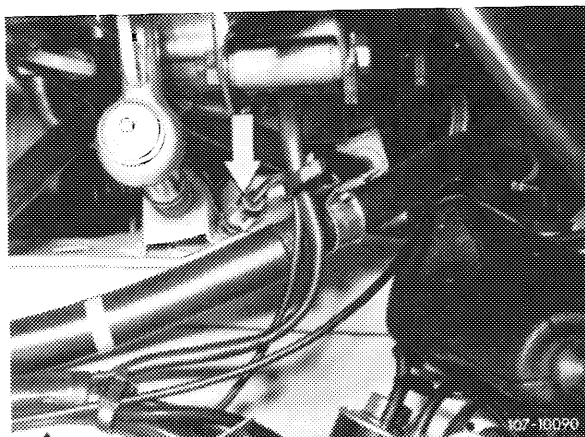

13 Adjust idle speed emission value.

Adjust idle speed emission value by means of adjusting screw (arrow) on control unit.

Turning counterclockwise = leaner
Turning clockwise = richer

On model 107 the control unit is accessible after loosening inside panelling under glove box. On vehicles with right-hand steering the control unit is mounted at the left.

Model 107

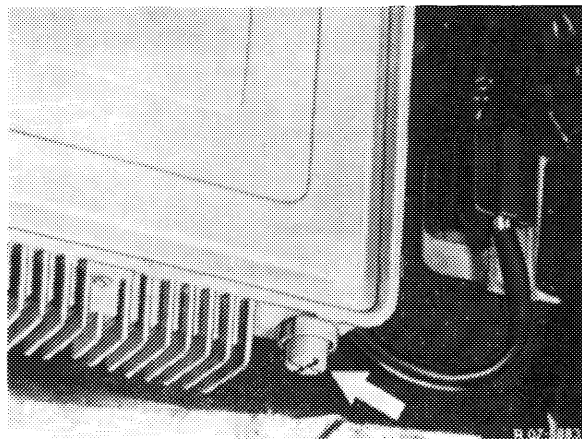

On model 116 the control unit is mounted in legroom at front right. Remove ornamental moulding for adjusting emission value.

On vehicles with right-hand steering the control unit is mounted at the left.

Model 116

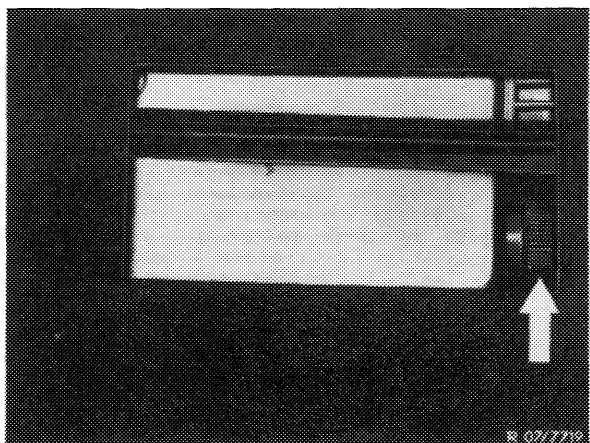

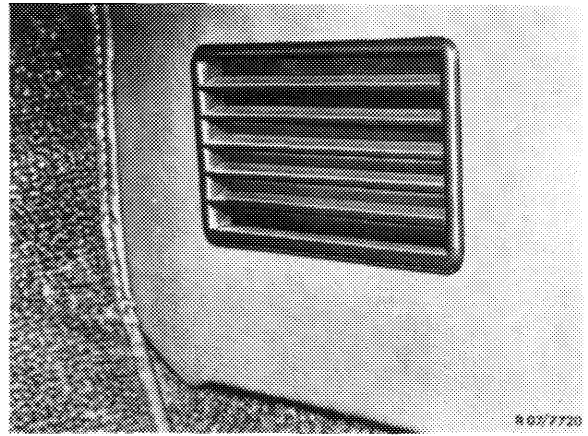

Accelerate for a short moment, check idle speed and idle speed emission value once again and readjust, if required.

On vehicles USA version model year 1975, join plug connection of temperature switch 17°C. Check idle speed emission value once again (air injection operating). The idle speed emission value should be below the value previously adjusted.

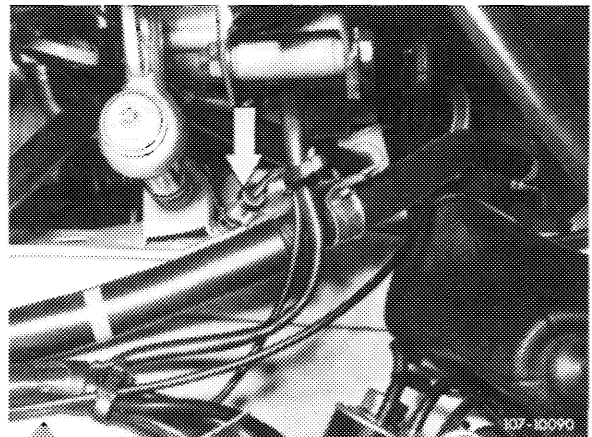

14 Mount air filter. Check idle speed and idle speed emission value once again and adjust, if required.

15 Set selector lever to driving position, switch-on air conditioner or automatic climate control, turn power steering to full lock with engine running. Adjust speed, if required.