



05–320 Renewing timing chain

Valve clearance	with engine cold (approx. 20 °C)	with engine warm (60 °C ± 15 °C)
Intake	0.10 ¹⁾	0.15 ¹⁾
Exhaust	0.20	0.25

¹⁾ 0.05 mm higher during lasting outside temperatures below –20 °C.

Tightening torques	Nm
Fastening screw for camshaft sprocket	100
Bolts for cylinder head cover	3
Valve adjusting screws	20–40

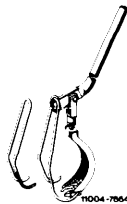
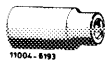
Special tools

Valve spring depressor		123 589 03 61 00
Socket 27 mm, 1/2" square for rotating engine		001 589 65 09 00
Square drive socket 1/2", 80 mm long for rotating engine		617 589 00 16 00
Valve adjusting wrench 17 mm		116 589 02 01 00

Note

For repairs, a repair chain with plug link is available.

If only an endless timing chain is available, chain can be split by cutting **both bolts of one link** with a grinding wheel and mounting chain with a plug link.

An endless timing chain can be mounted with timing housing cover removed.

Check sprockets for score marks and pitting.

Repair chain with plug link.

Engine 116: 186 links, part No. 000 997 75 94
 Engine 117: 198 links, part No. 000 997 76 94

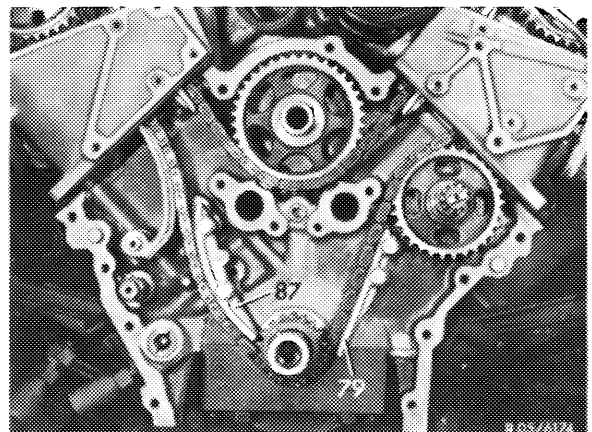

Renewal

- 1 Remove spark plugs.
- 2 Remove rocker arms on righthand camshaft (05-230).

Attention!

Install rocker arms again at the same spot.

- 3 Remove chain tensioner (05-310).

- 4 Cover chain box with rags and cut timing chain with a chain cutter or grind up both bolts of one link.

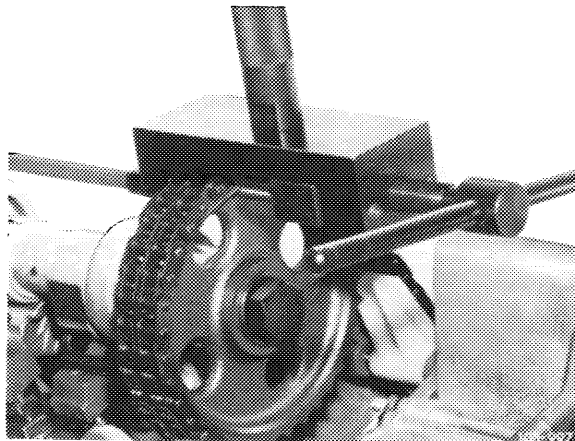

- 5 Attach new timing chain with a plug link to old timing chain while removing cut-up link.

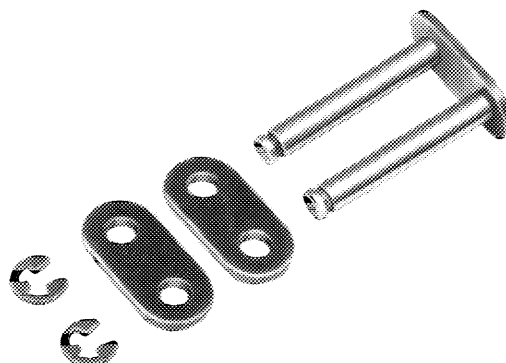

6 Rotate crankshaft with tool combination slowly in direction of rotation of engine while simultaneously pulling up the old chain until the plug link comes to rest against top spot of righthand camshaft sprocket.

Attention!

While turning on both camshaft sprockets, the timing chain should always remain in mesh.

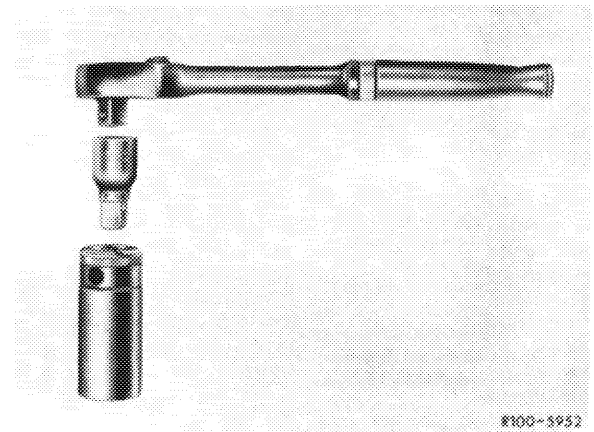

7 Disconnect old timing chain and connect the ends of the new timing chain with a plug link.

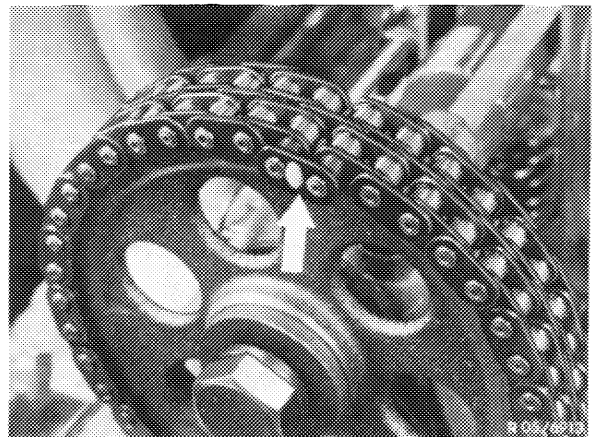

8 Place engine on ignition TDC of 1st cylinder.

Check timing, if the markings (arrow) are not accurately in alignment (05-215).

9 Complete engine assembly.

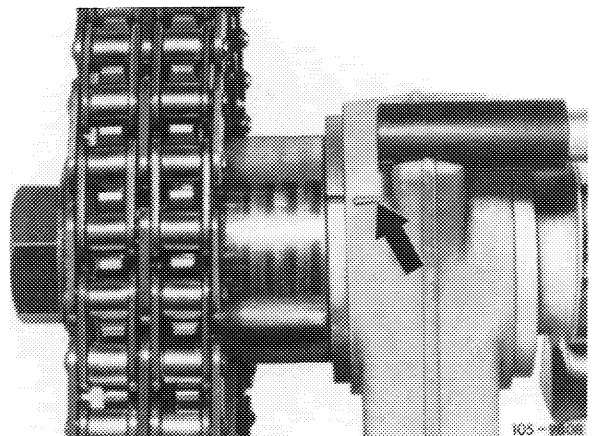

- 1 Screw M 14 x 1.5 x 40
- 2 Spring washer B 14
- 3 Washer
- 4 Camshaft sprocket
- 5 Double roller chain
- 6 Plug link for repairs
- 7 Screw M 8
- 8 Spring washer
- 9 Chain tensioner
- 10 Gasket
- 11 Closing plug M 14 x 1.5
- 12 Sealing ring
- 13 Bearing pin
- 14 Tensioning rail
- 15 Lining
- 16 Guide wheel
- 17 Screw M 8 x 38
- 18 Spring washer
- 19 Slide rail, curved
- 20 Drive sprocket ignition distributor
- 21 Bearing pin
- 22 Slide rail
- 23 Single roller chain oil pump
- 24 Clamp
- 25 Lock washer
- 26 Slide rail in cylinder crankcase
- 27 Tensioning spring
- 28 Washer
- 29 Screw M 8 x 30

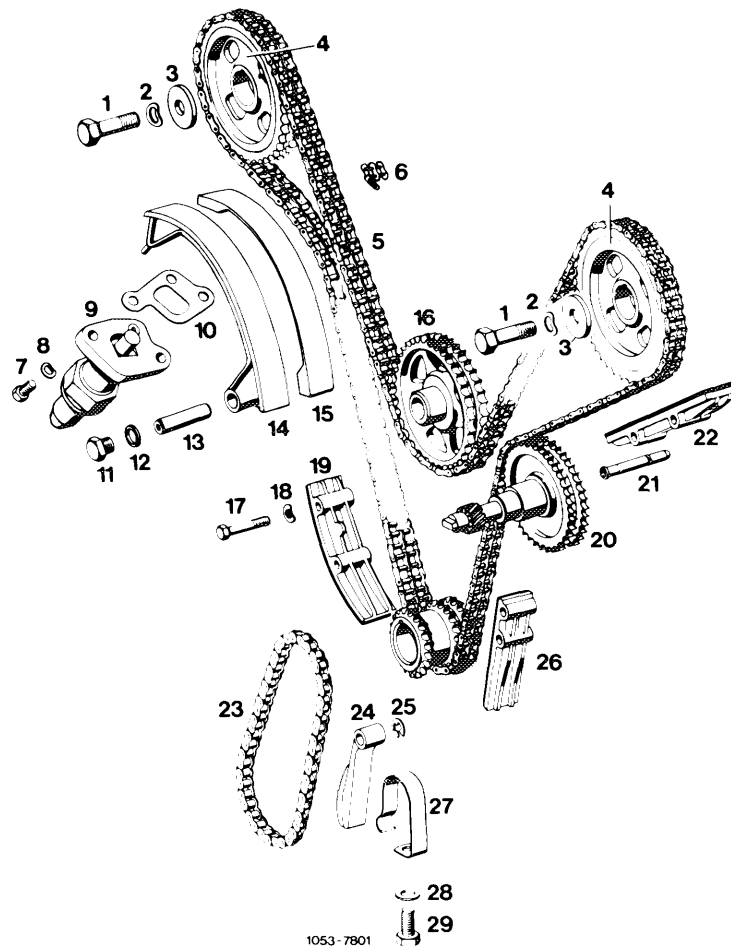

1053-7801