

05–212 Renewal of threaded bushing with valve adjusting screw

Valve clearance	with engine cold (approx. 20 °C)	with engine warm (60 °C ± 15 °C)
Intake	0.10 ¹⁾	0.15 ¹⁾
Exhaust	0.20	0.25

¹⁾ 0.05 mm higher during lasting outside temperatures below –20 °C.

Tightening torques	Nm
Bolts for cylinder head cover	3
Threaded bushing in cylinder head	80
Valve adjusting screw	20–40

Special tools

Remover and installer
for rocker arms

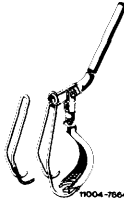

123 589 03 61 00

Valve adjusting wrench 17 mm



116 589 02 01 00

Contact handle for rotating engine
(component of compression meter
001 589 46 21 00)

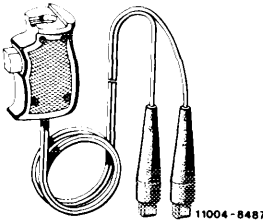

001 589 46 21 08

Note

If the torque of the valve adjusting screw is below 20 Nm, renew valve adjusting screw (2) or threaded bushing (1) with valve adjusting screw (2).

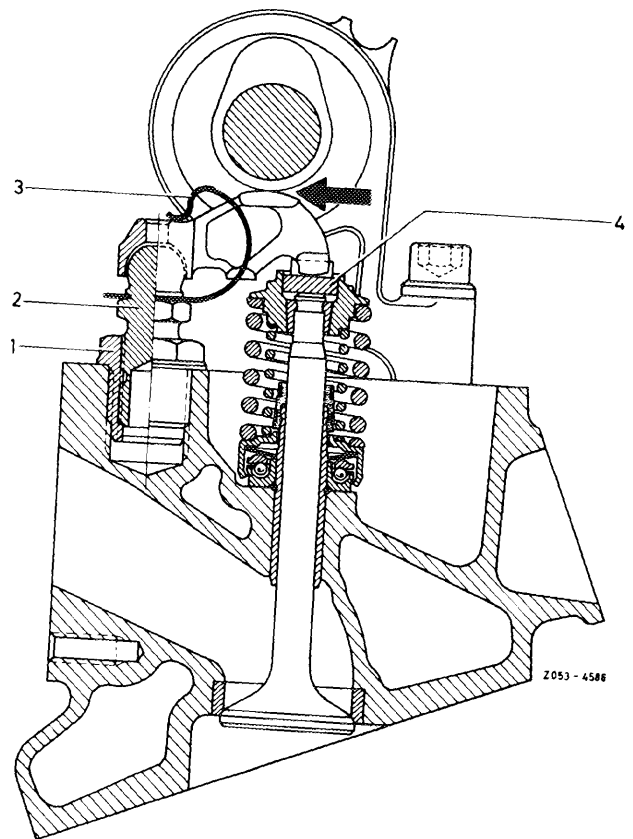

1 Remove tensioning springs.

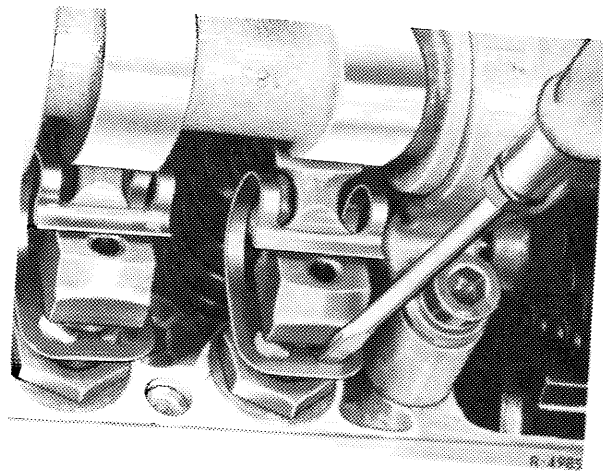

2 Remove rocker arm (05-230).

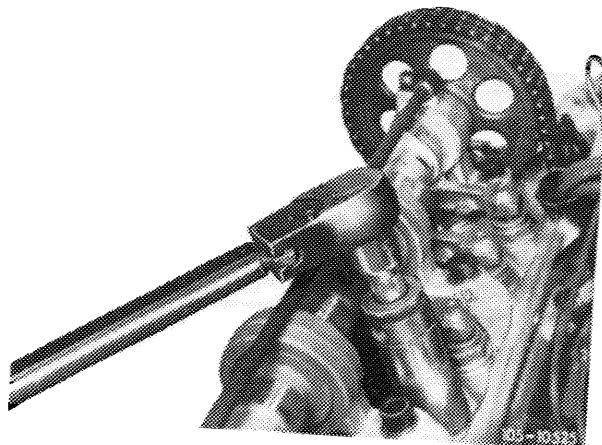

3 Unscrew threaded bushing.

4 Coat new threaded bushing with valve adjusting screw on threads with tallow, screw-in and tighten to 80 Nm.

5 Coat bearing surface of rocker arm with oil and install rocker arm.

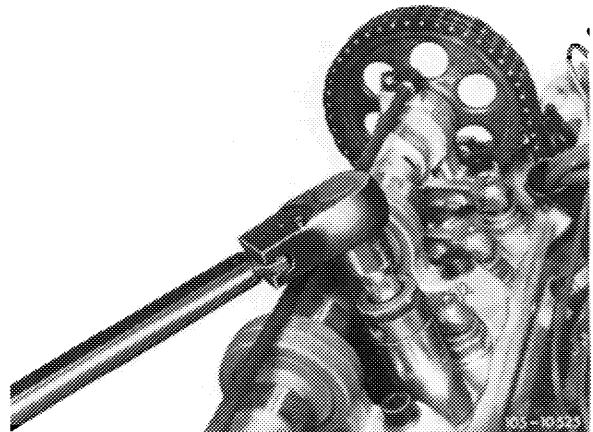

6 Push tensioning spring into ring groove of valve adjusting screw.

Attention!

Rocker arms and tensioning springs of engines 116 and 117 and rocker arms and tensioning springs of engine 110 may not be interchanged.

The center tensioning spring (arrows) can be used for engines 116, 117 and 110.

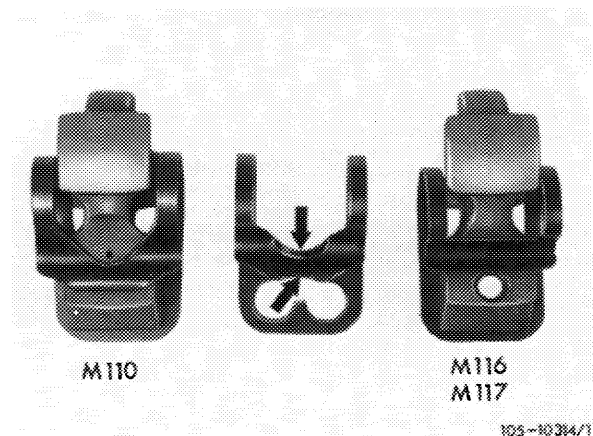

7 Adjust valve clearance (05–210).