

03–327 Renewing rear crankshaft radial sealing ring

Necked-down bolts for flywheel and driven plates on crankshaft

Necked-down bolts, part no.	116 032 02 71	
Threads D	M 12 x 1.5	
Necked-down bolt dia. d	when new	9.8–0.2
	minimum dia.	9.3
Length L	23	

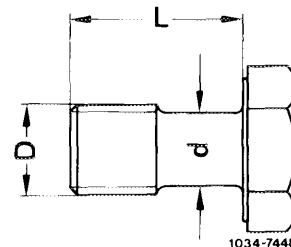

Tightening torque

Flywheel or driven plate on crankshaft	initial torque	30–40 Nm
	angle of rotation torque	90–100°

Special tool

Installer for radial sealing ring
with end cover mounted

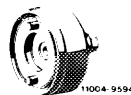

117 589 00 43 00

Note

On a crankshaft with scored running surface, install a radial sealing ring of pertinent repair stage with sealing lip offset in inward direction.

Radial sealing ring	standard	width = 15 mm
Radial sealing ring	repair stage	width = 10.5 mm

The running surface for rear radial sealing ring on crankshaft is hardened and ground.

Renewing

1 Push-out radial sealing ring by means of a screw driver.

Attention!

Do not damage crankshaft and mounting bore for radial sealing ring.

2 Check running surface on crankshaft.

- 3 Screw insertion bushing to crankshaft.
- 4 Fill radial sealing ring between dust lip and sealing lip with longterm grease according to sheet 266.2 of Specifications for service products.
- 5 Slip radial sealing ring on insertion bushing.

6 Push radial sealing ring up to stop into cover by means of installer.

- 7 Measure necked-down shaft of necked-down bolts.
- 8 Mount driven plates in correct sequence on flywheel.
- 9 Tighten necked-down bolts to 30–40 Nm and 90–100° angle of rotation.

- 1 Washer
- 2 Driven plate 1.5 mm
- 3 Driven plate 1.0 mm

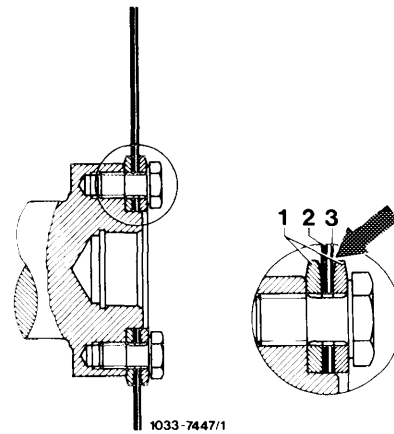

Attention!

One of the eight fastening bores is off center on pitch circle dia. (arrow). For this reason, the flywheel or driven plates can be mounted in a given position only. The hole patterns should be accurately aligned.

