

## 01–415 Removal and installation of cylinder head







Valve clearance	with engine cold (approx. 20 °C)	with engine warm (60 °C ± 15 °C)
Intake	0.10 <sup>1)</sup>	0.15 <sup>1)</sup>
Exhaust	0.20	0.25

<sup>1)</sup> 0.05 mm higher during lasting outside temperatures below –20 °C.

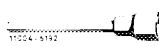
### Tightening torques

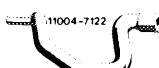
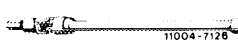
		Nm	
Cylinder head bolts	with engine cold	step 1	30
		step 2	60
		check at approx. 80 °C	60
Bolts for cylinder head cover		5	
Fastening bolts for camshaft sprockets		100	
Injection valves on cylinder head		10	

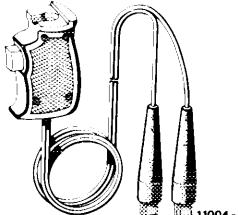
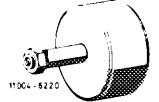
### Special tools

Screw driver socket 8 mm, 130 mm long		000 589 33 07 00
Screw driver socket 8 mm, 105 mm long, offset		000 589 34 07 00
Screw driver socket 8 mm, 1/2" square		116 589 00 13 00
Screw driver socket 8 mm, with hinged joint and extension		117 589 01 07 00
Screw driver 6 mm, 440 mm long		116 589 03 07 00
Valve adjusting wrench 17 mm		116 589 02 01 00
Contact handle for rotating engine		001 589 46 21 08
Impact puller for bearing bolt (basic unit)		116 589 20 33 00
Threaded bolt 6 x 50 mm		116 589 01 34 00

## Note

The cylinder heads cannot be used for light alloy engines, since the 5 center cylinder head screw holes are not uniform.

Remove cylinder head only from cooled-down engine.

Face cylinder head parting surface only in the event of porous or damaged spots. A slightly warped parting surface will adapt itself again when cylinder head is tightened.

Each cylinder head is located in relation to cylinder crankcase by means of 2 fitted sleeves and is fastened to cylinder crankcase by means of 18 cylinder head screws, 6 each per cylinder bore.

**Note:** Cylinder heads with longitudinal oil duct and feed bores for hydraulic valve clearance compensating elements can be provided with valve adjusting screws for manual valve adjustment when used as spare parts.

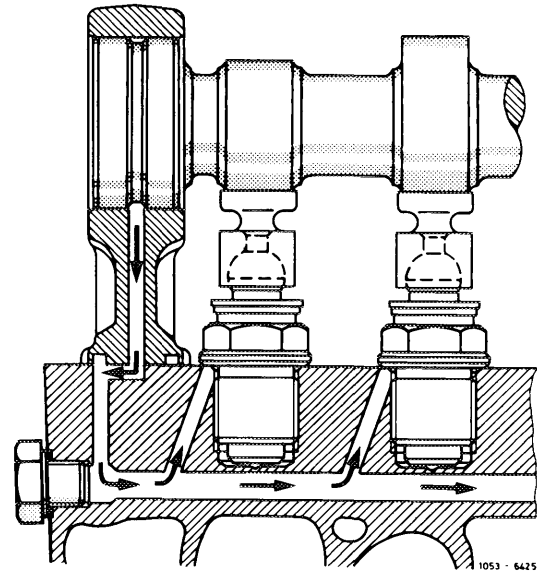

In a cylinder head with air duct and 4 bores, the 4 bores must be closed with tapered plugs (6 mm dia.) 116 997 00 05 when the cylinder head is used for an engine without air injection.

Starting model year 1980, the 4 bores in air duct have been enlarged from 6 to 7 mm dia. They must be closed with tapered plugs (7 mm dia.) 116 997 01 05 if the cylinder head is used for an engine without air injection.

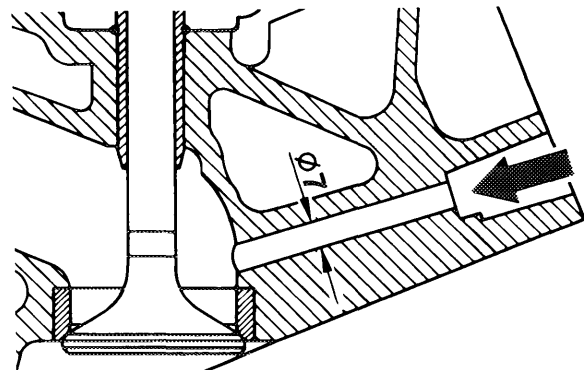

Provide tapered plugs made of aluminum for closing bores in air duct with Loctite AVX 86, part no. 002 989 87 71 and knock in.

Bore 6 mm: Dimension A = 5.9 mm dia., B = 6.33 mm dia.  
Bore 7 mm: Dimension A = 6.9 mm dia., B = 7.33 mm dia.

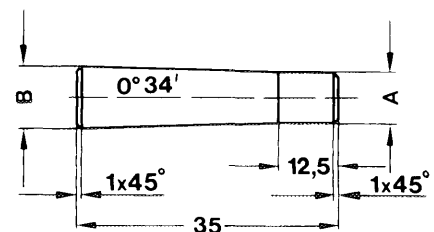

## Removal

---

RZ = righthand cylinder head

LZ = lefthand cylinder head

- 1 Drain coolant.

The drain plugs on crankcase are at the left and right.

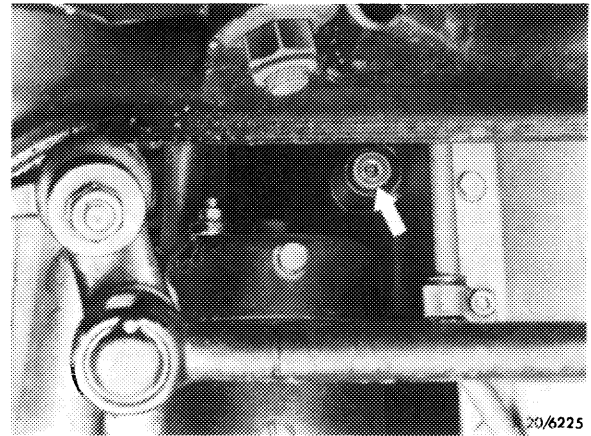

- 2 Righthand cylinder head: Remove battery.

- 3 Remove fuel line and injection valves.

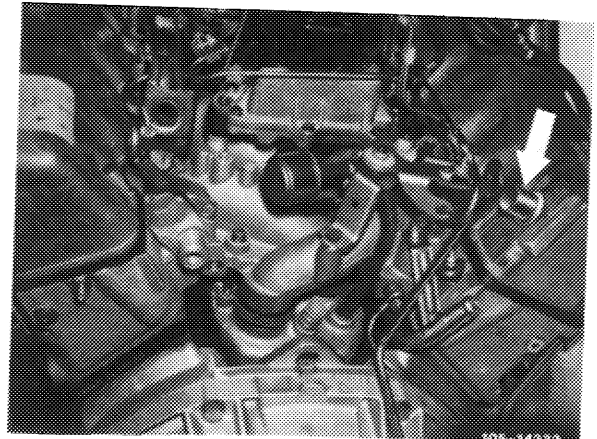

- 4 Push longitudinal regulating shaft in direction of front wall and remove or unscrew bearing bracket.

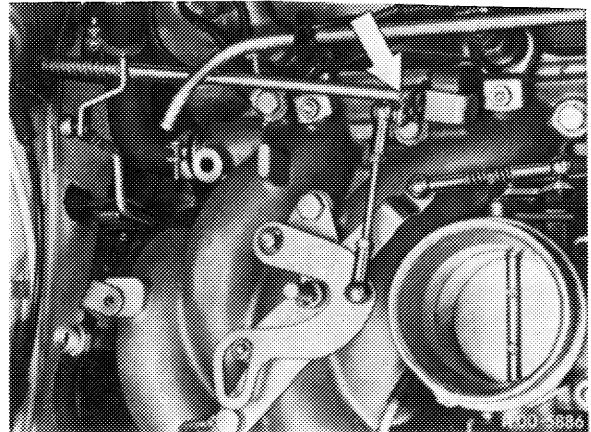

- 5 Remove intake pipe.

On engines with CIS injection system, remove intake pipe with mixture controller and air guide housing.

The intake pipe is guided by four set sleeves (14).

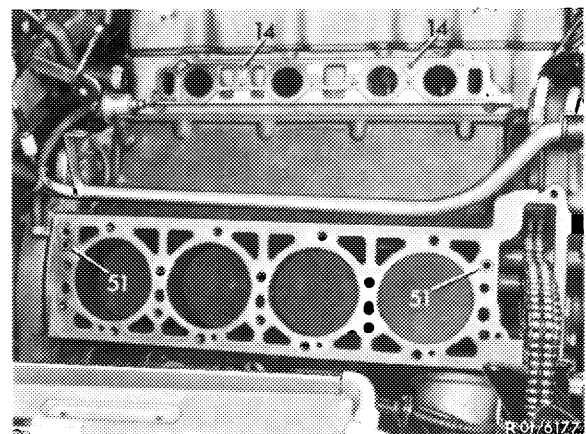

6 Righthand cylinder head: Remove alternator with mounting bracket.

7 Righthand cylinder head: Loosen oil dipstick guide tube for automatic transmission on cylinder head.

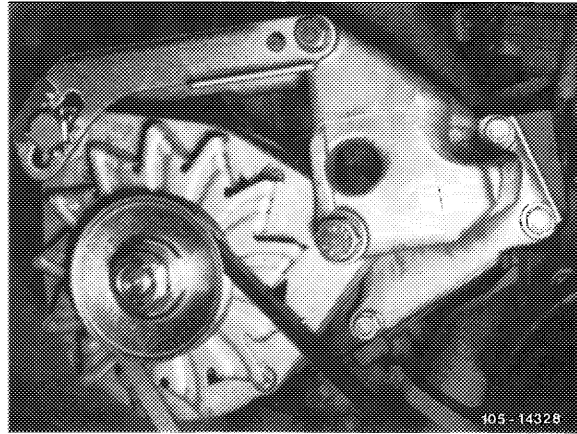

8 Lefthand cylinder head: Remove power steering pump with mounting bracket. For this purpose, remove ignition distributor.

9 Unscrew exhaust pipe on respective exhaust manifold.

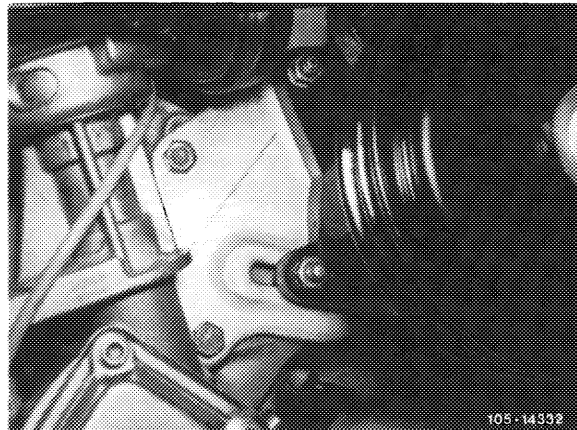

10 On USA vehicles, disconnect exhaust gas return line (arrows).

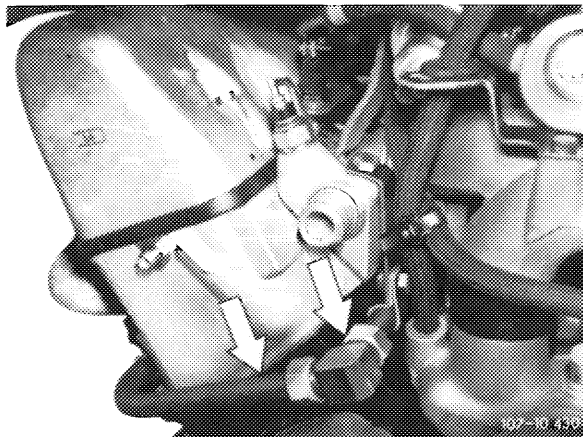

11 Remove chain tensioner (05-312).

12 Righthand cylinder head: Remove slide rail.

13 Lefthand cylinder head: Remove slide rail.

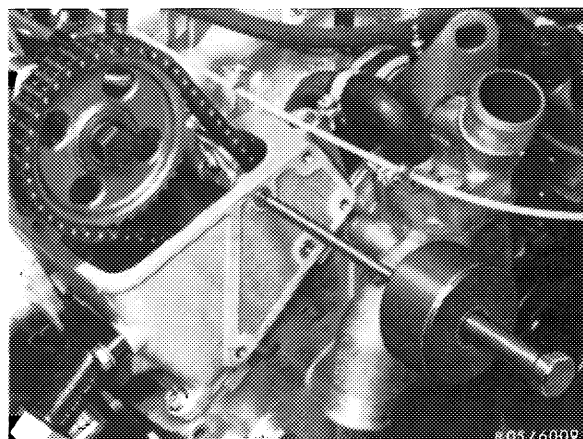

14 Mark camshaft sprocket and timing chain in relation to each other (arrows).

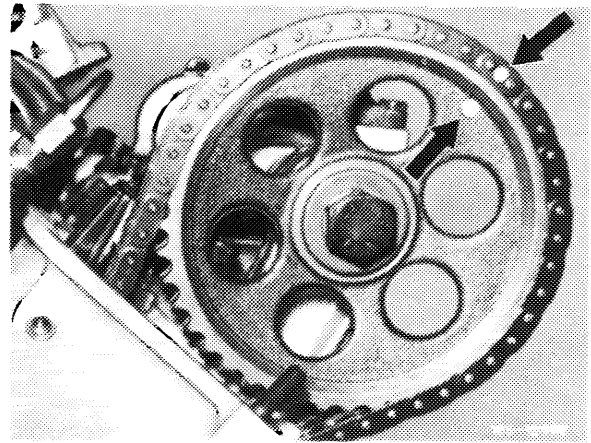

15 Unscrew cylinder head bolts vice versa to tightening diagram.

Loosen the M 8 bolts (a) with hex. socket wrench 116 589 03 07 00.

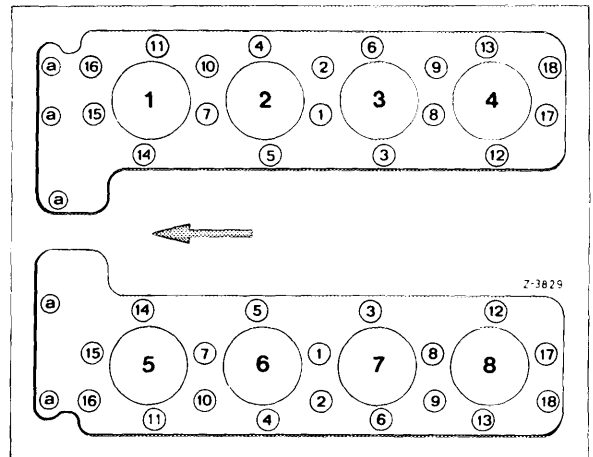

a Bolts M 8

**Notes:** Loosening and tightening of cylinder head bolts require various types of screw driver sockets.

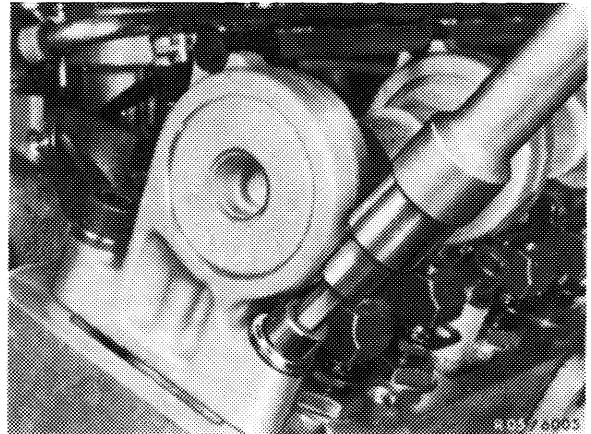

Screw driver socket 000 589 33 07 00

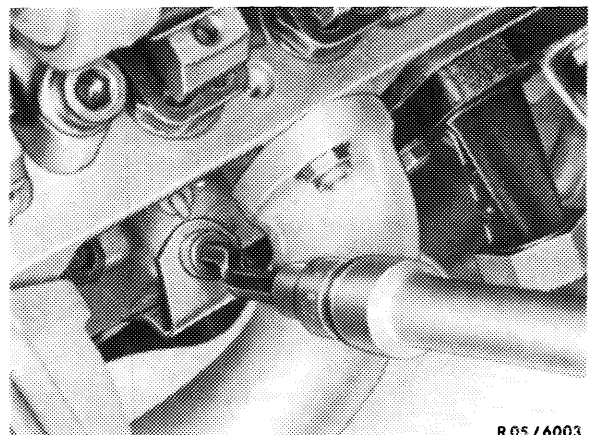

Screw driver socket 000 589 34 07 00

R 05 / 6003

Screw driver socket 116 589 00 13 00

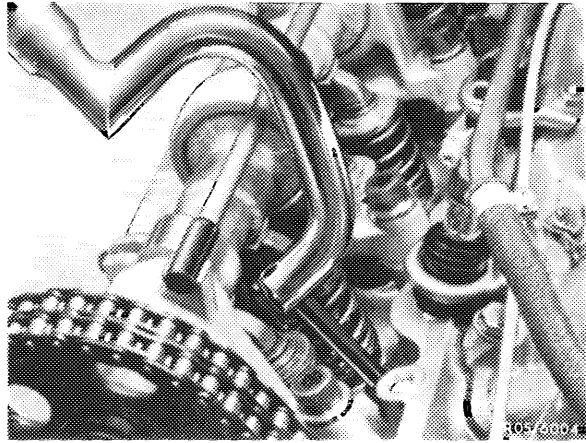

Screw driver socket 117 589 01 07 00

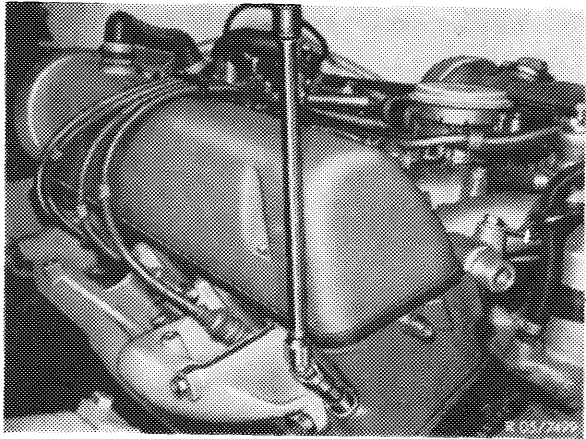

16 For removing righthand cylinder head, push tensioning rail with timing chain toward center of engine so that tensioning rail is not getting stuck.

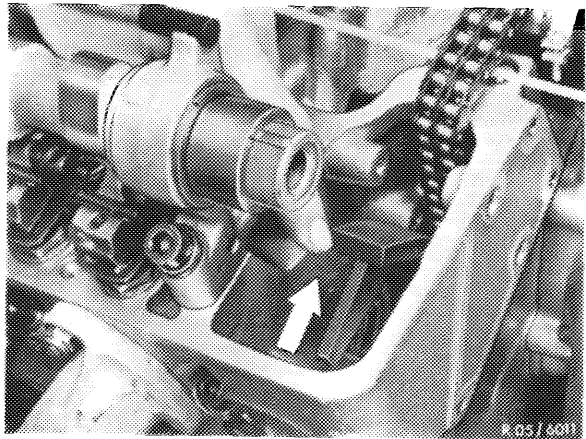

### Installation

17 Clean cylinder head and cylinder crankcase parting surface.

18 Mount new cylinder head gasket.

Cylinder head gaskets of engines 116.96 and 117.96 to 116.98 and 117.98 differ by the hole pattern of the 5 central cylinder head bolt holes.

- 11 Righthand cylinder head gasket
- 34 Lefthand cylinder head gasket

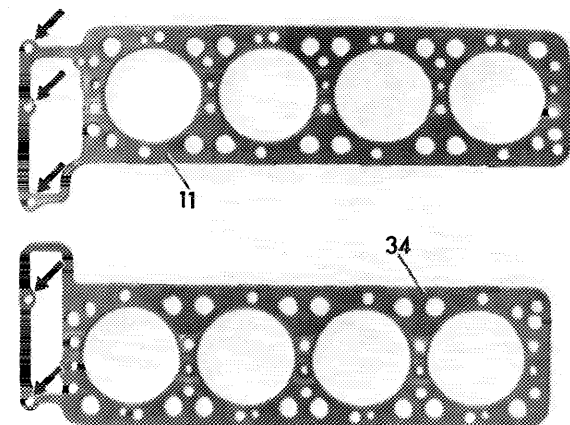

R 01/6175

**19 Mount cylinder head.**

Prior to screwing-in cylinder head bolts, provide threads and mounting surface as well as washers with oil.

**20 Tighten cylinder head bolts in steps in sequence of tightening diagram, starting with 1, first to 30 Nm and then to 60 Nm.**

**21 Tighten the M 8 bolts (a) to 25 Nm.**

**Attention!**

Cylinder head bolts M 10x165, M 10x90 and M 10x65 are 10 mm shorter than on light alloy engine.

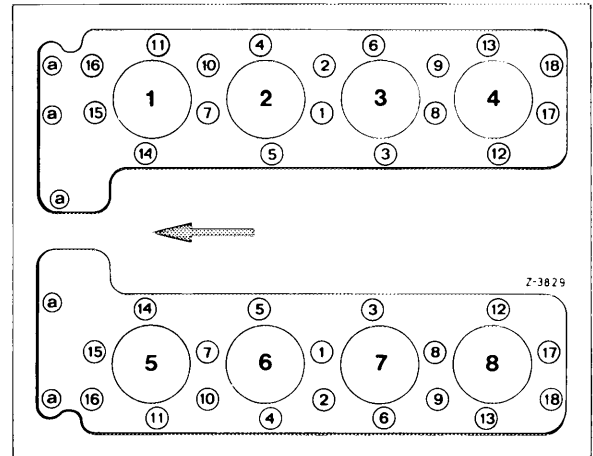

**22 Mount camshaft sprocket.**

The wide collar (arrow) on camshaft sprocket should face camshaft.

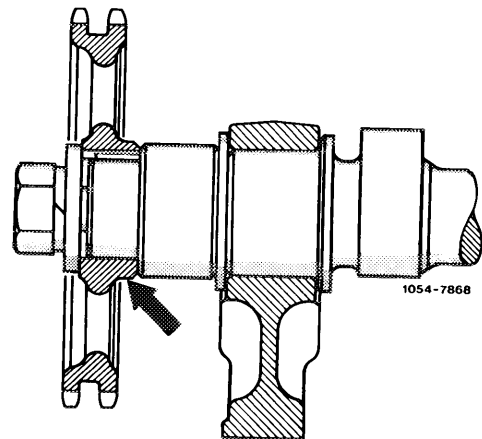

**23 Markings on camshaft should be in alignment at ignition TDC position of 1st cylinder.**

If the markings are not in alignment, check timing and adjust, if required.

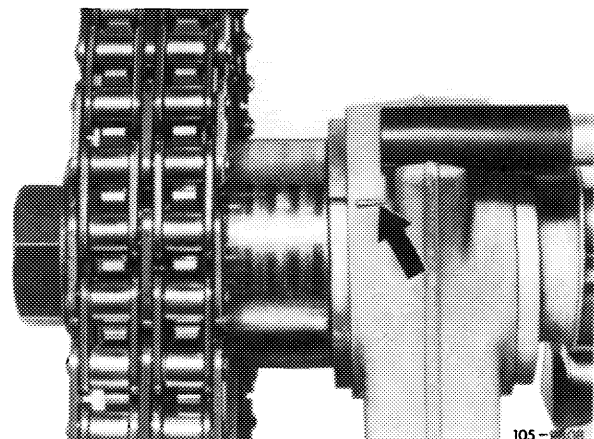

24 Check valve clearance and adjust, if required (05–210).

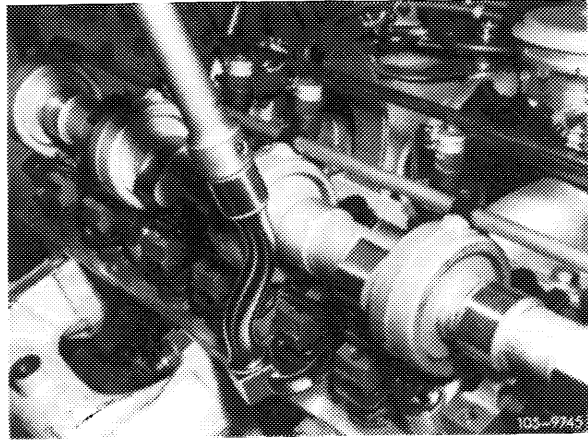

25 Check basic position of hydraulic valve clearance compensating elements with test gauge and adjust, if required (05–213).

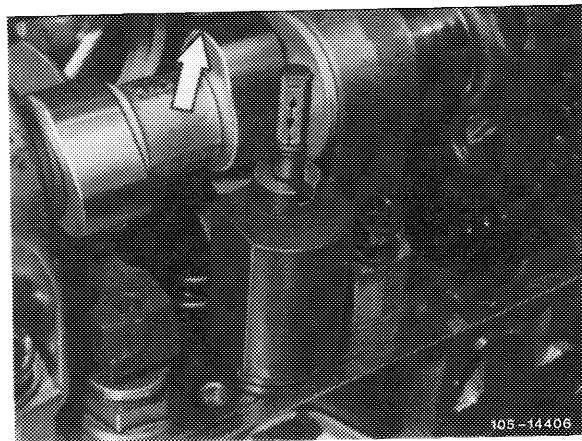

26 For further installation proceed vice versa.

27 Warm up engine.

28 Slightly loosen cylinder head bolts individually and retighten in sequence of tightening diagram, starting with 1, to 60 Nm.

**Note:** Retighten cylinder head bolts after 500–1000 km is not required with self-adjusting cylinder head gasket installed.

