

Note

A test is required if cold air is blown into legroom below 40 °C (104 °F) coolant temperature.

This function test can be performed only with completely cooled down engine and at an ambient temperature below 20 °C (68 °F).

With cold engine, coolant temperature below 20 °C (68 °F) the blower should not start at "AUTO-HI" or "AUTO-LO". As soon as the coolant has attained a temperature of approx. 40 °C (104 °F) the blower should start.

However, in position "DEF" the blower should also start immediately at a coolant temperature below 40 °C (104 °F).

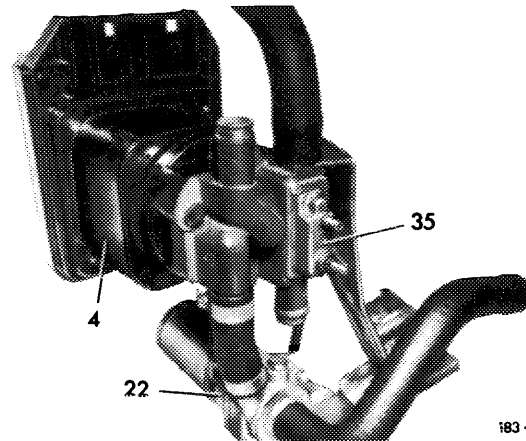

183-10872

Layout of temperature switch in regulating valve

- 4 Regulating valve
- 22 Heating water pump
- 35 Temperature switch

Testing

- 1 Switch-on ignition, but do not yet start engine.
- 2 Actuate pushbutton switch in the following sequence, paying attention to respective function of blower.

Pushbutton switch	Blower	Remedies
1. "DEF"	should start	Test vacuum system according to function diagram function diagram 2, (83-604)
2. "OFF"	off	
3. "AUTO-HI"	off	
4. "AUTO-HI" and start engine	should start only after attaining approx. 40 °C (104 °F) coolant temperature	