

83–538 Removal and installation of evaporator

Data

Face area/depth	6.3 dm ² /85 mm, 4 rows		
Version	copper pipes and aluminum ribs		
Tightening torques		Nm	(kpm)
Pressure hose to expansion valve	with Cu seal	30 ± 5	(3.0 ± 0.5)
	without Cu seal	45 ± 5	(4.5 ± 0.5)
Compensating line on evaporator	with Cu seal	17 ± 2	(1.7 ± 0.2)
Expansion valve on evaporator	with Cu seal	45 ± 5	(4.5 ± 0.5)
	without Cu seal	55 ± 5	(5.5 ± 0.5)
Suction hose on evaporator pipe	with Cu seal	60 ± 5	(6.0 ± 0.5)
	without Cu seal	70 ± 5	(7.0 ± 0.5)

Removal

- 1 Push back and cover both driver's seats.
- 2 Drain air conditioning system (83–516).
- 3 Unscrew hose line on expansion valve and on evaporator pipe and close (83–534, item 2 to 5).
- 4 Remove heater box with heat exchanger (83–100)

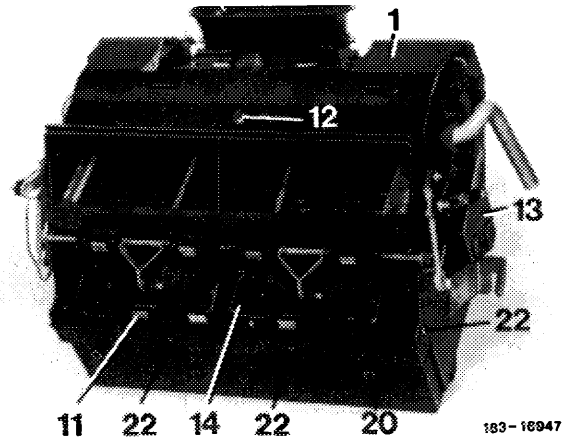

Note: In the event of leaks on evaporator or air conditioner unit (up to end of 78) completely renew air conditioner unit, since removal of evaporator or flap section from air conditioner unit is not possible without damaging housing.

Starting January 79 the air conditioner unit is sealed with a round cord between flap section and housing (glued up to end of 78) and both parts are riveted by means of 4 cup-type rivets (22).

For faster removal of condensate, the evaporator housing is provided with two additional connections (starting September 77).

- 1 Condensate hose
(new version starting September 1977)
- 2 Air conditioning unit
- 3 Condensate hose
(1st version remains installed)

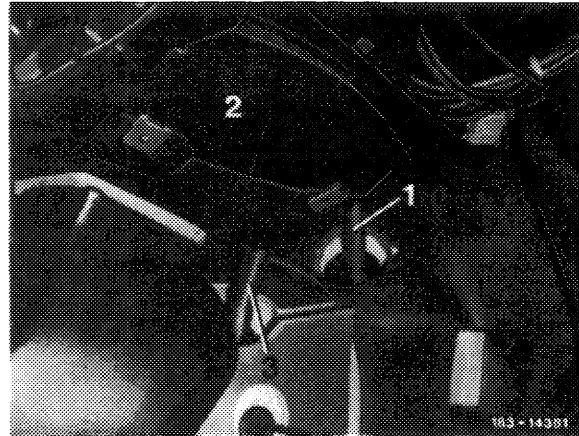

When renewing complete air conditioning unit (up to September 77) drill two additional holes to available condensate drains (3). For draining condensate, install two hoses (1) and rubber grommets. The condensate drains (3) remain in place for the time being. On vehicles with modified sealing (starting January 79) the evaporator can be renewed (as described below).

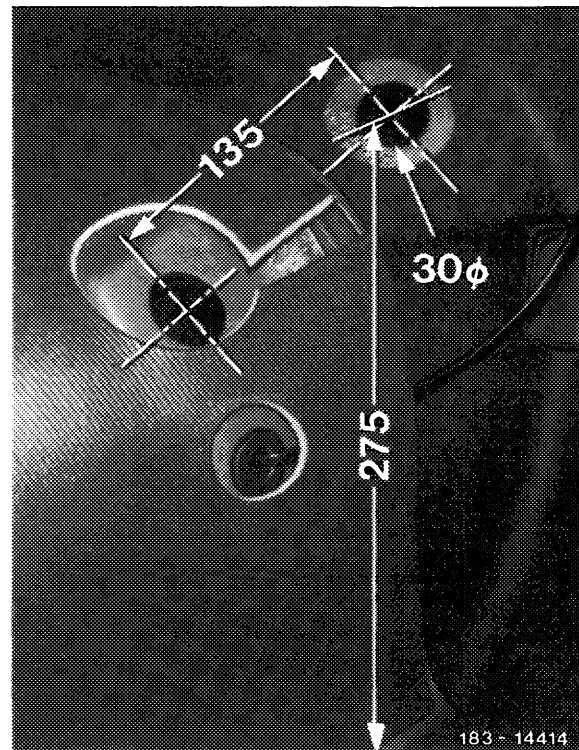

5 Remove tensioning springs (10) on front of heater box left and right.

6 Remove front end of heater box, while paying attention to bearings (18).

Air conditioning unit

- 1 Air conditioning unit
- 10 Tensioning spring
- 12 Guide tube for capillary
- 13 Slide piece
- 17 Front member
- 18 Bearing

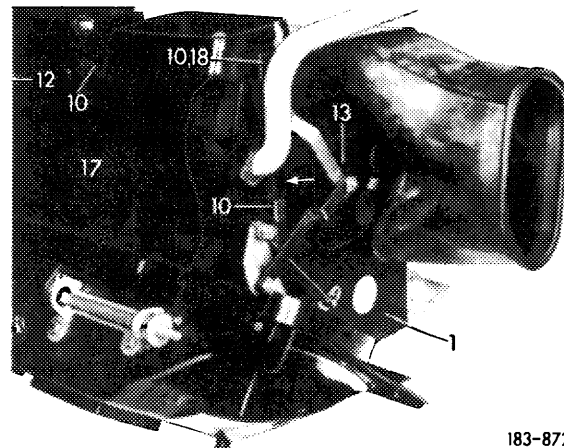

7 Remove heat exchanger (19).

Air conditioning unit

- 1 Air conditioning unit
- 11 Evaporator
- 12 Guide tube for capillary
- 19 Heat exchanger
- 20 Condensate drain

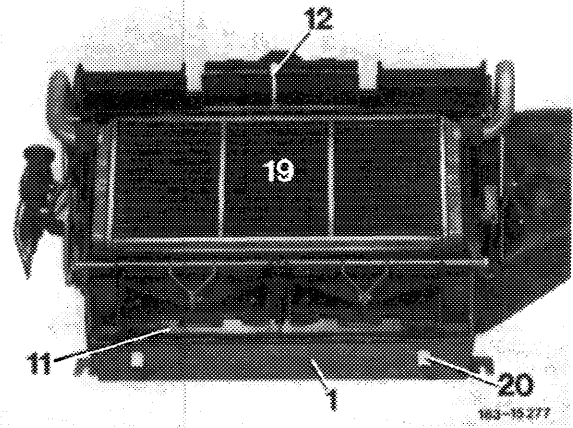

8 Pull guide tube (12) out of flap section (14) or evaporator.

9 Remove expansion valve (83-534).

10 Pull out both slide pieces (13) left and right on air conditioner unit in direction of arrow.

Air conditioner unit

- 1 Air conditioner unit
- 4 Expansion valve
- 11 Evaporator
- 12 Guide tube for capillary
- 13 Slide piece
- 14 Flap section
- 20 Condensate drain

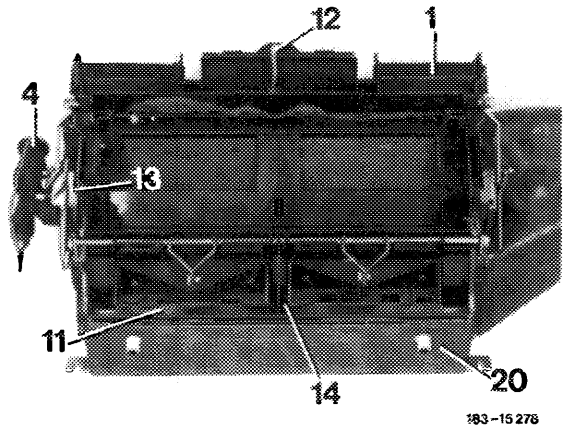

11 Drill out the four cup rivets (22) and remove flap section (14).

- 1 Air conditioning unit
- 11 Evaporator
- 12 Guide tube for capillary
- 13 Slide piece
- 14 Flap section
- 20 Condensate drain
- 22 Cup-type rivets

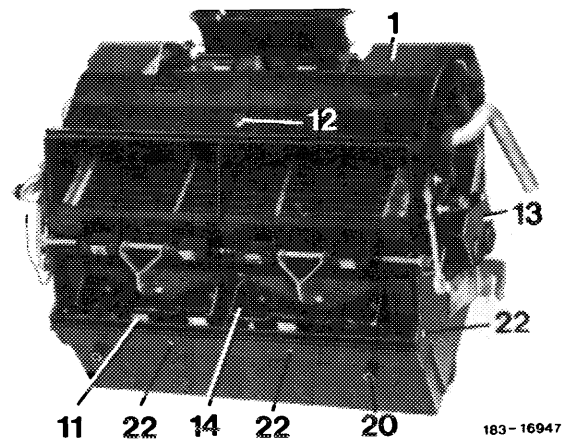

12 Unscrew both screws (15) and remove evaporator (11).

Air conditioner unit with expansion valve

- a Condensate drain
- 1 Air conditioner unit
- 4 Expansion valve
- 5 Capillary with temperature sensor
- 6 Pressure compensating line
- 7 Clip
- 8 Coupling nut
- 9 Closing plug
- 10 Sealing strip
- 13 Slide piece
- 15 Screw with washer and snap ring

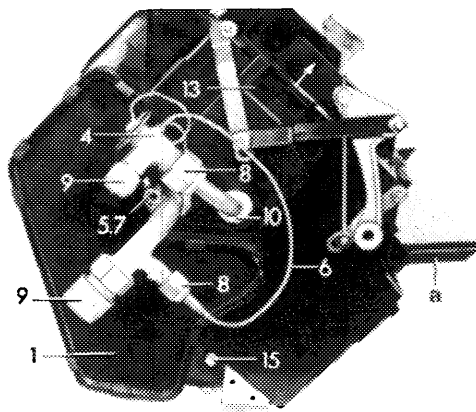

Layout of evaporator in air conditioner unit

- 1 Air conditioner unit
- 4 Expansion valve
- 11 Evaporator
- 16 Moltoprene seal

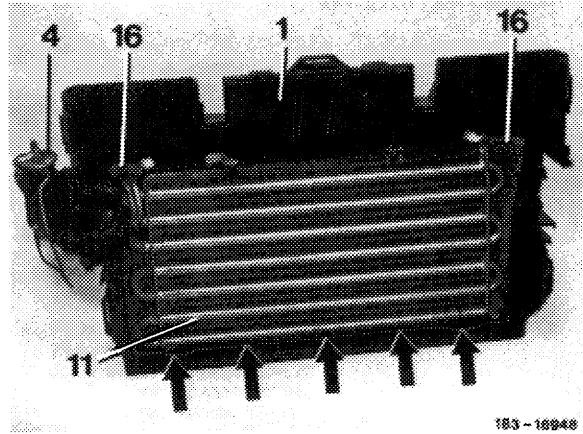

13 Mount expansion valve (4) on evaporator (83-534).

14 Screw on evaporator (11) with screws (15) in air conditioner unit.

Air conditioner unit

- 1 Air conditioner unit
- 4 Expansion valve
- 11 Evaporator
- 12 Guide tube for capillary
- 13 Slide piece
- 14 Flap section
- 20 Condensate drain

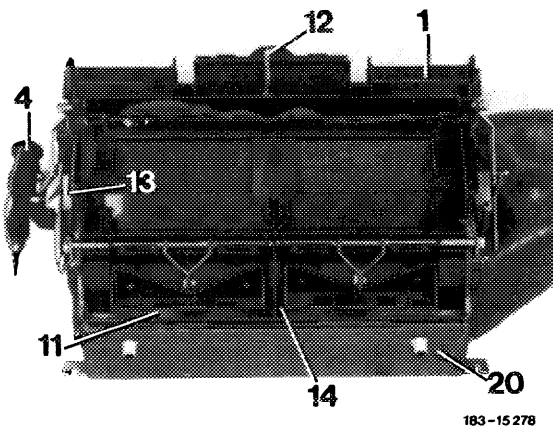

15 Place new round cord (arrow) into flap section (14).

16 Insert flap section (14) into housing and attach with slide pieces (13).

17 Check whether holes for cup-type rivets in flap section (14) and housing are in alignment. Then insert 4 new cup-type rivets (22).

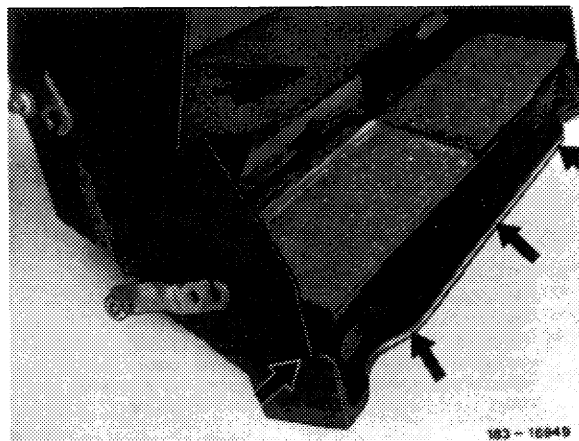
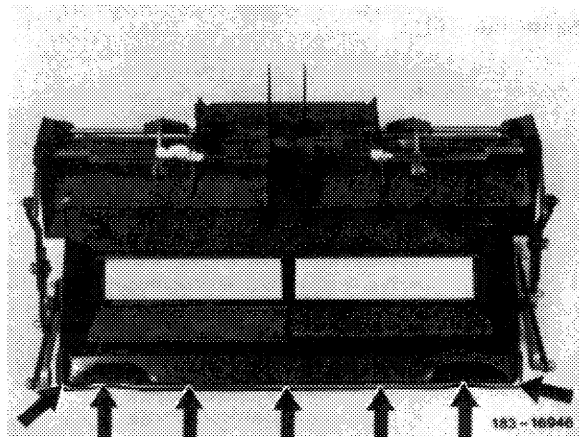

18 Close condensate drains (20) blind.

19 Fill water into air conditioning housing and check seal between flap section (14) and housing for leaks. Then remove blind plugs in condensate drains.

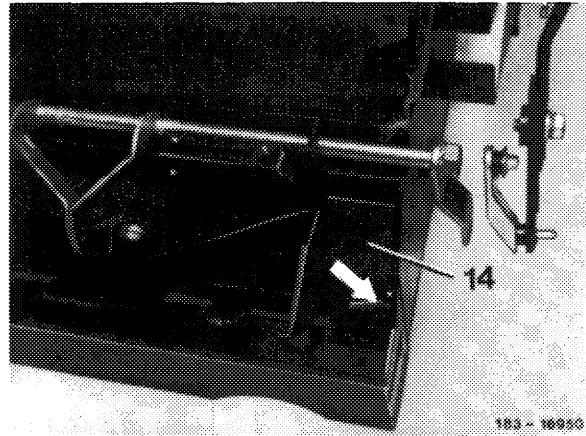

14 Flap section

20 Carefully introduce guide tube (12) through bore in flap section in evaporator. If required, bend capillary guide tube slightly. But be sure not to use force.

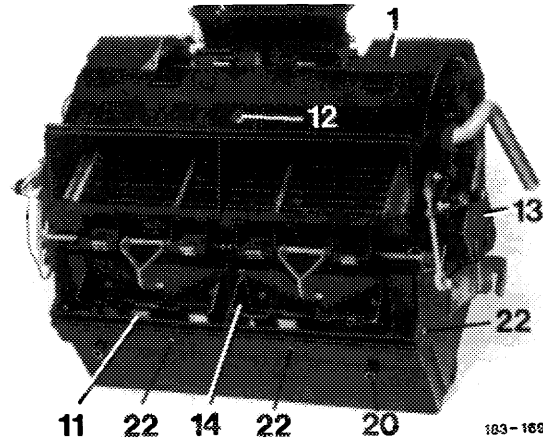

- 1 Air conditioning unit
- 11 Evaporator
- 12 Guide tube for capillary
- 13 Slide piece
- 14 Flap section
- 20 Condensate drain
- 22 Cup-type rivets

21 Install heat exchanger.

22 Mount heater box front section and attach with tensioning springs (10). Then seal bore for guide tube (12) with Teroson cord.

23 Install heater box (83-100). Mount condensate drain hoses to air conditioner unit and guide through grommets in tunnel.

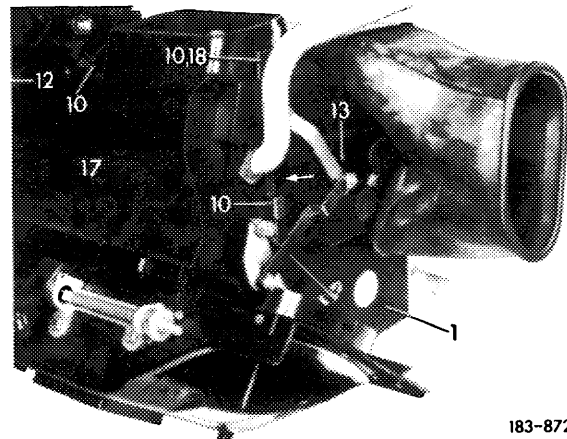

Air conditioner unit

- 1 Air conditioner unit
- 10 Tensioning spring
- 12 Guide tube for capillary
- 13 Slide piece
- 17 Front section
- 18 Bearing

24 Install capillary of temperature vacuum switch for air conditioner unit and slip completely into guide tube (5) to yellow mark.

25 Evacuate air conditioning system, fill up again, check for function and leaks (83-510, 512 and 514).

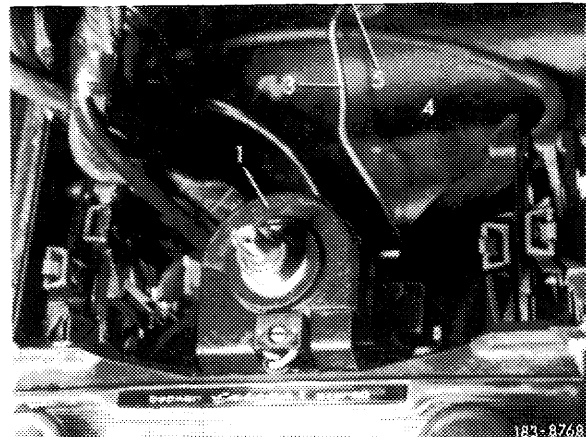

Layout of temperature sensor

- 1 Temperature vacuum switch
- 3 Capillary
- 4 Air conditioner unit
- 5 Guide tube for capillary