Special tools

Remover and installer for
valve insert



000 589 24 61 00

Conventional tools

Double open-end wrench 1/2 x 9/16"

Assembly tester with 3 filling hoses and vacuum pump
or evacuating and filling equipment (service unit)
for air conditioning system

e.g. made by
Christof Fischer
Augsburger Straße 289
7000 Stuttgart 60

Leak tester (Rilo-senior leak detector)

Leak test

If a checkup shows that the air conditioning system holds not enough refrigerant, the cause for the loss must be found. The leak test can be made with the system both filled or empty.

Leak test with system filled

With the system filled, leaks can be found with a leak tester (1).

For this purpose, switch on air conditioning system to full capacity and run engine at approx. 2000/min. Stop engine after approx. 2 minutes. With mouth (2) of leak tester, slowly check circuit or hold for some time close to spots where a leak is suspected, e.g. at connecting points, pipe connections, grease cup of compressor, on valves, on cooling air outlet etc. If refrigerant R 12 emerges at one of these spots, the leak is indicated optically or acoustically by the leak tester.

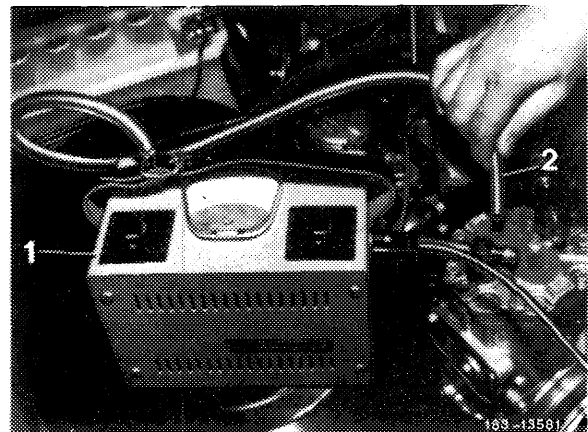

Leak test with system drained

When the system is completely drained, a vacuum pump (11) is used to evacuate the entire system, i.e. the max possible vacuum is generated. Checking vacuum with a vacuum gauge permits finding out whether the system has no large leaks. Check oil level in compressor first (83-520).

If there is a leak, the pressure gauge reading will increase, i.e. the vacuum is reduced. For accurate determination of the leaking point, fill system with approx. 100 g refrigerant R 12 and perform leak test with a leak tester.

Evacuation with assembly tester

- 1 Unscrew closing caps (1) of line connections on both service valves.

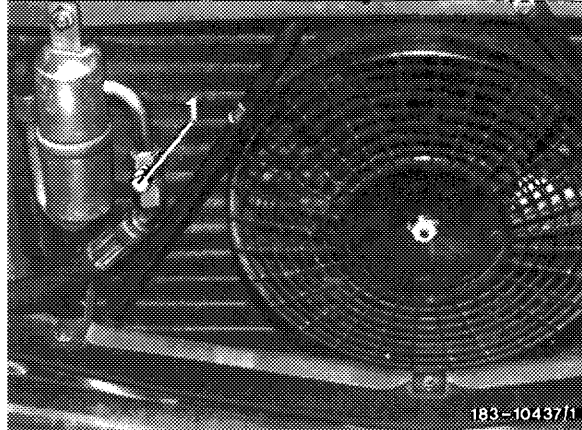

Frigidaire refrigerant compressor
Engine 100 (pressure side)

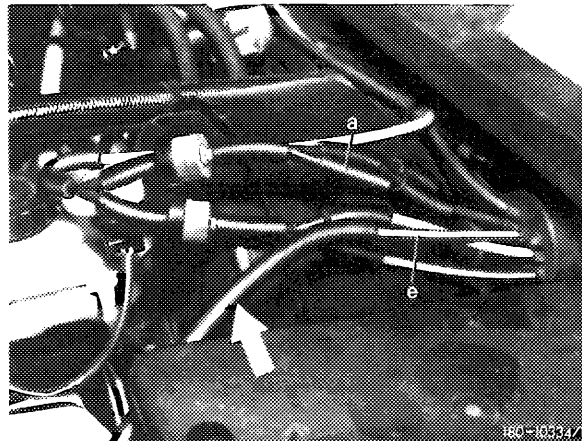

Frigidaire refrigerant compressor
Engine 100 (suction end)

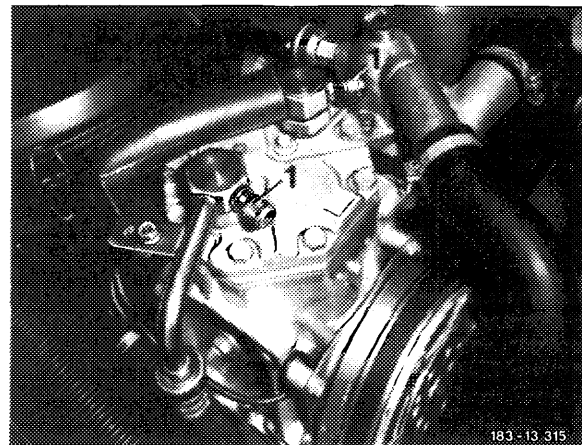

York refrigerant compressor
Engine 110

2 Connect hose lines (5, 8, 9 and 10). Make sure that the offset end of the hoses (5, 8 and 9) with the pressure pin for actuating the Schrader valve on connection (C) of assembly tester or on connection of both service valves is connected (hoses without pressure pin cannot be used here).

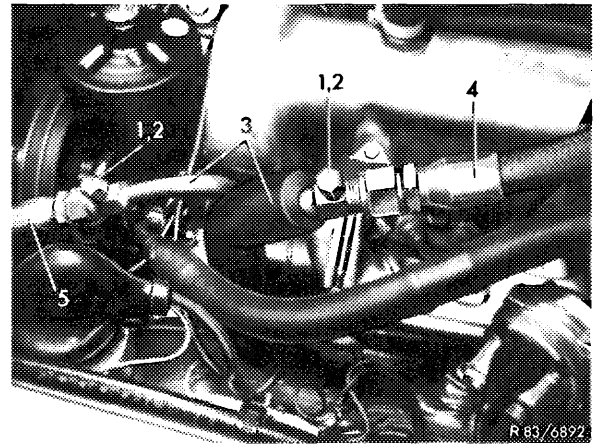

Frigidaire refrigerant compressor
Engines 116 an 117

3 Completely open valves (A and B) on assembly tester (2). Close valves on filling cylinder (12) or refrigerant bottle (16).

4 Operate vacuum pump (11) and evacuate system for at least 15 minutes.

5 Close valves (A and B) upon attaining the required vacuum (0.9 – 1.0 bar).

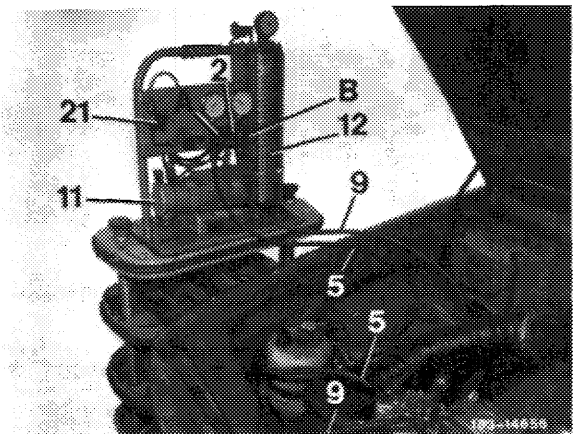

6 Disconnect connecting hose (8) or close valve (21) and stop vacuum pump (11). Open valves (A and B) after approx. 10 minutes.

7 If the vacuum pressure in relation to previously read value is down by more than 0.15 bar, the system has not been evacuated long enough or is leaking. Evacuate system once again. If the vacuum drops with regard to the previously read value, fill approx. 100 g refrigerant (gaseous) into system. Check entire system for leaks with leak tester and seal leaks. Then evacuate system again.

8 Close valves (A and B).

9 Fill system with refrigerant R 12 (83–514).

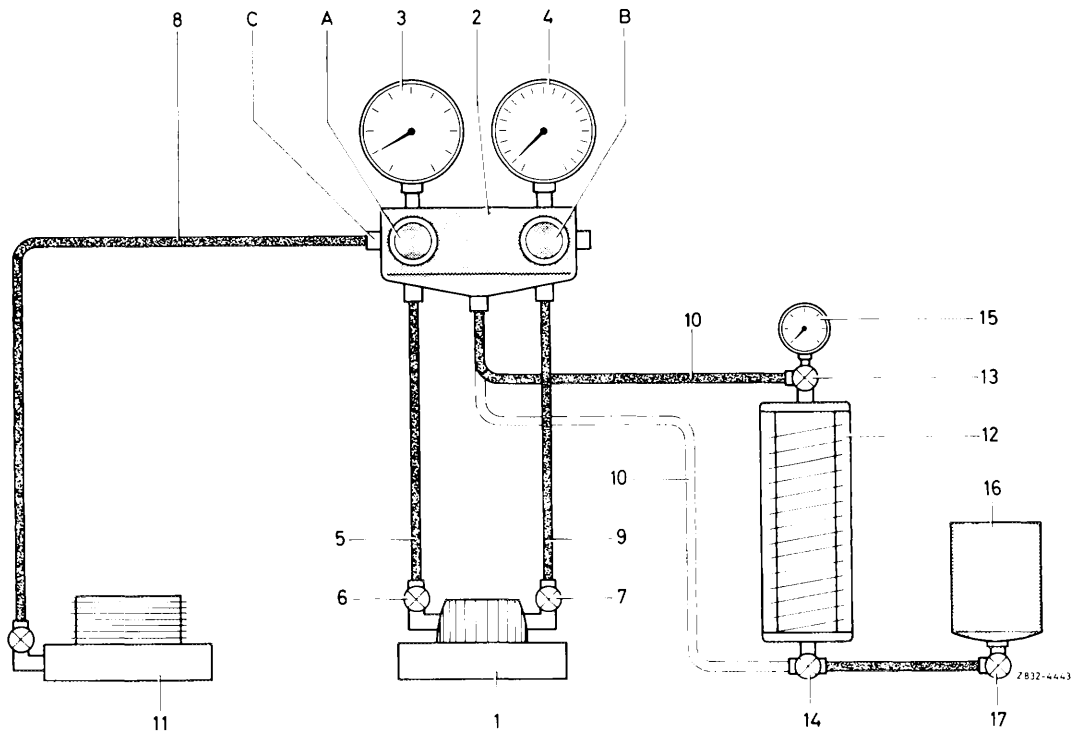

Assembly tester and filling cylinder with all connections

- | | | |
|-------------------------------------|--------------------------------|---------------------------------|
| A Valve on suction pressure gauge | 5 Hose line | 12 Filling cylinder |
| B Valve on high-pressure gauge | 6 Service valve (suction end) | 13 Upper valve |
| C Schrader valve on assembly tester | 7 Service valve (pressure end) | 14 Lower valve |
| 1 Refrigerant compressor | 8 Hose line | 15 Pressure gauge |
| 2 Assembly tester | 9 Hose line | 16 Refrigerant bottle with R 12 |
| 3 Suction pressure gauge | 10 Hose line | 17 Valve on refrigerant bottle |
| 4 High-pressure gauge | 11 Vacuum pump | |

Evacuation with service unit and vacuum meter (torr meter)

- 10 Connect service unit (item 1 and 2).
- 11 Connect valves (A and B) to assembly tester (2) and valves to filling cylinder (12).
- 12 Open valve (19 and 21) and operate vacuum pump (11).
- 13 Continue evacuating vacuum meter until pointer of vacuum meter stops. The max possible vacuum has now been attained.

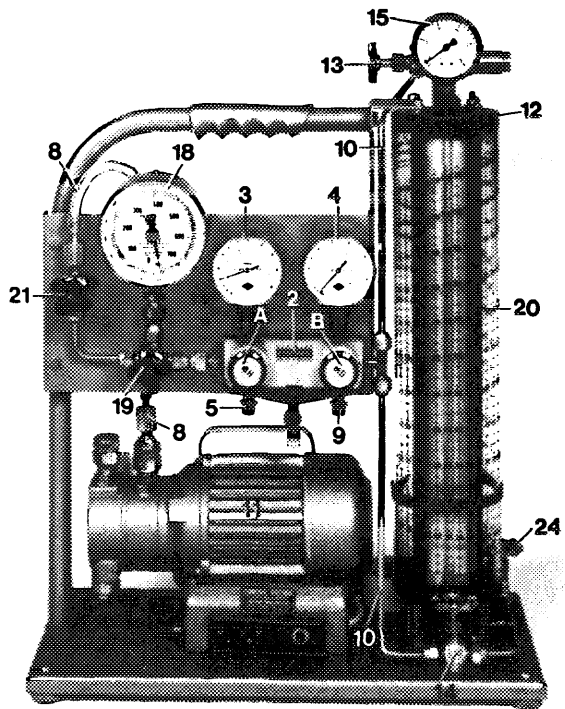

RB3-5696/1

14 Align drag pointer of vacuum meter with pointer.

15 Evacuate air conditioning system (according to item 3 to 5). The max possible vacuum is attained, when the pointer of the vacuum meter arrives at value of preset drag pointer.

16 Close valve (21) and switch off vacuum pump.

17 If the vacuum meter shows a steady pressure increase, the air conditioning system has a leak.

Evacuation with vacuum meter (torr meter)

Note: A vacuum meter (18) is located on the evacuating and filling device (service unit) between assembly tester (2) and vacuum pump (11).

The max attainable vacuum can be measured by means of the vacuum meter. A leak in air conditioning system is more clearly shown by a drop in vacuum.

The passage to vacuum meter is closed by valve (19).

The passage from assembly tester (2) to vacuum pump (11) or to valve (21) will remain open.

Upon evacuation, valve (19) should always remain closed. If the vacuum meter is loaded to more than 1.2 bar, it will become defective and can no longer be used.

- 18 Fill air conditioning system with approx. 100 g refrigerant, then check entire system for leaks with a leak tester and seal leak.
- 19 Evacuate air conditioning system once again.
- 20 Close valves (A and B as well as 19 and 21).
- 21 Fill system with refrigerant R 12 (83–514).