

80-900 Functional diagram central interlock

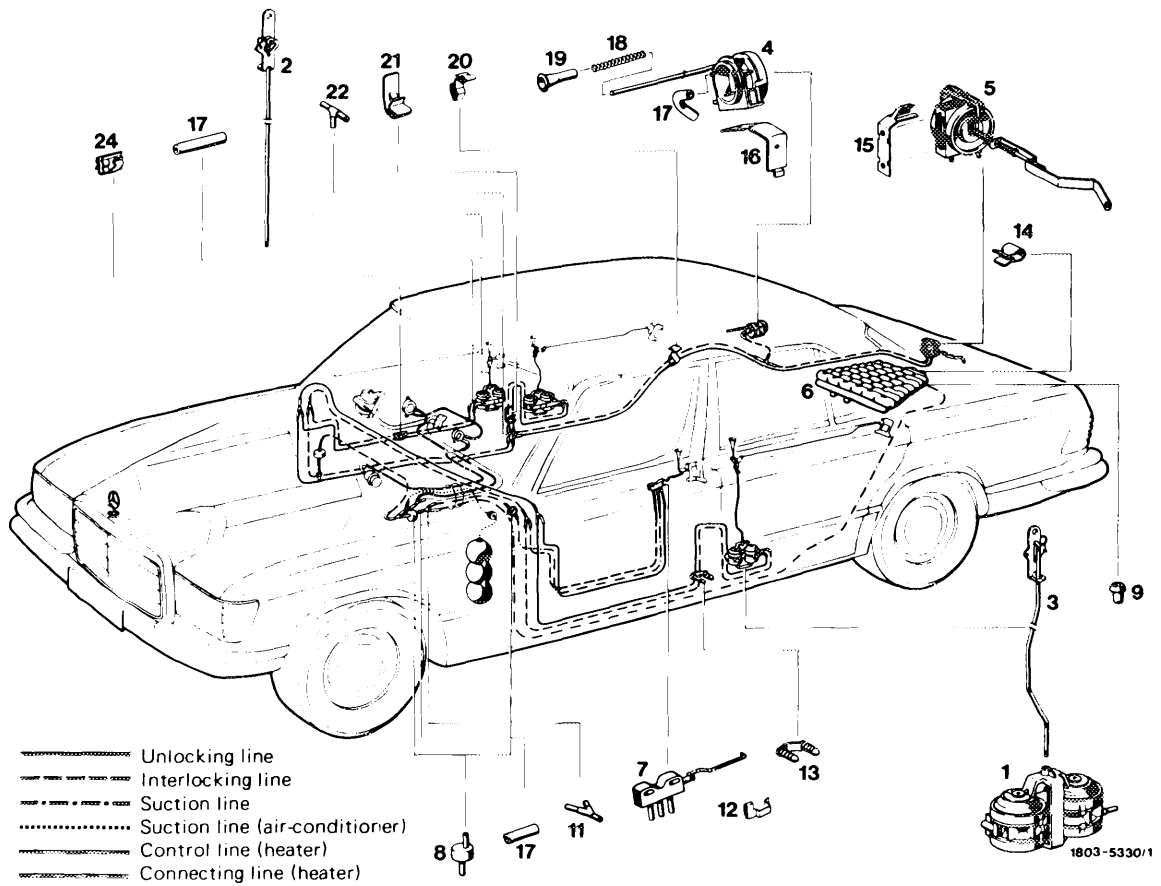

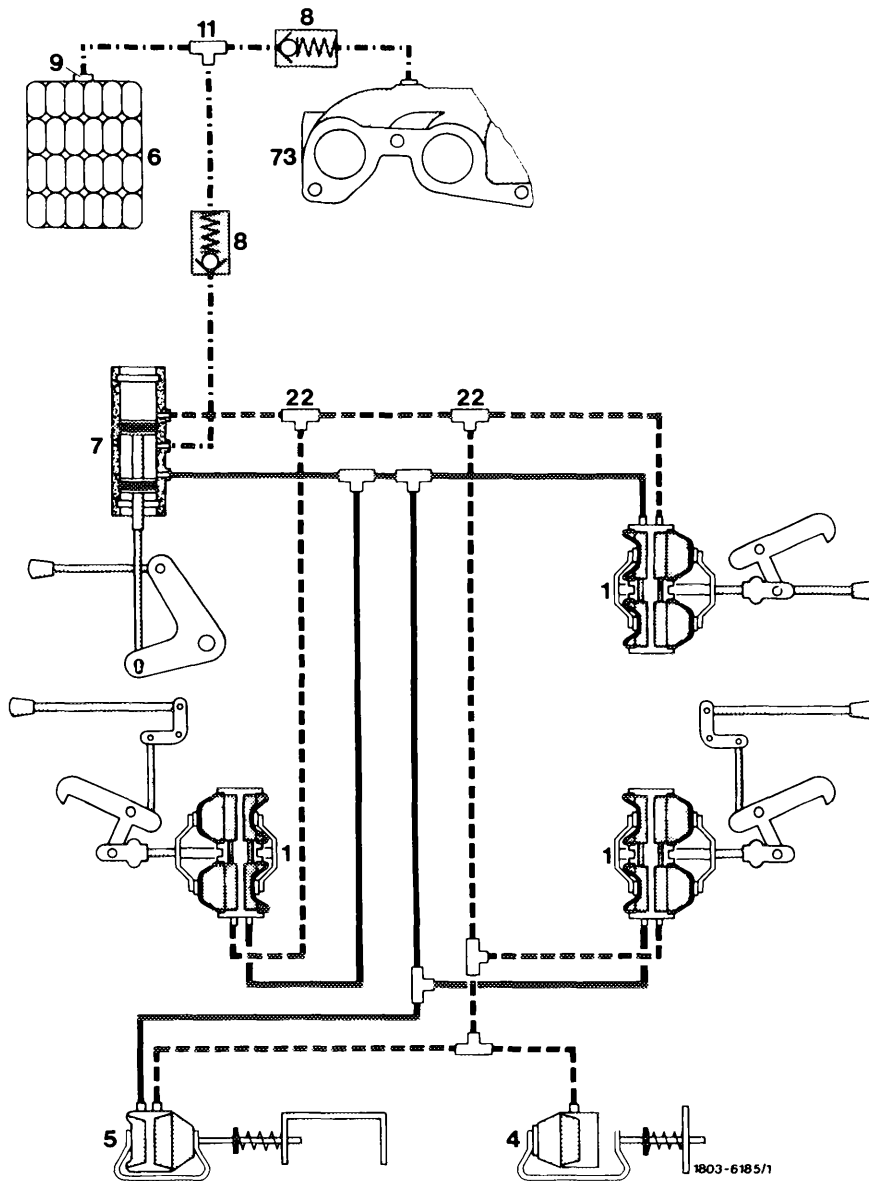

———— Unlocking line
 - - - - Interlocking line
 ····· Suction line

- | | |
|--|----------------|
| 1 Vacuum element (driver's and rear doors) | 8 Check valve |
| 4 Vacuum element (flap for tank filler neck) | 9 Seal |
| 5 Vacuum element (trunk lid) | 11 Distributor |
| 6 Vacuum supply tank | 22 Distributor |
| 7 Vacuum switch | 73 Intake pipe |

1803-6185/1