

46–520 Removal and installation of intermediate steering arm

Data

Model	Part No.	Version	Code No.
116.02	116 463 09 10	Lefthand steering	1609
116.032/033			
116.120	116 463 10 10	Righthand steering	1610
116.036	116 463 11 10	Lefthand steering	1611
	116 463 12 10	Righthand steering	1612



Adjusting value

Permissible difference in height of ball point position between pitman arm and intermediate steering arm	4 mm
--	------

Tightening torques

	Nm
Self-locking hex. nut for attaching intermediate steering arm	120
Castle nut to track rod and drag link	35

Special tools

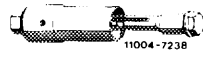
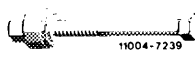
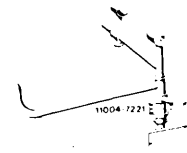
Puller for ball joint of track rod		186 589 10 33 00
Puller for ball joint of drag link		123 589 09 33 00
Remover for rubber slide bearing		116 589 01 33 00
Installer for rubber slide bearing		115 589 08 61 00
Measuring tool for control arm and ball point position		116 589 03 21 00

Removal

1 Unscrew castle nuts of drag link and track rod and unscrew castle nuts.

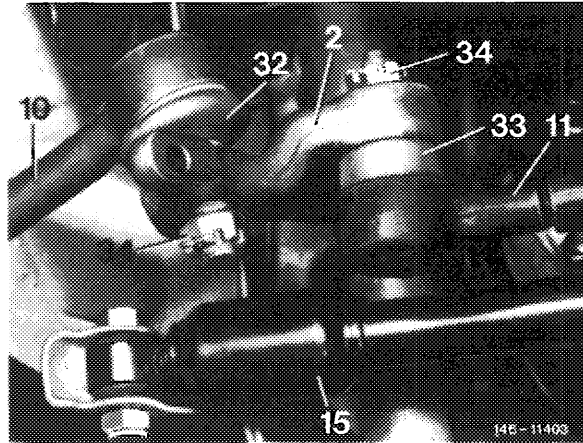

2 Force ball joint of track rod (10) from intermediate steering arm with puller (026).

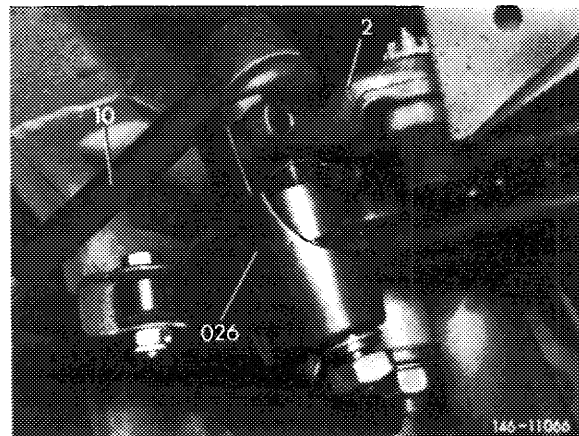

3 Force ball joint of drag link (11) from intermediate steering (2) with puller (020). On 1st version of drag link, pay attention to plastic cover and sealing ring.

Note: To prevent any damage to rubber sleeve of drag link 2nd version, force drag link off only with modified puller 123 589 09 33 00.

Puller 123 589 00 33 00 may be used only if the puller bell has been refinished as required.

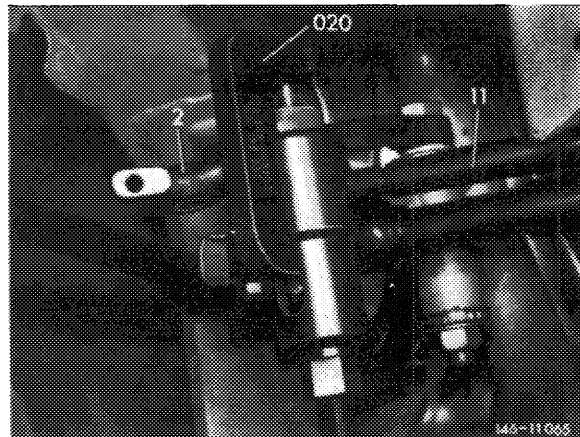

4 Unscrew self-locking hex. nut (9) from hex. screw (1). Remove sealing washer (4).

5 Remove hex. bolt (1) together with intermediate steering arm (2) and dust cap (8). Watch out for washer (3), if any, inserted between intermediate steering arm and dust cap.

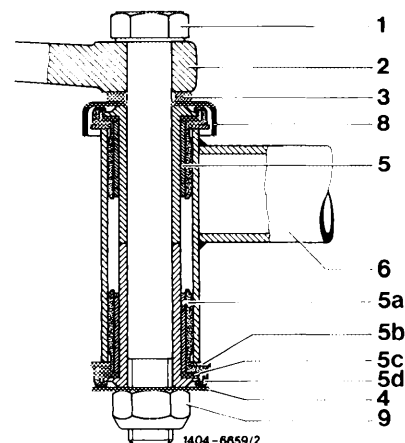

Checkup and repair

6 The intermediate steering arm cannot be checked with conventional workshop tools. **When in doubt**, particularly following an accident, replace **intermediate steering arm**.

Watch out for correct code number (arrow) of intermediate steering arm.

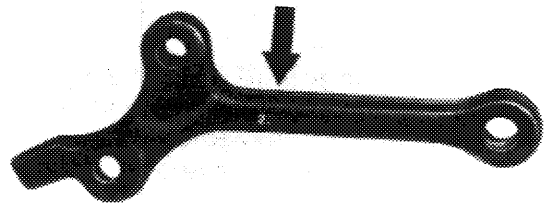

146-11420

7 Check rubber slide bearing in journal bearing (6) for wear and replace, if required.

For this purpose, lift sealing lip of rubber bushing (5d) with a screw driver.

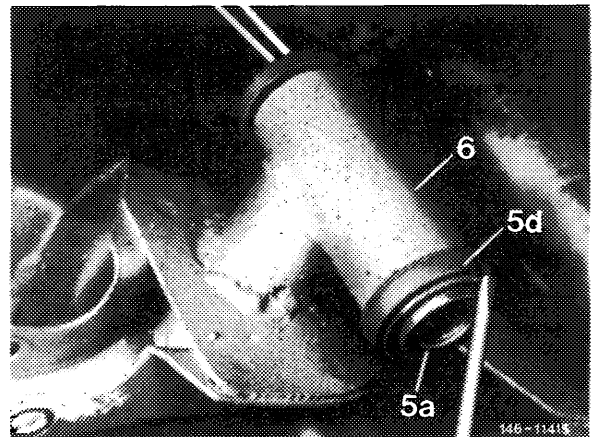

8 Remove slide bushing (5a) from rubber mount.

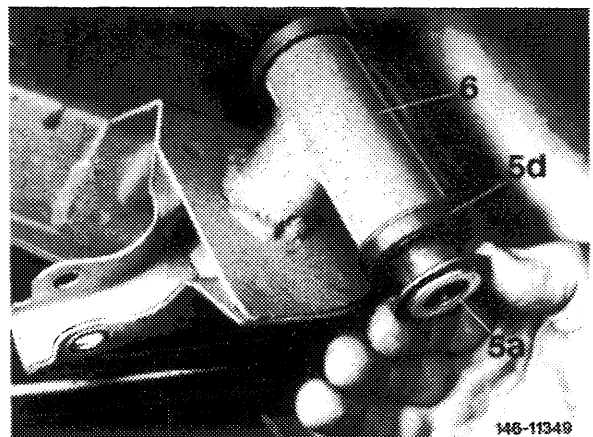

9 Remove both rubber bushings (5d) from journal bearing by means of remover (061).

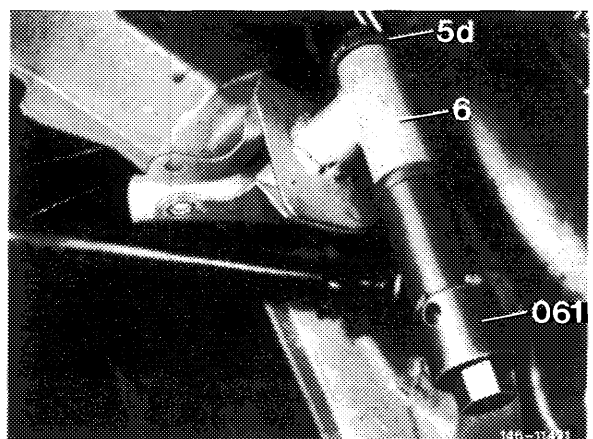

Installation

Note: In the event of complaints about noise the following rubber slide bearings may be installed:

a) Rubber slide bearings of 1st version. During installation, place steel washer part No. 115 463 01 52 (15) between both slide bushings. Note that the end play of both slide bushings in rubber bushings may amount to max. 0.5 mm. The end play is checked by pushing intermediate steering arm back and forth.

b) Rubber slide bearing 2nd version with longitudinal grooves.

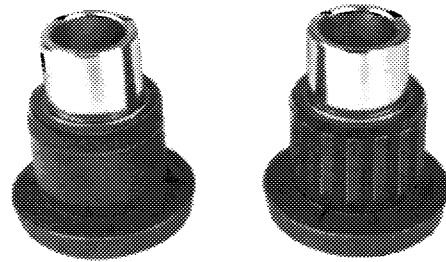
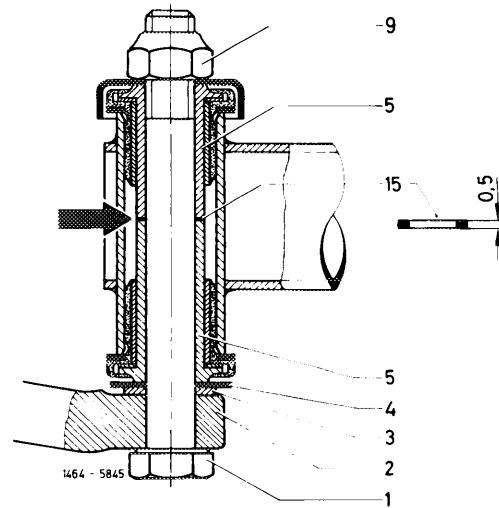

at left: smooth rubber slide bearing

at right: rubber slide bearing with longitudinal grooves

146-10143

10 Coat rubber slide bearing (5) outside with slide fluid, e. g. white oil and press into journal bearing (6) by means of installation tool (062).

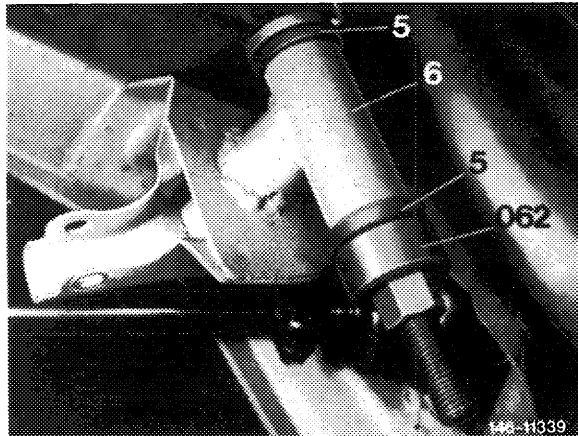

11 Place dust cap (8) on new upper rubber slide bearing.

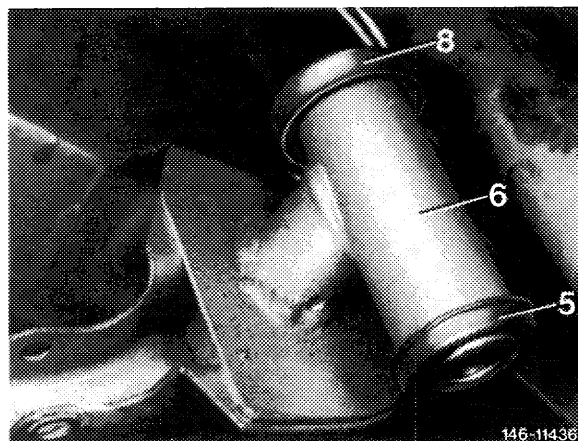

12 Insert hex. screw (1) with intermediate steering arm (2) and dust cap (8) into rubber slide bearings.

Note: Mount hex. screw with screw head facing intermediate steering arm, and use screws of grade 10.9 only.

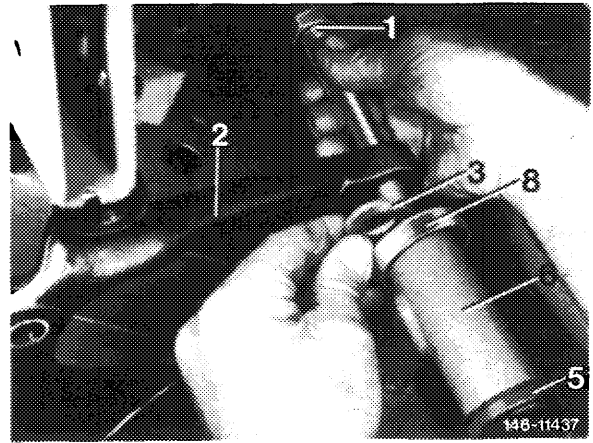

13 If a spacing washer (3) has been placed between dust cap (8) and intermediate steering arm (2), re-install washer.

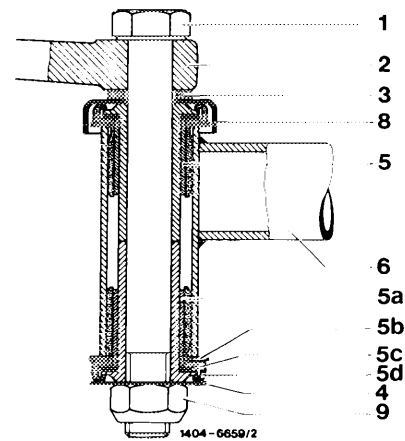

14 Mount sealing washer (4), screw-on standard hex. nut M 16 x 1.5 and tighten to approx. 70 Nm.

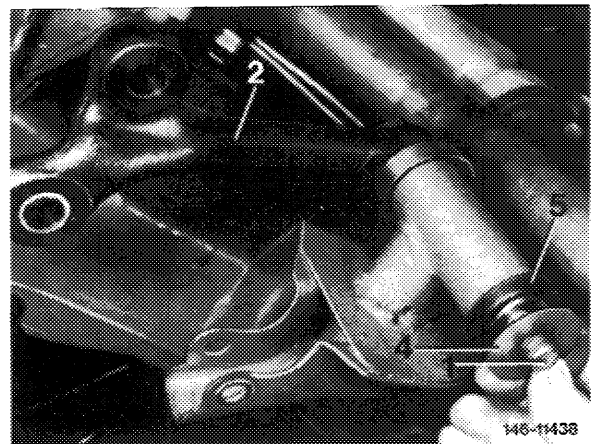

15 Measure permissible deviation in height of ball point position between pitman arm and intermediate steering arm by means of measuring instrument (01). Max. permissible difference 4 mm. If difference is higher, apply remedies described in job No. 40–320.

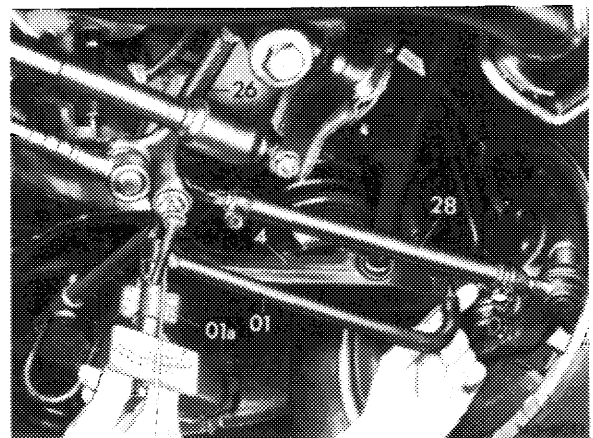

16 Unscrew hex. nut, then screw-on new self-locking hex. nut (9) and tighten to 120 Nm.

Note: After tightening self-locking hex. nut, at least one thread of hex. bolt should extend above hex. nut.

Attention!

Always replace self-locking hex. nut on principle.

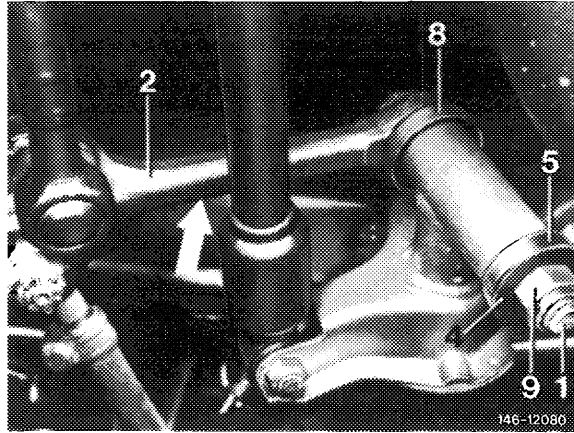

17 Check whether intermediate steering arm can be turned to the left and right without binding.

18 Check rubber sleeve (32) on joint of track rod. If sleeve is damaged, check joint for wear and replace, if required (46-540).

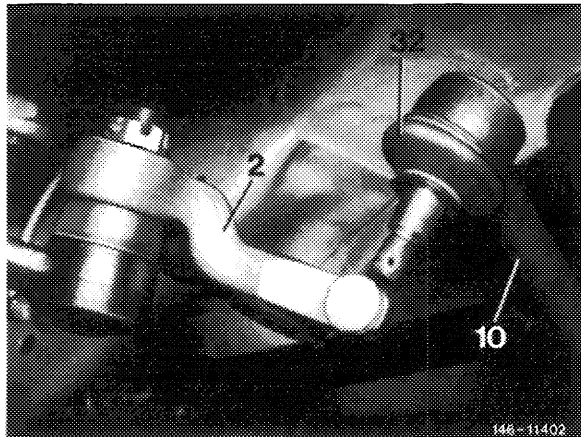

19 Check joint of drag link for wear and replace drag link, if required. On drag link 1st version, place sealing ring (35) and plastic cover (33) on ball joint (46-550).

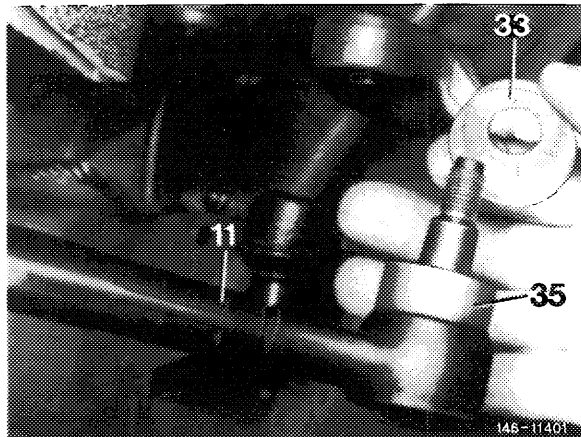

20 On drag link 2nd version, check rubber sleeve (32) on joint. If the sleeve is damaged, check joint for wear and replace, if required (46-550).

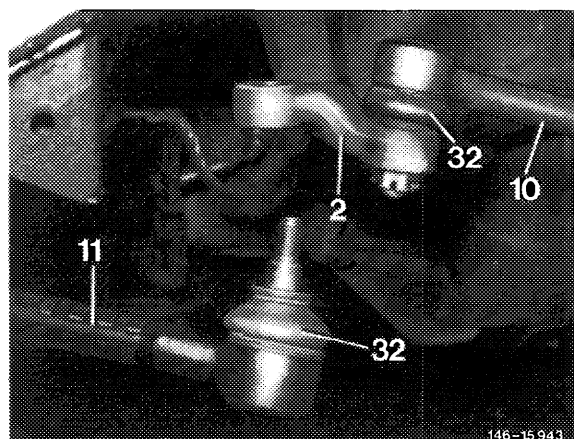

21 Attach track rod and drag link to pitman arm, cotter castle nut. Tightening torque 35 Nm – reference value.

22 Check wheel adjustment on front axle (40–320).

