

A. Rear axle center piece with lateral bearing caps

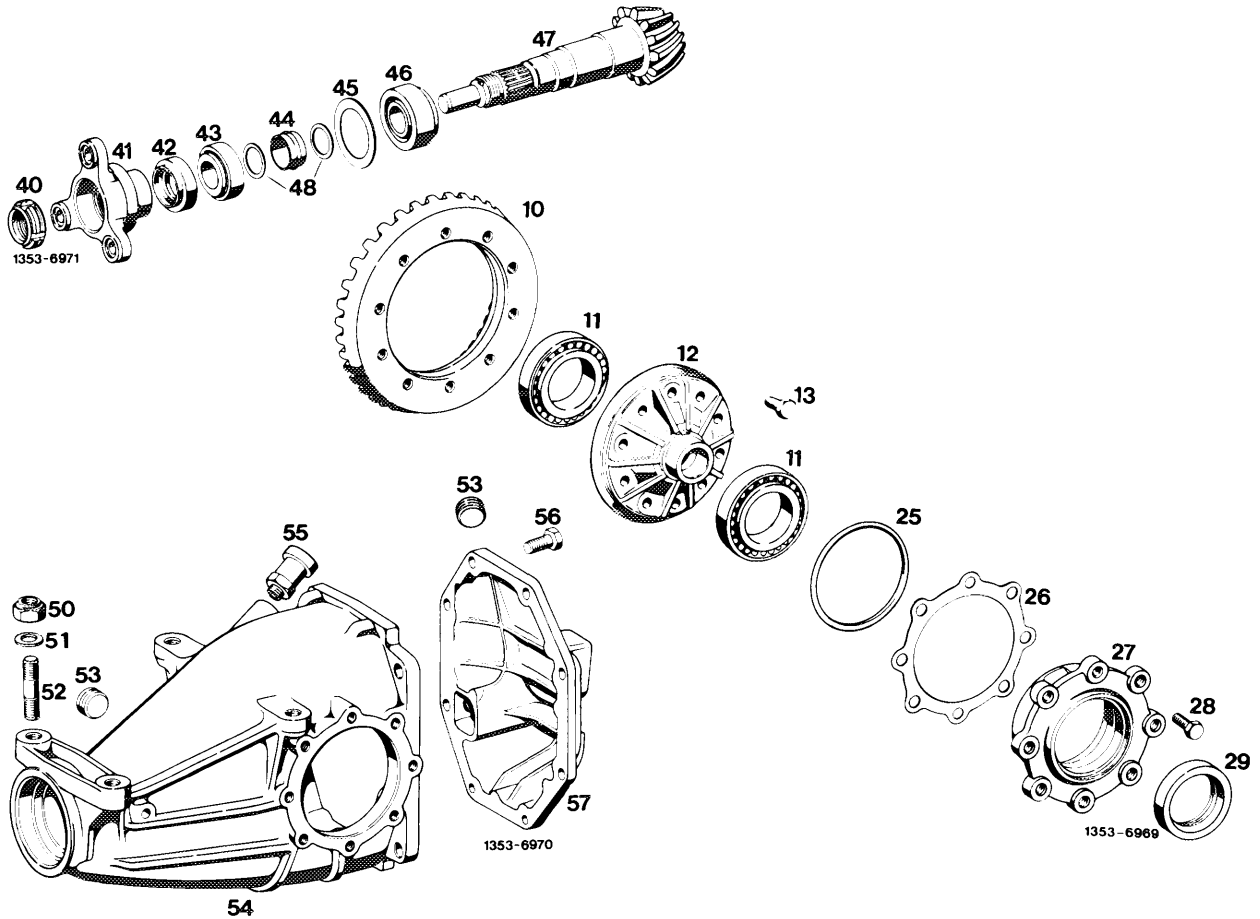

10	Ring gear	Check for damage and wear For assembly, heat to 60–70 °C
11	Tapered roller bearing (differential)	Check for damage and wear
12	Differential housing	Check for damage
13	Hex. head screw normal or self-locking	Renew, pay attention to tightening torque and length, refer to table
25	Sealing ring	Renew
26	Compensating washer	
27	Bearing cap	Check for damage
28	Hex. head screw	Tightening torque 20 Nm
29	Radial sealing ring	Renew
40	Slot nut or double hex. collar nut	Renew, secure by peening collar
41	Universal flange	Check, renew, if vertical runout exceeds 0.06 mm after resetting several times
42	Radial sealing ring	Renew
43	Small tapered roller bearing (drive pinion)	Check for damage and wear
44	Spacing sleeve	Renew

45	Compensating washer	
46	Large tapered roller bearing (drive pinion)	Check for damage and wear
47	Drive pinion	Pay attention to mating no., check for damage and wear. Refer to note: A item 28
48	Washer	Renew
50	Self-locking nut	Renew, tightening torque 100 Nm
51	Washer	
52	Stud	Check for damage, tightening torque 50 Nm
53	Closing plug	
54	Rear axle housing.	Check for damage
55	Breather	Renew
56	Hex. screw	Tightening torque 45 Nm
57	End cover	Check for damage, clean parting surface and coat with sealing compound

Oil types and capacities

Standard differential	Hypoid gear oil SAE 90 refer to specifications for service products page 235	
Differential with restricted slip (positive traction) (name plate on rear axle housing)	Special Hypoid gear oil refer to specifications for service products page 235.3	
Capacity	large center piece ¹⁾	1.3 litres
	small center piece ¹⁾	1.0 litre ²⁾

¹⁾ Refer to installation survey rear axle center piece 35–500

²⁾ On models 114 and 115 with rear rubber bearing of rear axle 1st version (cast iron end cover)
the oil capacity amounts to 1.15 liter.

Gear wheel (rotor) for rpm sensor on vehicles with ABS

Part number	Ratio	Number of teeth
123 353 01 85	4.08	23
123 353 02 85	3.92	24
123 353 03 85	3.69	26
123 353 04 85	3.58/3.54	27
123 353 05 85	3.46	28
126 353 00 85	3.27	29
126 353 01 85	3.06/3.07	31
126 353 03 85	2.82	34
126 353 04 85	2.72	35
126 353 06 85	2.47	39
126 353 05 85	2.24	43

Compensating washers for adjusting backlash and spread

Thickness	large center piece ¹⁾	0,9 to 1.4
	small center piece ¹⁾	0.6 to 1.9
Steps		0.05 to 0.05

Note: If required, grind one compensating washer to required thickness.

Adjusting values of gear assembly

Backlash of gear assembly		0.08–0.14 mm
Adjustment of tapered roller bearings for differential: Tapered roller bearings are provided with the required preload by widening (spreading) rear axle housing by	large center piece ¹⁾	0.15–0.20 mm
	small center piece ¹⁾	0.10–0.15 mm
Permissible tolerance of adjusting dimension "A" of drive pinion		+ 0.01 – 0.02
Adjustment of tapered roller bearing of drive pinion by measuring friction torque when rotating drive pinion with friction torque wrench ²⁾	new tapered roller bearing	120–140 Ncm
	used tapered roller bearing	50–100 Ncm

¹⁾ Refer to installation survey rear axle center piece 35–500.

²⁾ For correct adjustment of tapered roller bearings tighten slot nut or double hex. collar nut on universal flange until the specified friction torque is attained when rotating drive pinion. For checking friction torque when rotating drive pinion, the differential with ring gear should not be installed.

Compensating washers for adjusting drive pinion

Thickness	large center piece	1.5 to 2.4
	small center piece	1.5 to 1.8
Steps		0.05 to 0.05

Note: If required, grind one compensating washer to required thickness.

Fastening screws for ring gear

Center piece version	Flange thickness of differential housing	Length of hex. screws	Part number
Large	10	22	116 990 02 01
	8	20	126 990 01 01
	10	20	128 990 00 01
Small	8	18 standard	123 990 16 01 (replaced)
		18 self-locking	123 990 30 01

Universal flange on drive pinion

Dia. of running surface for radial sealing ring on universal flange	when new	40.00 39.84
	minimum dia. for repairs ¹⁾	
Running surface of universal flange		without thread
Permissible vertical runout of sealing surface of universal flange		0.06

¹⁾ Refinish running surface for seal in an emergency only.

Compensating washer between inner sychromesh joint and differential housing

Spacing ring	Thickness	from 2.6 to 3.4
	Steps	from 0.1 to 0.1

Tightening torques

Nm

Hex. screws for fastening rear
axle end cover to rear axle housing

45

Fastening screws
for ring gear

Small center piece

standard

80

self-locking

100

Large center piece

120

Studs in rear axle housing

50

Hex. screws for bearing caps
on rear axle housing

20

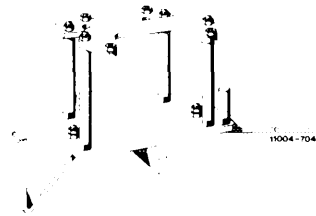
Special toolAssembly stand for
rear axle center piece

116 589 00 59 00

Holding wrench for universal flange

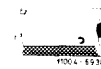

116 589 10 07 00

Slot nut socket 3/4" square for
slot nut on universal flange

115 589 01 07 00

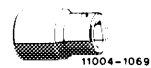
Socket 30 mm
double hex. 3/4" square for
double hex. collar nut on universal flange

126 589 02 09 00

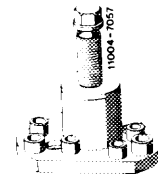
Puller for universal flange on
drive pinion

116 589 19 33 00

Installer and remover for pinion

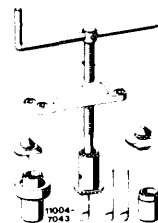





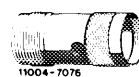

116 589 12 61 00

Puller for tapered roller bearing inner
races (basic tool)

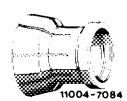
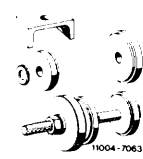
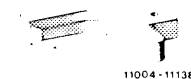
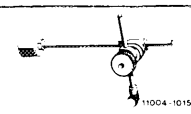
001 589 36 33 00

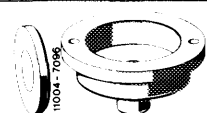
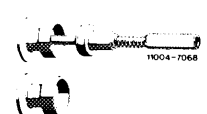
Extension for
puller 001 589 36 33 00

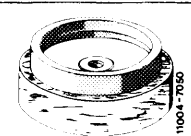
000 589 35 34 00

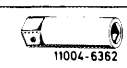
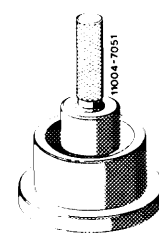
Collet for puller 001 589 36 33 00 for tapered roller bearing inner race	small center piece large center piece	 11004-7084	000 589 33 34 00 000 589 34 34 00
Installer for tapered roller bearing outer races		 11004-7063	116 589 11 61 00
Measuring plate for pinion height with bearing		 11004-11136	601 589 00 23 00
Dial gauge holder for measuring plate		 11004-10150	363 589 02 21 00
Measuring device for pinion bearing height in rear axle housing	small center piece	 11004-7066	115 589 00 21 00
	large center piece	 11004-7068	116 589 01 21 00
Measuring device for pinion bearing		 11004-7066	116 589 07 21 00
Dial gauge holder		 11004-7073	111 589 08 23 00
Adjusting gauge for adjusting pinion		 11004-7090	115 589 05 21 00
Torque measuring tool 30–600 Ncm 1/2" square		 11004-7074	001 589 49 21 00
Connection 3/4" square head to 1/2" square socket		 11004-6362	100 589 02 59 00
Removing tool for removing tapered roller bearing outer race and radial sealing ring from bearing cap	small center piece	 11004-7051	115 589 00 35 00

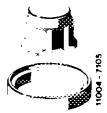
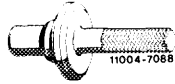
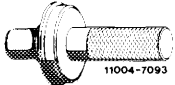
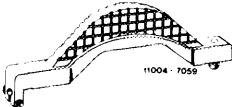
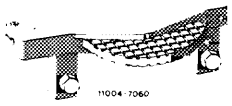
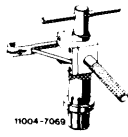
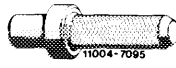
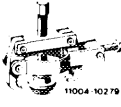
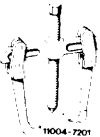
Removing tool for removing tapered roller bearing outer race from bearing cap	large center piece		116 589 00 35 00
Installing mandrel for radial sealing ring with 65 mm OD			116 589 05 43 00
Installing mandrel for radial sealing ring with 81 mm OD			116 589 10 15 00
Gauge for measuring spread by means of 2 mounting blocks	large center piece		116 589 04 21 00
	small center piece		115 589 04 21 00
Backlash gauge			115 589 03 23 00
Assembly mandrel for inner race of tapered roller bearing			115 589 04 61 00
Puller for tapered roller bearing			123 589 08 33 00
Puller for pulling gear wheel on drive pinion of vehicles with ABS			000 589 88 33 00

Conventional tools

Two-arm puller

e.g. made by Nexus, D-5630 Remscheid
order no. 100 size 2

Self-made tools

Installing sleeve for tapered roller bearing on drive pinion

A = Small drive pinion
B = Large drive pinion

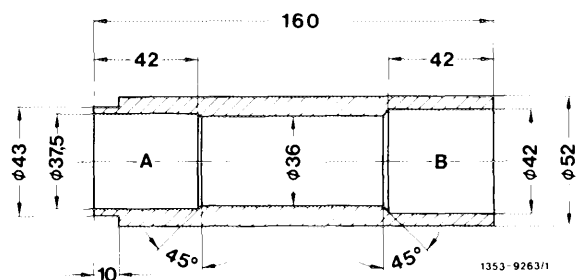

Installing sleeve for gear wheel on drive pinion of vehicles with ABS

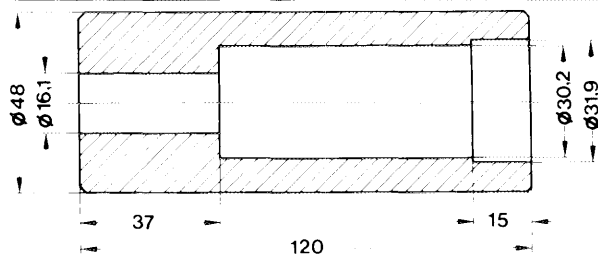

1354-9282

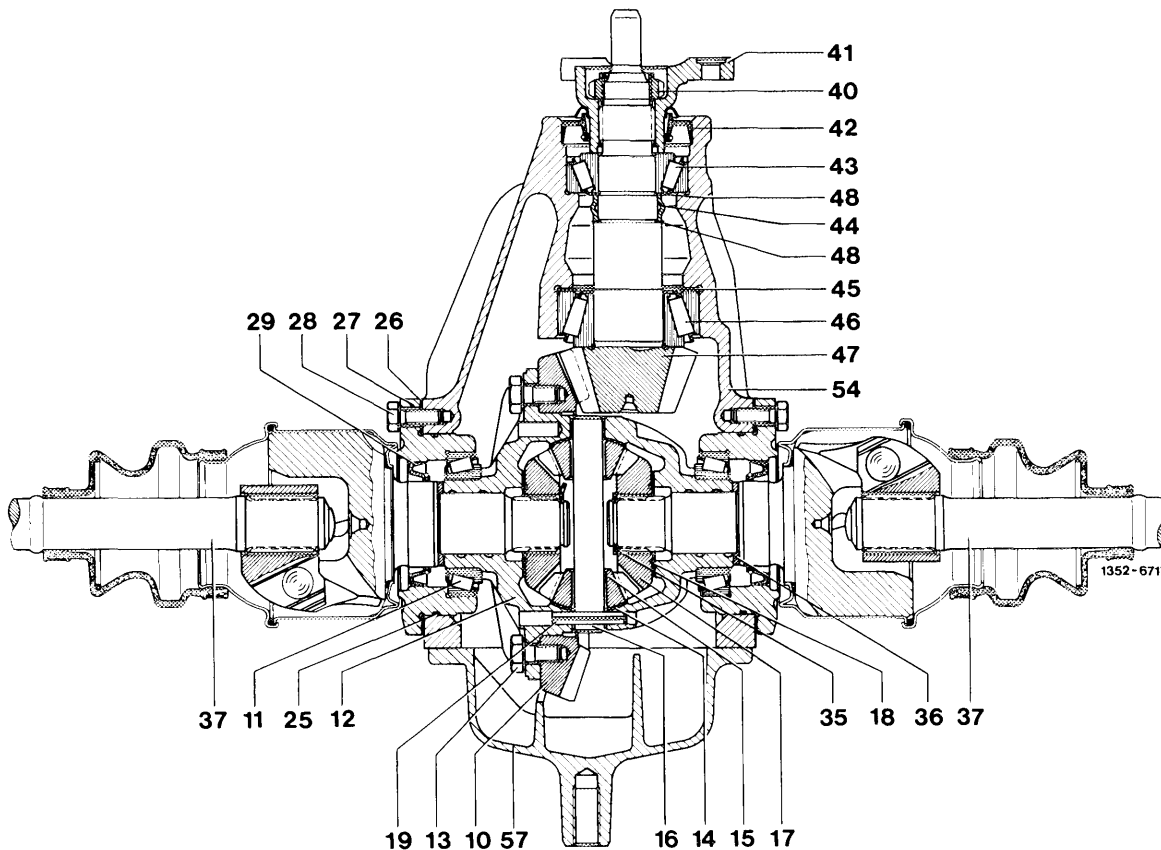

- | | | | |
|------------------------------|------------------------|---|---------------------------------|
| 10 Ring gear | 17 Side gear | 29 Radial sealing ring | 43 Small tapered roller bearing |
| 11 Tapered roller bearing | 18 Thrust washer | 35 Locking ring | 44 Spacing sleeve |
| 12 Differential housing | 19 Clamping sleeve | 36 Compensating washer | 45 Compensating washer |
| 13 Hex bolt | 25 Sealing ring | 37 Rear axle shaft complete | 46 Large tapered roller bearing |
| 14 Ball washer | 26 Compensating washer | 40 Crush collar nut or double hex. collar nut | 47 Drive pinion |
| 15 Differential pinion | 27 Bearing cap | 41 Universal flange | 48 Thrust washer |
| 16 Differential pinion shaft | 28 Hex bolt | 42 Radial sealing ring | 54 Rear axle housing |
| | | | 57 Rear axle end cover |

Disassembly

Removing differential together with ring gear

- 1 Remove rear axle center piece with rear axle shafts (35-520).
- 2 Clamp rear axle center piece with rear axle shafts on assembly stand (1) and support rear axle shafts. Drain oil from rear axle housing.

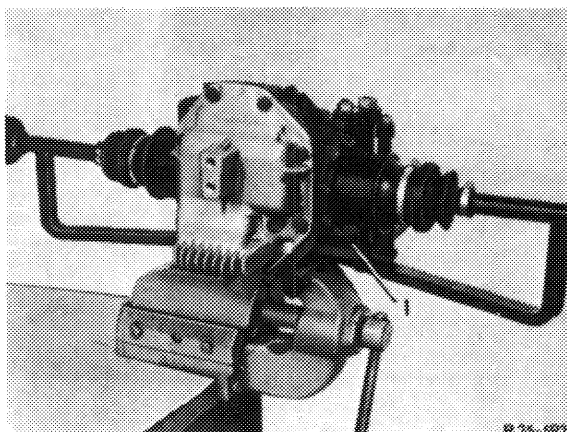

R 35-5923

3 Unscrew end cover (4) from rear axle housing.

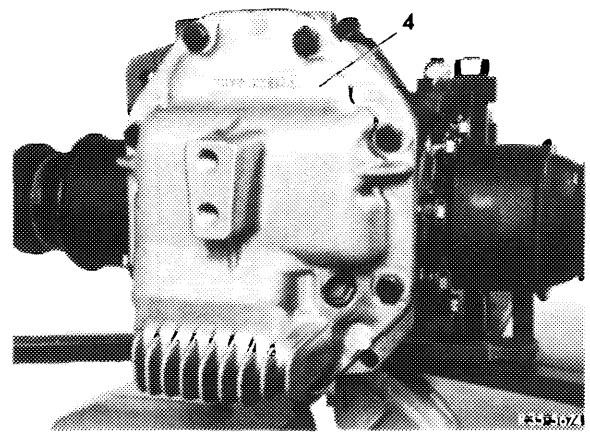

4 Pull off locking rings (26) between inner synchromesh joints and side gears by means of pliers (1) or a hook and remove from housing.

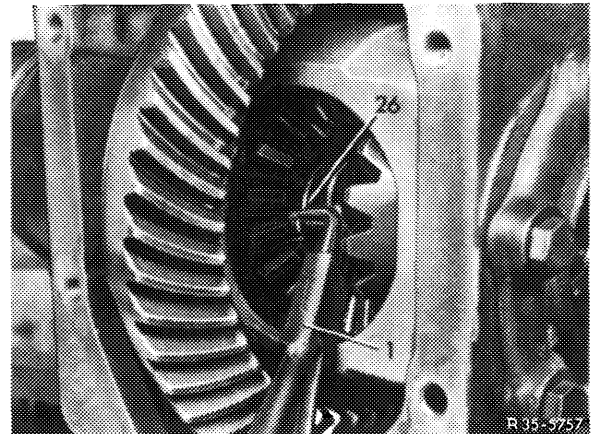

5 Pull rear axle shafts out of side gears and remove together with spacing rings (11).

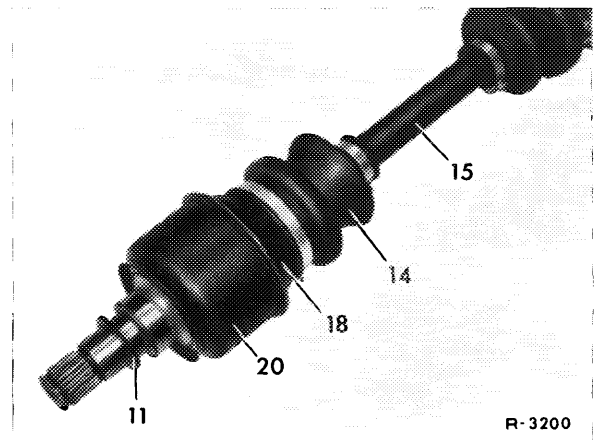

6 Remove lateral bearing caps (24).

