

35–520 Removal and installation of rear axle center piece with rear axle shafts

B. Model 107, 116

Oil types and capacities

Standard differential	Hypoid gear oil SAE 90 refer to specifications for service products page 235	
Differential with restricted slip (positive traction) (name plate on rear axle housing)	Special Hypoid gear oil refer to specifications for service products page 235.3	
Capacity	large center piece	1.3 litres
	small center piece	1.0 litre

Tightening torques

	Nm	
Hex socket bolts or hex bolts for attaching rear rubber bearing to rear axle end cover	120	
Hex bolts for attaching rear rubber bearing to frame floor	25	
Hex bolts, self-locking, for attaching rear rubber bearing to frame floor	30	
Hex bolt for attaching rear axle shaft to rear axle shaft flange	(1st version M 12)	95
	(2nd version M 8)	30
Self-locking hex. nuts for attaching rear center piece to rear axle carrier	100	
Lock nut of propeller shaft	30–40	
Threaded bushing in rear axle shaft for reduction from M 12 to M 8 (repair version)	100	
Studs on rear axle housing	50	

Special tools

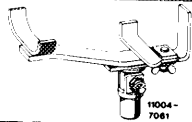
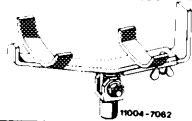
Vehicle jack top for removal and installation of rear axle center piece	small center piece		115 589 35 63 00
	large center piece		116 589 02 63 00

Assembly tool for removal and installation of rear axle shaft on rear axle shaft flange

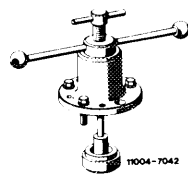

116 589 24 61 00

Torque wrench handle 25–130 Nm with plug-in ratchet 1/2" square

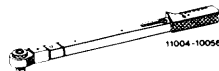

001 589 66 21 00

Torque wrench 40–200 Nm with plug-in ratchet 1/2" square

001 589 67 21 00

Open end wrench 46 mm for torque wrench for clamping nut of propeller shaft



126 589 00 01 00

Self-made tool

Tool for screwing threaded bushing into rear axle shaft

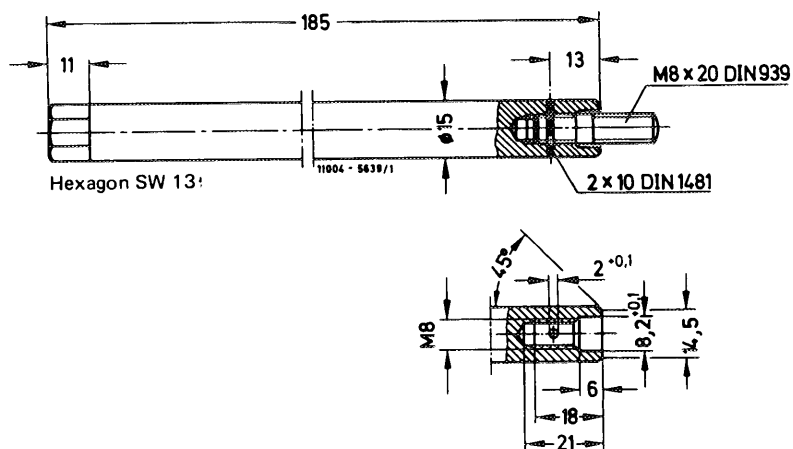

Removal

- 1 Drain oil on rear axle.
- 2 Vehicles without starting torque compensation, unscrew caliper at the right and hang up by means of a hook.

On vehicles with starting torque compensation, disconnect brake cable control, unscrew bracket on wheel carrier, remove rubber sleeve and push cover back.

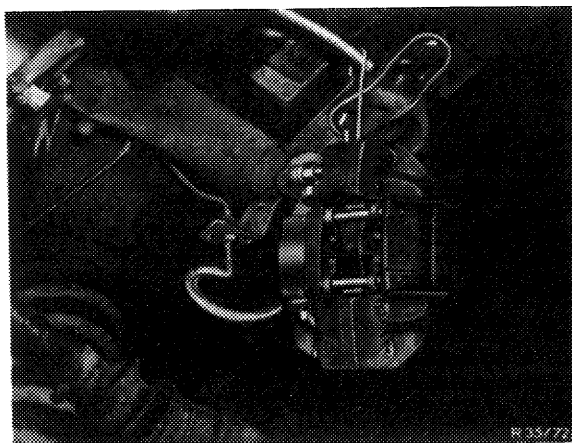

3 Loosen hex bolt (M 12) of 1st version on both sides or hex bolt (M 8) with spacing sleeve and clamping disc of 2nd version for attaching rear axle shaft to rear axle shaft flange and remove.

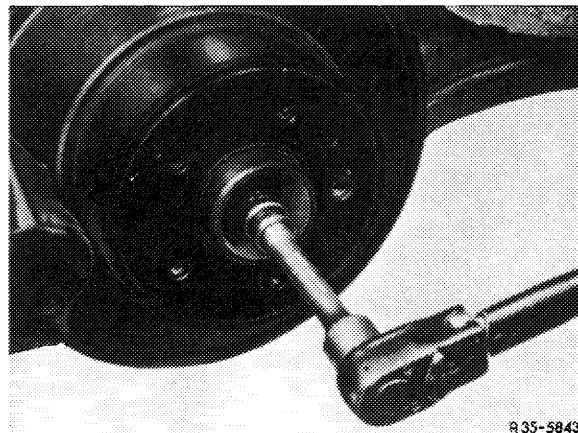

4 If required, force rear axle shaft out of rear axle shaft flange by means of assembly fixture.

Attention!

When removing assembly tool be sure to hold rear axle shaft in place. Do not let rear axle shaft drop down, since this would damage the housing of the synchromesh joint and make it leak.

If the rear axle shaft cannot be removed in spite of being fully telescoped, loosen rubber bearing from frame floor and rear center piece from rear axle carrier. Lower center piece and swivel to one side. Then remove rear axle shaft from rear axle shaft flange.

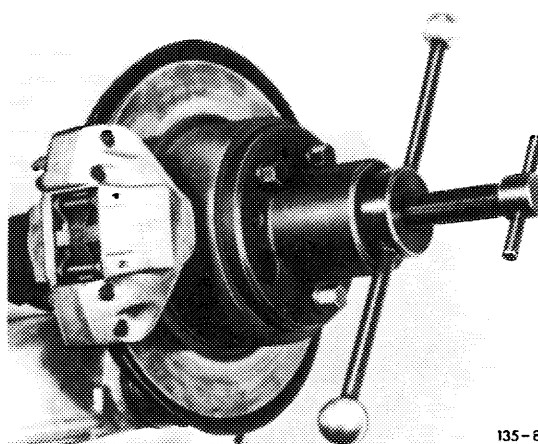

Do not loosen shock absorbers since they are required to hold axle.

5 Remove exhaust system (49-100).

6 Unscrew shielding plate.

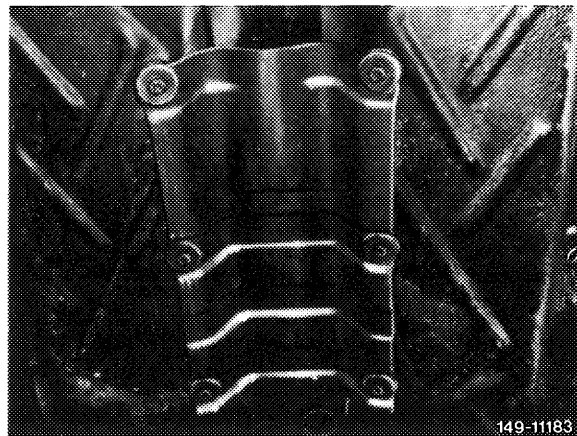

7 Loosen lock nut and unscrew propeller shaft intermediate bearing on frame floor.

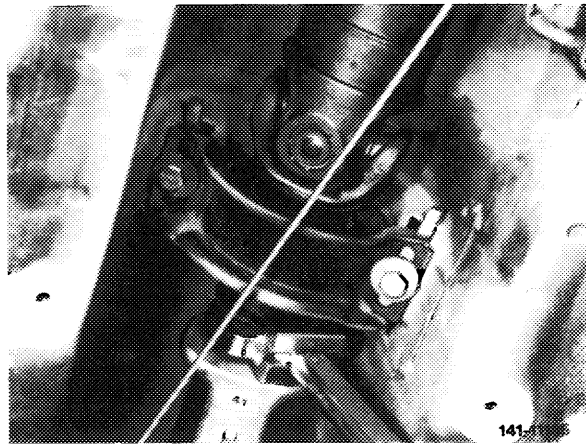

8 Unflange propeller shaft from rear axle and push forward out of concentric alignment.

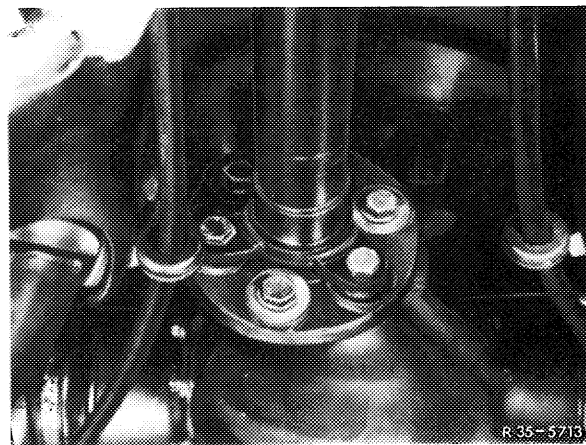

9 Vehicle with ABS

a Loosen hex. socket screw (35) and remove rpm sensor (34) from rear axle housing.

Attention!
Protect rpm sensor against damage. Do not put cable under tensile stress.

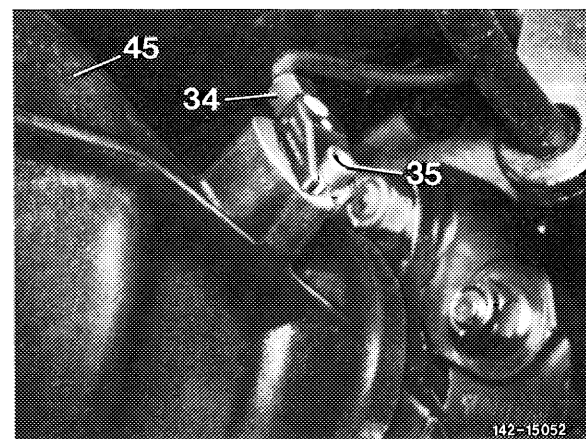

10 Support rear axle housing with a vehicle jack or a pitlift and top.

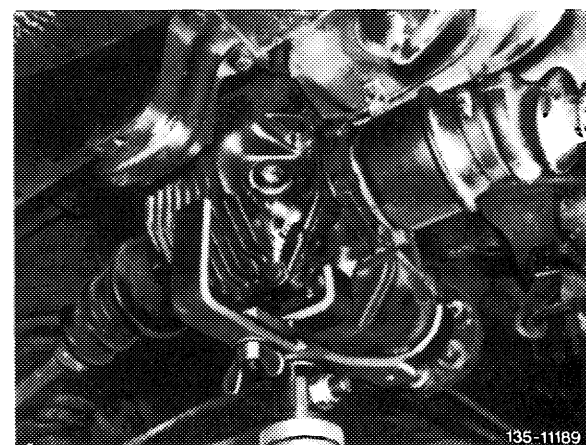

11 Unscrew rear rubber bearing on frame floor.

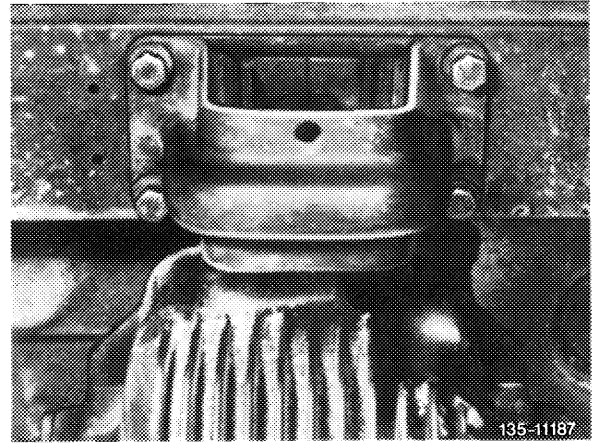

12 Lower vehicle jack or pitlift until self-locking hex nuts are accessible. Loosen brake cable control attachment at the left on frame floor (model 116).

13 Unscrew rear axle center piece from rear axle carrier (arrow).

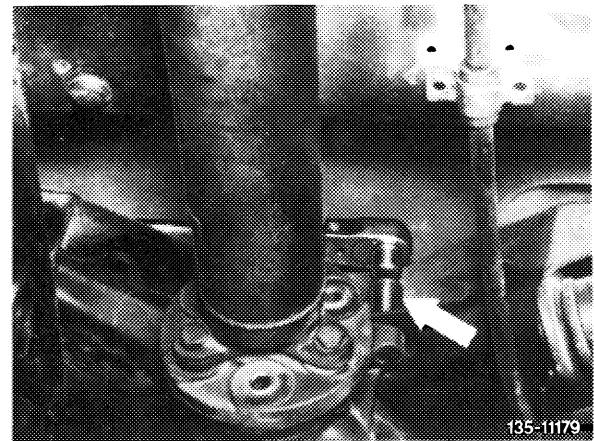

14 Lower rear axle center piece and remove together with rear axle shafts.

Attention!

When transporting rear axle center piece with rear axle shafts make sure, that the **rear axle shafts are not falling down**, since this would result in damage and leaks to the housings of the both inner synchromesh joints.

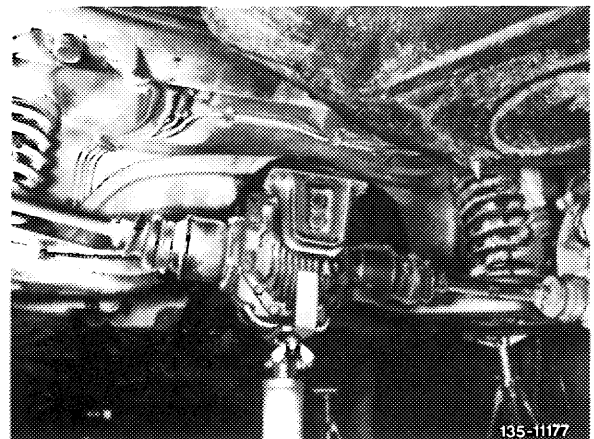

15 Unscrew rubber bearing from rear axle center piece.

16 Check rubber bearing and renew, if required.

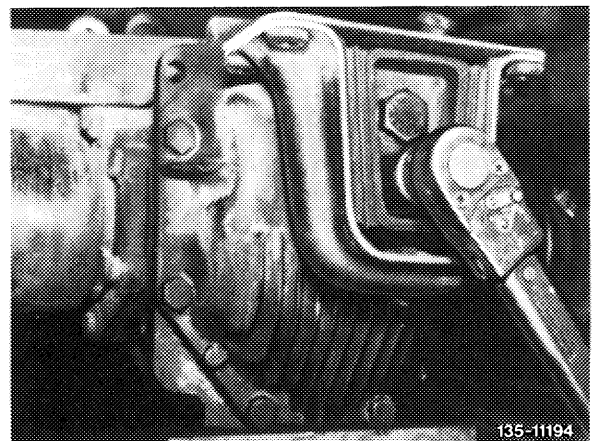

Installation

17 Attach rubber bearing to rear axle center piece. Tighten hex bolts or hex socket bolts to 120 Nm.

18 Place rear axle center piece with rear axle shafts on vehicle jack top and move into installation position.

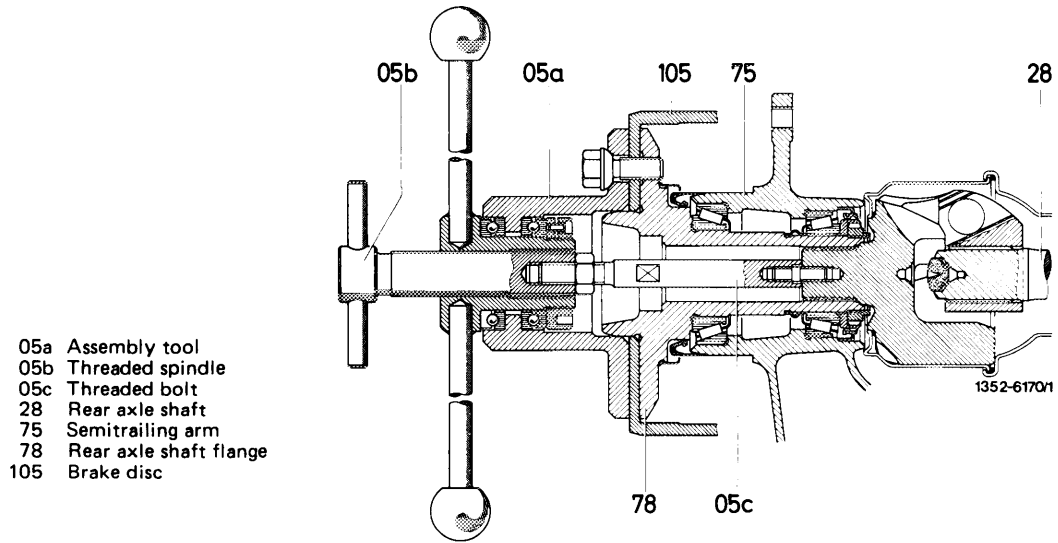
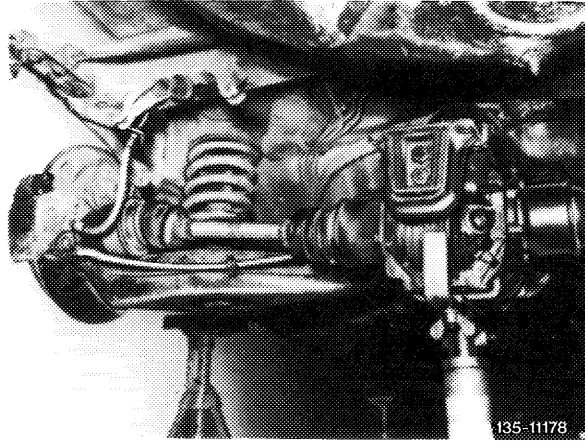

19 Introduce rear axle shafts into rear axle shaft flange by means of assembly fixture. Remove assembly fixture.

20 Lift rear axle center piece and attach to rear axle carrier. Prior to positioning self-locking hex. nuts, mount washer. Tighten self-locking nuts to 100 Nm.

Attention!

Be sure to replace self-locking nuts.

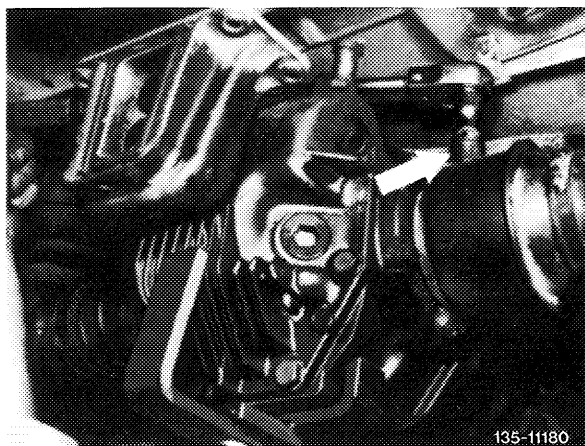

21a Tighten hex. screw for fastening rear axle shaft to rear axle shaft flange on 1st version (M 12 item 79) to 95 Nm.

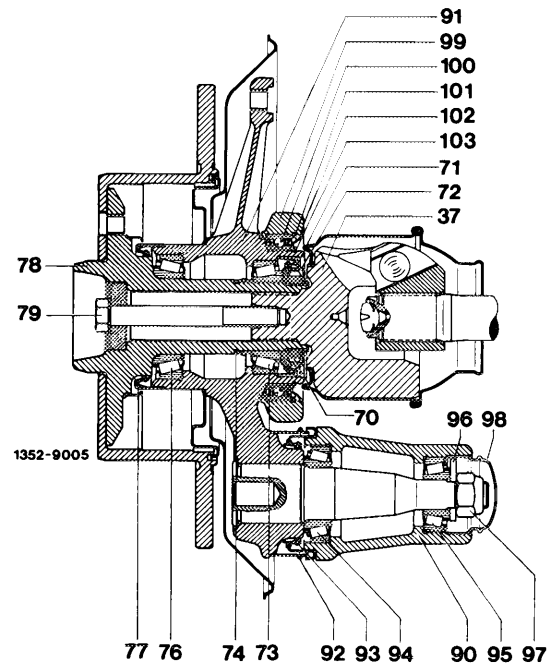

1st version
79 Hex. screw M 12 x 90

Repair solution

Attention!

Renew clamping disc (79a) after one-time use. Provide clamping disc with oil in range of screw head. Pay attention to correct length of spacing sleeve and hex. screw (refer to 35–110 or item 21b).

Note: In the event of complaints concerning clicking noises exchange hex bolt M 12 with thick washer for a hex bolt M 8 with pertinent spacing sleeve and clamping disc. For this purpose, screw a threaded bushing into rear axle shaft by means of self-made tool to reduce the threads (detail at the left). Tightening torque of threaded bushing 30 Nm.

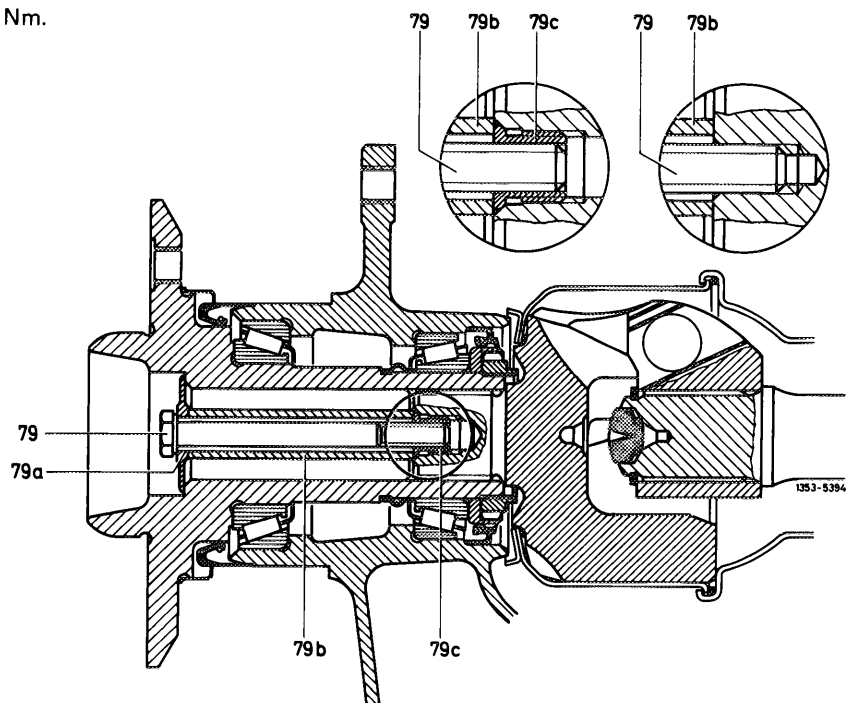

79 Hex bolt
79a Clamping disc
79b Spacing sleeve
79c Threaded bushing

Detail left:
repair solution

Detail right:
standard version

21b Mount hex. screw M 8 for attaching rear axle shaft to rear axle shaft flange on 2nd and 3rd version with clamping disc and spacing sleeve and tighten to 30 Nm.

Attention!

Renew clamping disc after one-time use. Provide clamping disc (79a) with oil in range of screw head.

2nd version

- 79 Hex. screw M 8 x 90
- 79a Clamping disc
- 79b Spacing sleeve (72.5 mm long)

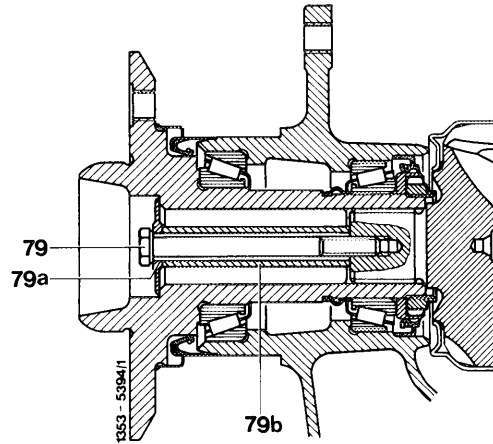

Note: Starting September 1979 the inner contour (arrow) of rear axle shaft flange has been changed and the contact surface of the tensioning disc has been displaced further inwards by 5 mm. To guarantee the correct coordination of hex. screw and spacing sleeve, measure distance "a" on rear axle flange from face to contact surface of clamping disc by means of a depth gauge and take the lengths for spacing sleeve and hex. screw from table.

Be sure to avoid wrong combination!

3rd version

- 79 Hex. screw M 8 x 85
- 79a Clamping disc
- 79b Spacing sleeve (67.5 mm long)
- a = 37 mm

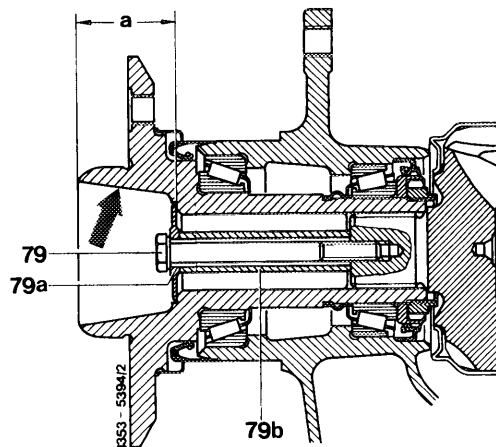

2nd rear axle shaft flange version

a = 32 mm

- Pertinent hex. screw = M 8 x 90
- Pertinent spacing sleeve = 72.5 mm

3rd rear axle shaft flange version

a = 37 mm

- Pertinent hex. screw = M 8 x 85
- Pertinent spacing sleeve = 67.5 mm

As additional external identification marks the shorter hex. screw is provided with a recess on hex. head, the surface of the shorter spacing sleeve is bright, while surface of former spacing sleeve is phosphated (bond-erized).

22 Lift rear axle center piece up to frame floor and attach rubber bearing to frame floor. Tightening torque of hex bolts 25 Nm. Tightening torque of self-locking hex bolts 30 Nm.

Attention!

Use self-locking hex bolts only once.

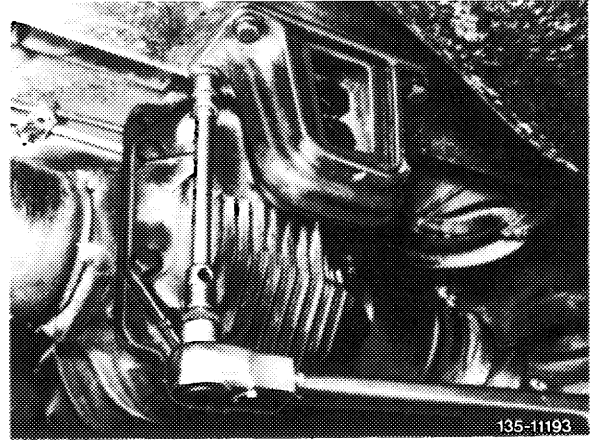

23 Attach propeller shaft to flange.

24 Attach propeller shaft intermediate bearing, but do not yet tighten.

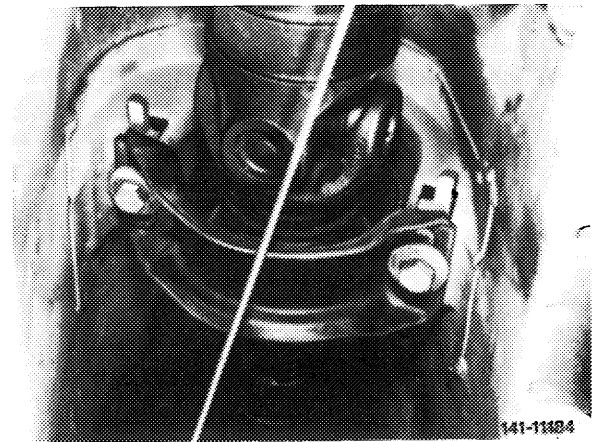

25 Vehicles with ABS

Note: Prior to installation, make sure that no metallic foreign particles are located on magnetic edge of rpm sensor.

a Replace O-ring (36) on rpm sensor (34).

- 34 Rpm sensor
- 35 Hex. socket screw
- 36 O-ring
- 43 Gear wheel (rotor)
- 44 Drive pinion
- 45 Rear axle housing

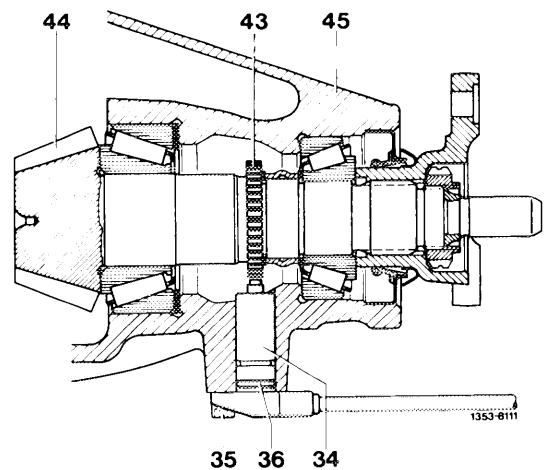

b Insert rpm sensor (34) into rear axle housing (45), making sure that the O-ring is not damaged.

Note: Use self-locking hex. socket screw only once.

c Attach rpm sensor to rear axle housing by means of hex. socket screw (35).

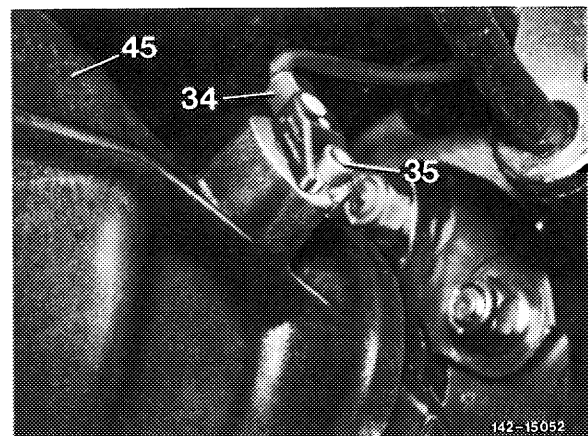

26 On rear axles without starting torque compensation, mount caliper (1) with new locking plate or self-locking hex bolts and tighten to 90 Nm (9 kpm).

On rear axles with starting torque compensation, mount bracket for brake cable control to wheel carrier. Slip on cover and rubber sleeve. Attach cable control and adjust parking brake (42–525).

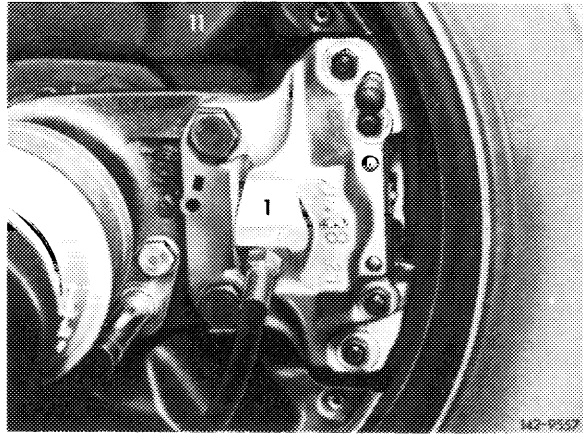

27 Fill oil into rear axle at filler hole up to overflow.

28 Tighten lock nut on propeller shaft to 30–40 Nm.

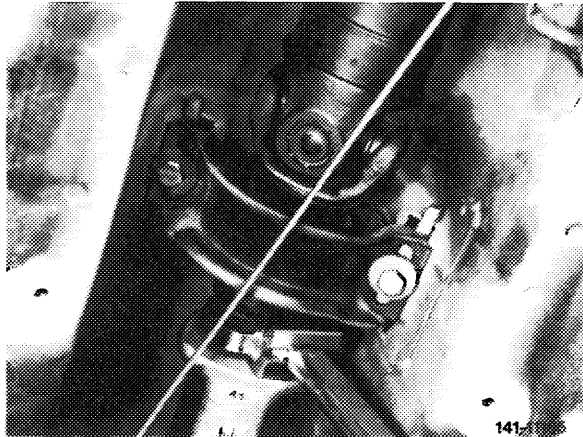

29 Tighten propeller shaft intermediate bearing.

30 Mount shielding plate.

31 Install exhaust system (49–100).

